

STATE OF NORTH CAROLINA
DEPARTMENT OF TRANSPORTATION
RALEIGH, N.C.

C204941

CONTRACT AND
CONTRACT BONDS
FOR CONTRACT NO. C204941

WBS 54035.3.1 STATE FUNDED

T.I.P NO. U-5757

COUNTY OF DAVIDSON

THIS IS THE ROADWAY CONTRACT

ROUTE NUMBER NC-8 LENGTH 0.771 MILES

LOCATION NC-8 (WINSTON RD) FROM US-29/US-70 TO SR-1846 (ARRINGTON DR).

CONTRACTOR KEMP SIGMON CONSTRUCTION CO INC

ADDRESS P.O. BOX 1270

CLAREMONT, NC 28610

BIDS OPENED SEPTEMBER 17, 2024

CONTRACT EXECUTION 10/17/2024

STATE OF NORTH CAROLINA
DEPARTMENT OF TRANSPORTATION
RALEIGH, N.C.

PROPOSAL

DATE AND TIME OF BID OPENING: **Sep 17, 2024 AT 02:00 PM**

CONTRACT ID C204941
WBS 54035.3.1

FEDERAL-AID NO. STATE FUNDED
COUNTY DAVIDSON
T.I.P NO. U-5757
MILES 0.771
ROUTE NO. NC-8
LOCATION NC-8 (WINSTON RD) FROM US-29/US-70 TO SR-1846 (ARRINGTON DR).

TYPE OF WORK GRADING, DRAINAGE, PAVING, AND SIGNALS.

NOTICE:

ALL BIDDERS SHALL COMPLY WITH ALL APPLICABLE LAWS REGULATING THE PRACTICE OF GENERAL CONTRACTING AS CONTAINED IN CHAPTER 87 OF THE GENERAL STATUTES OF NORTH CAROLINA WHICH REQUIRES THE BIDDER TO BE LICENSED BY THE N.C. LICENSING BOARD FOR CONTRACTORS WHEN BIDDING ON ANY NON-FEDERAL AID PROJECT WHERE THE BID IS \$30,000 OR MORE, EXCEPT FOR CERTAIN SPECIALTY WORK AS DETERMINED BY THE LICENSING BOARD. BIDDERS SHALL ALSO COMPLY WITH ALL OTHER APPLICABLE LAWS REGULATING THE PRACTICES OF ELECTRICAL, PLUMBING, HEATING AND AIR CONDITIONING AND REFRIGERATION CONTRACTING AS CONTAINED IN CHAPTER 87 OF THE GENERAL STATUTES OF NORTH CAROLINA. NOTWITHSTANDING THESE LIMITATIONS ON BIDDING, THE BIDDER WHO IS AWARDED ANY FEDERAL - AID FUNDED PROJECT SHALL COMPLY WITH CHAPTER 87 OF THE GENERAL STATUTES OF NORTH CAROLINA FOR LICENSING REQUIREMENTS WITHIN 60 CALENDAR DAYS OF BID OPENING.

BIDS WILL BE RECEIVED AS SHOWN BELOW:

THIS IS A ROADWAY PROPOSAL

5% BID BOND OR BID DEPOSIT REQUIRED

**PROPOSAL FOR THE CONSTRUCTION OF
CONTRACT No. C204941 IN DAVIDSON COUNTY, NORTH CAROLINA
DEPARTMENT OF TRANSPORTATION,
RALEIGH, NORTH CAROLINA**

The Bidder has carefully examined the location of the proposed work to be known as Contract No. **C204941** has carefully examined the plans and specifications, which are acknowledged to be part of the proposal, the special provisions, the proposal, the form of contract, and the forms of contract payment bond and contract performance bond; and thoroughly understands the stipulations, requirements and provisions. The undersigned bidder agrees to bound upon his execution of the bid and subsequent award to him by the Board of Transportation in accordance with this proposal to provide the necessary contract payment bond and contract performance bond within fourteen days after the written notice of award is received by him. The undersigned Bidder further agrees to provide all necessary machinery, tools, labor, and other means of construction; and to do all the work and to furnish all materials, except as otherwise noted, necessary to perform and complete the said contract in accordance with the *2024 Standard Specifications for Roads and Structures* by the dates(s) specified in the Project Special Provisions and in accordance with the requirements of the Engineer, and at the unit or lump sum prices, as the case may be, for the various items given on the sheets contained herein.

The Bidder shall provide and furnish all the materials, machinery, implements, appliances and tools, and perform the work and required labor to construct and complete Contract No. **C204941** in **Davidson County**, for the unit or lump sum prices, as the case may be, bid by the Bidder in his bid and according to the proposal, plans, and specifications prepared by said Department, which proposal, plans, and specifications show the details covering this project, and hereby become a part of this contract.

The published volume entitled *North Carolina Department of Transportation, Raleigh, Standard Specifications for Roads and Structures, January 2024* with all amendments and supplements thereto, is by reference incorporated into and made a part of this contract; that, except as herein modified, all the construction and work included in this contract is to be done in accordance with the specifications contained in said volume, and amendments and supplements thereto, under the direction of the Engineer.

If the proposal is accepted and the award is made, the contract is valid only when signed either by the Contract Officer or such other person as may be designated by the Secretary to sign for the Department of Transportation. The conditions and provisions herein cannot be changed except over the signature of the said Contract Officer.

The quantities shown in the itemized proposal for the project are considered to be approximate only and are given as the basis for comparison of bids. The Department of Transportation may increase or decrease the quantity of any item or portion of the work as may be deemed necessary or expedient.

An increase or decrease in the quantity of an item will not be regarded as sufficient ground for an increase or decrease in the unit prices, nor in the time allowed for the completion of the work, except as provided for the contract.

Accompanying this bid is a bid bond secured by a corporate surety, or certified check payable to the order of the Department of Transportation, for five percent of the total bid price, which deposit is to be forfeited as liquidated damages in case this bid is accepted and the Bidder shall fail to provide the required payment and performance bonds with the Department of Transportation, under the condition of this proposal, within 14 calendar days after the written notice of award is received by him, as provided in the *Standard Specifications*; otherwise said deposit will be returned to the Bidder.



State Contract Officer

Signed by:

Ronald Elton Davenport, Jr.

5AE54B6DC24B4A9...

08/14/2024

TABLE OF CONTENTS

**COVER SHEET
PROPOSAL SHEET**

PROJECT SPECIAL PROVISIONS

HAUL ROADS:..... G-1
CONTRACT TIME AND LIQUIDATED DAMAGES: G-1
INTERMEDIATE CONTRACT TIME NUMBER 1 AND LIQUIDATED DAMAGES: G-1
INTERMEDIATE CONTRACT TIME NUMBER 2 AND LIQUIDATED DAMAGES: G-2
INTERMEDIATE CONTRACT TIME NUMBER 3 AND LIQUIDATED DAMAGES: G-3
PERMANENT VEGETATION ESTABLISHMENT:..... G-4
DELAY IN RIGHT OF ENTRY:..... G-4
MAJOR CONTRACT ITEMS: G-5
SPECIALTY ITEMS:..... G-5
FUEL PRICE ADJUSTMENT:..... G-5
STEEL PRICE ADJUSTMENT:..... G-7
SCHEDULE OF ESTIMATED COMPLETION PROGRESS:..... G-18
MINORITY BUSINESS ENTERPRISE AND WOMEN BUSINESS ENTERPRISE:..... G-18
RESTRICTIONS ON ITS EQUIPMENT AND SERVICES:..... G-35
USE OF UNMANNED AIRCRAFT SYSTEM (UAS): G-35
EQUIPMENT IDLING GUIDELINES:..... G-35
SUBSURFACE INFORMATION:..... G-36
MAINTENANCE OF THE PROJECT: G-36
COOPERATION BETWEEN CONTRACTORS:..... G-37
TWELVE MONTH GUARANTEE:..... G-37
OUTSOURCING OUTSIDE THE USA:..... G-38
EROSION AND SEDIMENT CONTROL/STORMWATER CERTIFICATION: G-38
PROCEDURE FOR MONITORING BORROW PIT DISCHARGE:..... G-43
NOTE TO CONTRACTOR G-45

ROADWAYR-1

STANDARD SPECIAL PROVISIONS

AVAILABILITY OF FUNDS – TERMINATION OF CONTRACTSSSP-1
NCDOT GENERAL SEED SPECIFICATION FOR SEED QUALITYSSP-2
ERRATA.....SSP-5
PLANT AND PEST QUARANTINESSSP-6
MINIMUM WAGESSSP-7
TITLE VI AND NONDISCRIMINATION:SSP-8
ON-THE-JOB TRAINING.....SSP-17

UNIT PROJECT SPECIAL PROVISIONS

GEOENVIRONMENTAL..... GV-1
TRAFFIC CONTROL TC-1
UTILITY CONSTRUCTION.....UC-1
UTILITY BY OTHERS.....UBO-1
EROSION CONTROL EC-1
TRAFFIC SIGNALSTS-1

PROPOSAL ITEM SHEET

ITEM SHEET(S)

PROJECT SPECIAL PROVISIONS**GENERAL****HAUL ROADS:**

(7-16-24)

105

SP1 G04

Revise the *Standard Specifications* as follows:

Page 1-45, Article 105-15 RESTRICTION OF LOAD LIMITS, line 31, add the following after second sentence of the second paragraph:

At least 30 days prior to use, the Contractor shall notify the Engineer of any public road proposed for use as a haul road for the project.

CONTRACT TIME AND LIQUIDATED DAMAGES:

(8-15-00) (Rev. 5-16-23)

108

SP1 G08 A

The date of availability for this contract is **October 28, 2024**, except that work in jurisdictional waters and wetlands shall not begin until a meeting between the DOT, Regulatory Agencies, and the Contractor is held as stipulated in the permits contained elsewhere in this proposal. This delay in availability has been considered in determining the contract time for this project.

The completion date for this contract is **May 14, 2027**.

Except where otherwise provided by the contract, observation periods required by the contract will not be a part of the work to be completed by the completion date and/or intermediate contract times stated in the contract. The acceptable completion of the observation periods that extend beyond the final completion date shall be a part of the work covered by the performance and payment bonds.

The liquidated damages for this contract are **Two Hundred Dollars (\$ 200.00)** per calendar day. These liquidated damages will not be cumulative with any liquidated damages which may become chargeable under Intermediate Contract Time Number 1.

INTERMEDIATE CONTRACT TIME NUMBER 1 AND LIQUIDATED DAMAGES:

(7-1-95) (Rev. 2-21-12)

108

SP1 G13 A

Except for that work required under the Project Special Provisions entitled *Planting, Reforestation* and/or *Permanent Vegetation Establishment*, included elsewhere in this proposal, the Contractor will be required to complete all work included in this contract and shall place and maintain traffic on same.

The date of availability for this intermediate contract time is **October 28, 2024**.

The completion date for this intermediate contract time is **November 15, 2026**.

The liquidated damages for this intermediate contract time are **Two Thousand Dollars (\$ 2,000.00)** per calendar day.

Upon apparent completion of all the work required to be completed by this intermediate date, a final inspection will be held in accordance with Article 105-17 and upon acceptance, the Department will assume responsibility for the maintenance of all work except *Planting, Reforestation* and/or *Permanent Vegetation Establishment*. The Contractor will be responsible for and shall make corrections of all damages to the completed roadway caused by his planting operations, whether occurring prior to or after placing traffic through the project.

INTERMEDIATE CONTRACT TIME NUMBER 2 AND LIQUIDATED DAMAGES:

(2-20-07)

108

SP1 G14 A

The Contractor shall complete the required work of installing, maintaining, and removing the traffic control devices for lane closures and restoring traffic to the existing traffic pattern. The Contractor shall not close or narrow a lane of traffic on **NC 8 (Winston Road)** during the following time restrictions:

DAY AND TIME RESTRICTIONS

Monday thru Friday, 7:00 A.M. to 9:00 A.M. and 4:00 P.M. to 7:00 P.M.

In addition, the Contractor shall not close or narrow a lane of traffic on **NC 8 (Winston Road)**, detain and/or alter the traffic flow on or during holidays, holiday weekends, special events, or any other time when traffic is unusually heavy, including the following schedules:

HOLIDAY AND HOLIDAY WEEKEND LANE CLOSURE RESTRICTIONS

1. For **unexpected occurrence** that creates unusually high traffic volumes, as directed by the Engineer.
2. For **New Year's Day**, between the hours of **7:00 A.M.** December 31st and **7:00 P.M.** January 2nd. If New Year's Day is on a Friday, Saturday, Sunday or Monday, then until **7:00 P.M.** the following Tuesday.
3. For **Easter**, between the hours of **7:00 A.M.** Thursday and **7:00 P.M.** Monday.
4. For **Memorial Day**, between the hours of **7:00 A.M.** Friday and **7:00 P.M.** Tuesday.
5. For **Independence Day**, between the hours of **7:00 A.M.** the day before Independence Day and **7:00 P.M.** the day after Independence Day.

If **Independence Day** is on a Friday, Saturday, Sunday or Monday, then between the hours of **7:00 A.M.** the Thursday before Independence Day and **7:00 P.M.** the Tuesday after Independence Day.

6. For **Labor Day**, between the hours of **7:00 A.M.** Friday and **7:00 P.M.** Tuesday.
7. For **Thanksgiving**, between the hours of **7:00 A.M.** Tuesday and **7:00 P.M.** Monday.

8. For **Christmas**, between the hours of **7:00 A.M.** the Friday before the week of Christmas Day and **7:00 P.M.** the following Tuesday after the week of Christmas Day.

Holidays and holiday weekends shall include New Year's, Easter, Memorial Day, Independence Day, Labor Day, Thanksgiving, and Christmas. The Contractor shall schedule his work so that lane closures will not be required during these periods, unless otherwise directed by the Engineer.

The time of availability for this intermediate contract work shall be the time the Contractor begins to install all traffic control devices for lane closures according to the time restrictions listed herein.

The completion time for this intermediate contract work shall be the time the Contractor is required to complete the removal of all traffic control devices for lane closures according to the time restrictions stated above and place traffic in the existing traffic pattern.

The liquidated damages are **Two Hundred Fifty Dollars (\$ 250.00)** per fifteen (15) minute time period.

INTERMEDIATE CONTRACT TIME NUMBER 3 AND LIQUIDATED DAMAGES:

(2-20-07) (Rev. 6-18-13)

108

SPI G14 G

The Contractor shall complete the work required of **Phase I, Step #3** as shown on Sheet **TMP-3** and shall place and maintain traffic on same.

The time of availability for this intermediate contract time is the time the Contractor begins the work.

The completion time for this intermediate contract time is the time which is **seventy-two (72)** consecutive hours after the Contractor begins this work.

The liquidated damages are **Two Hundred Fifty Dollars (\$ 250.00)** per fifteen (15) minute time period.

PERMANENT VEGETATION ESTABLISHMENT:

(2-16-12)(Rev. 1-16-24)

104

SP1 G16

Establish a permanent stand of the vegetation mixture shown in the contract. During the period between initial vegetation planting and final project acceptance, perform all work necessary to establish permanent vegetation on all erodible areas within the project limits, as well as, in borrow and waste pits. This work shall include erosion control device maintenance and installation, repair seeding and mulching, supplemental seeding and mulching, mowing, and fertilizer topdressing, as directed. All work shall be performed in accordance with the applicable section of the *Standard Specifications*. All work required for initial vegetation planting shall be performed as a part of the work necessary for the completion and acceptance of the Intermediate Contract Time (ICT). Between the time of ICT and Final Project acceptance, or otherwise referred to as the vegetation establishment period, the Department will be responsible for preparing the required National Pollutant Discharge Elimination System (NPDES) inspection records.

Once the Engineer has determined that the permanent vegetation establishment requirement has been achieved at an 80% vegetation density (the amount of established vegetation per given area to stabilize the soil) and no erodible areas exist within the project limits, the Contractor will be notified to remove the remaining erosion control devices that are no longer needed. The Contractor will be responsible for, and shall correct any areas disturbed by operations performed in permanent vegetation establishment and the removal of temporary erosion control measures, whether occurring prior to or after placing traffic on the project.

Payment for *Response for Erosion Control, Seeding and Mulching, Repair Seeding, Supplemental Seeding, Mowing, Fertilizer Topdressing, Silt Excavation, and Stone for Erosion Control* will be made at contract unit prices for the affected items. Work required that is not represented by contract line items will be paid in accordance with Articles 104-7 or 104-3 of the *Standard Specifications*. No additional compensation will be made for maintenance and removal of temporary erosion control items.

DELAY IN RIGHT OF ENTRY:

(7-1-95) (Rev. 7-15-14)

108

SP1 G22

The Contractor will not be allowed right of entry to the following parcel(s) prior to the listed date(s) unless otherwise permitted by the Engineer.

| <u>Parcel No.</u> | <u>Property Owner</u> | <u>Date</u> |
|--------------------------|------------------------------|--------------------|
| 7 | Hayes Jewelers | 3-01-2025 |

MAJOR CONTRACT ITEMS:

(2-19-02)(Rev. 1-16-24)

104

SP1 G28

The following listed items are the major contract items for this contract (see Article 104-5 of the *Standard Specifications*):

| Line # | Description |
|---------------|---|
| 40 | Asphalt Conc Base Course, Type B25.0C |
| 41 | Asphalt Conc Intermediate Course, Type I19.0C |
| 42 | Asphalt Conc Surface Course, Type S9.5C |
| 107 | 6" Water Line |

SPECIALTY ITEMS:

(7-1-95)(Rev. 1-16-24)

108-6

SP1 G37

Items listed below will be the specialty items for this contract (see Article 108-6 of the *Standard Specifications*).

| Line # | Description |
|---------------|-----------------------------|
| 74-76 | Fencing |
| 80-84 | Signing |
| 98-101 | Long-Life Pavement Markings |
| 107-127 | Utility Construction |
| 128-154 | Erosion Control |
| 155-197 | Signals/ITS System |

FUEL PRICE ADJUSTMENT:

(11-15-05)(Rev. 1-16-24)

109-8

SP1 G43

Page 1-82, Article 109-8, FUEL PRICE ADJUSTMENTS, add the following:

The base index price for DIESEL #2 FUEL is \$ **2.5238** per gallon. Where any of the following are included as pay items in the contract, they will be eligible for fuel price adjustment.

The pay items and the fuel factor used in calculating adjustments to be made will be as follows:

| Description | Units | Fuel Usage Factor Diesel |
|---|---------|--------------------------|
| Unclassified Excavation | Gal/CY | 0.29 |
| Borrow Excavation | Gal/CY | 0.29 |
| Class IV Subgrade Stabilization | Gal/Ton | 0.55 |
| Aggregate Base Course | Gal/Ton | 0.55 |
| Sub-Ballast | Gal/Ton | 0.55 |
| Erosion Control Stone | Gal/Ton | 0.55 |
| Rip Rap, Class _____ | Gal/Ton | 0.55 |
| Asphalt Concrete Base Course, Type _____ | Gal/Ton | 0.90 or 2.90 |
| Asphalt Concrete Intermediate Course, Type _____ | Gal/Ton | 0.90 or 2.90 |
| Asphalt Concrete Surface Course, Type _____ | Gal/Ton | 0.90 or 2.90 |
| Open-Graded Asphalt Friction Course | Gal/Ton | 0.90 or 2.90 |
| Permeable Asphalt Drainage Course, Type _____ | Gal/Ton | 0.90 or 2.90 |
| Sand Asphalt Surface Course, Type _____ | Gal/Ton | 0.90 or 2.90 |
| Ultra-thin Bonded Wearing Course | Gal/Ton | 0.90 or 2.90 |
| Aggregate for Cement Treated Base Course | Gal/Ton | 0.55 |
| Portland Cement for Cement Treated Base Course | Gal/Ton | 0.55 |
| > 11" Portland Cement Concrete Pavement | Gal/SY | 0.327 |
| Concrete Shoulders Adjacent to > 11" Pavement | Gal/SY | 0.327 |
| 9" to 11" Portland Cement Concrete Pavement | Gal/SY | 0.272 |
| Concrete Shoulders Adjacent to 9" to 11" Pavement | Gal/SY | 0.272 |
| < 9" Portland Cement Concrete Pavement | Gal/SY | 0.245 |
| Concrete Shoulders Adjacent to < 9" Pavement | Gal/SY | 0.245 |

For the asphalt items noted in the chart as eligible for fuel adjustments, the bidder may include the *Fuel Usage Factor Adjustment Form* with their bid submission if they elect to use the fuel usage factor. The *Fuel Usage Factor Adjustment Form* is found at the following link:

<https://connect.ncdot.gov/letting/LetCentral/Fuel%20Usage%20Factor%20Adjustment%20Form%20-%20Starting%20Nov%202022%20Lettings.pdf>

Select either 2.90 Gal/Ton fuel factor or 0.90 Gal/Ton fuel factor for each asphalt line item on the *Fuel Usage Factor Adjustment Form*. The selected fuel factor for each asphalt item will remain in effect for the duration of the contract.

Failure to complete the *Fuel Usage Factor Adjustment Form* will result in using 2.90 gallons per ton as the Fuel Usage Factor for Diesel for the asphalt items noted above. The contractor will not be permitted to change the Fuel Usage Factor after the bids are submitted.

STEEL PRICE ADJUSTMENT:

(4-19-22)(Rev. 12-20-22)

SP1 G47

Description and Purpose

Steel price adjustments will be made to the payments due the Contractor for items as defined herein that are permanently incorporated into the work, when the price of raw steel mill products utilized on the contract have fluctuated. The Department will adjust monthly progress payments up or down as appropriate for cost changes in steel according to this provision.

Eligible Items

The list of eligible bid items for steel price adjustment can be found on the Departments website at the following address:

<https://connect.ncdot.gov/letting/LetCentral/Eligible%20Bid%20Items%20for%20Steel%20Price%20Adjustment.xlsx>

Nuts, bolts, anchor bolts, rebar chairs, connecting bands and other miscellaneous hardware associated with these items shall not be included in the price adjustment.

Adjustments will only be made for fluctuations in the material cost of the steel used in the above products as specified in the Product Relationship Table below. The producing mill is defined as the source of steel product before any fabrication has occurred (e.g., coil, plate, rebar, hot rolled shapes, etc.). No adjustment will be made for changes in the cost of fabrication, coating, shipping, storage, etc.

No steel price adjustments will be made for any products manufactured from steel having an adjustment date, as defined by the Product Relationship Table below, prior to the letting date.

Bid Submittal Requirements

The successful bidder, within 14 calendar days after the notice of award is received by him, shall provide the completed Form SPA-1 to the Department (State Contract Officer or Division Contract Engineer) along with the payment bonds, performance bonds and contract execution signature sheets in a single submittal. If Form SPA-1 is not included in the same submittal as the payment bonds, performance bonds and contract execution signature sheets, the Contractor will not be eligible for any steel price adjustment for any item in the contract for the life of the contract. Form SPA-1 can be found on the Department's website at the following address:

<https://connect.ncdot.gov/letting/LetCentral/Form%20SPA-1.xlsm>

The Contractor shall provide Form SPA-1 listing the Contract Line Number, (with corresponding Item Number, Item Description, and Category) for the steel products they wish to have an adjustment calculated. Only the contract items corresponding to the list of eligible item numbers for steel price adjustment may be entered on Form SPA-1. The Contractor may choose to have steel price adjustment applied to any, all, or none of the eligible items. However, the Contractor's selection of items for steel price adjustment or non-selection (non-participation)

may not be changed once Form SPA-1 has been received by the Department. Items the Bidder chooses for steel price adjustment must be designated by writing the word “Yes” in the column titled “Option” by each Pay Item chosen for adjustment. Should the bidder elect an eligible steel price item, the entire quantity of the line item will be subject to the price adjustment for the duration of the Contract. The Bidder’s designations on Form SPA-1 must be written in ink or typed and signed by the Bidder (Prime Contractor) to be considered complete. Items not properly designated, designated with “No”, or left blank on the Bidder’s Form SPA-1 will automatically be removed from consideration for adjustment. No steel items will be eligible for steel price adjustment on this Project if the Bidder fails to return Form SPA-1 in accordance with this provision.

Establishing the Base Price

The Department will use a blend of monthly average prices as reported from the Fastmarkets platform to calculate the monthly adjustment indices (BI and MI). This data is typically available on the first day of the month for the preceding month. The indices will be calculated by the Department for the different categories found on the Product Relationship Table below. For item numbers that include multiple types of steel products, the category listed for that item number will be used for adjusting each steel component.

- The bidding index for Category 1 Steel items is **\$ 37.70** per hundredweight.
- The bidding index for Category 2 Steel items is **\$ 51.52** per hundredweight.
- The bidding index for Category 3 Steel items is **\$ 60.70** per hundredweight.
- The bidding index for Category 4 Steel items is **\$ 36.05** per hundredweight.
- The bidding index for Category 5 Steel items is **\$ 53.69** per hundredweight.
- The bidding index for Category 6 Steel items is **\$ 51.85** per hundredweight.
- The bidding index for Category 7 Steel items is **\$ 39.74** per hundredweight.

The bidding index represents a selling price of steel based on Fastmarkets data for the month of **July 2024**.

- MI = Monthly Index. – in Dollars (\$) per hundredweight (CWT). Use the adjustment indices from the month the steel was shipped from the producing mill, received on the project, or member cast as defined in the Product Relationship Table.
- BI = Bidding Index. - in Dollars (\$) per hundredweight (CWT). Use the adjustment indices as listed in the proposal.

| <i>Product Relationship Table</i> | | | |
|---|--|-----------------------------------|----------|
| <i>Steel Product (Title)</i> | BI, MI* | Adjustment Date for MI | Category |
| Reinforcing Steel, Bridge Deck, and SIP Forms | Based on one or more Fastmarkets indices | Delivery Date from Producing Mill | 1 |
| Structural Steel and Encasement Pipe | Based on one or more Fastmarkets indices | Delivery Date from Producing Mill | 2 |
| Steel H-Piles, Soldier Pile Walls | Based on one or more Fastmarkets indices | Delivery Date from Producing Mill | 3 |
| Guardrail Items and Pipe | Based on one or more | Material Received Date** | 4 |

| | | | |
|--|--|--------------------------|---|
| Piles | Fastmarkets indices | | |
| Fence Items | Based on one or more Fastmarkets indices | Material Received Date** | 5 |
| Overhead Sign Assembly, Signal Poles, High Mount Standards | Based on one or more Fastmarkets indices | Material Received Date** | 6 |
| Prestressed Concrete Members | Based on one or more Fastmarkets indices | Cast Date of Member | 7 |
| * BI and MI are in converted units of Dollars per Hundredweight (\$/CWT) | | | |
| ** Material Received Date is defined as the date the materials are received on the project site. If a material prepayment is made for a Category 4-6 item, the Adjustment Date to be used will be the date of the prepayment request instead of the Materials Received Date. | | | |

Submit documentation to the Engineer for all items listed in the Contract for which the Contractor is requesting a steel price adjustment.

Submittal Requirements

The items in categories 1,2, and 3, shall be specifically stored, labeled, or tagged, recognizable by color marking, and identifiable by Project for inspection and audit verification immediately upon arrival at the fabricator.

Furnish the following documentation for all steel products to be incorporated into the work and documented on Form SPA-2, found on the Departments website at the following address:

<https://connect.ncdot.gov/projects/construction/Construction%20Forms/Form%20SPA-2.xlsx>

Submit all documentation to the Engineer prior to incorporation of the steel into the completed work. The Department will withhold progress payments for the affected contract line item if the documentation is not provided and at the discretion of the Engineer the work is allowed to proceed. Progress payments will be made upon receipt of the delinquent documentation.

Step 1 (Form SPA -2)

Utilizing Form SPA-2, submit separate documentation packages for each line item from Form SPA-1 for which the Contractor opted for a steel price adjustment. For line items with multiple components of steel, each component should be listed separately. Label each SPA-2 documentation package with a unique number as described below.

- a. Documentation package number: (Insert the contract line-item) - (Insert sequential package number beginning with "1").

Example: 412 - 1,
412 - 2,
424 - 1,
424 - 2,
424 - 3, etc.

- b. The steel product quantity in pounds

- i. The following sources should be used, in declining order of precedence, to determine the weight of steel/iron, based on the Engineers decision:
 1. Department established weights of steel/iron by contract pay item per pay unit;
 2. Approved Shop Drawings;
 3. Verified Shipping Documents;
 4. Contract Plans;
 5. Standard Drawing Sheets;
 6. Industry Standards (i.e., AISC Manual of Steel Construction, AWWA Standards, etc.); and
 7. Manufacture's data.
- ii. Any item requiring approved shop drawings shall have the weights of steel calculated and shown on the shop drawings or submitted and certified separately by the fabricator.
- c. The date the steel product, subject to adjustment, was shipped from the producing mill (Categories 1-3), received on the project (Categories 4-6), or casting date (Category 7).

Step 2 (Monthly Calculator Spreadsheet)

For each month, upon the incorporation of the steel product into the work, provide the Engineer the following:

- 1) Completed NCDOT Steel Price Adjustment Calculator Spreadsheet, summarizing all the steel submittal packages (Form SPA-2) actually incorporated into the completed work in the given month.
 - a. Contract Number
 - b. Bidding Index Reference Month
 - c. Contract Completion Date or Revised Completion Date
 - d. County, Route, and Project TIP information
 - e. Item Number
 - f. Line-Item Description
 - g. Submittal Number from Form SPA-2
 - h. Adjustment date
 - i. Pounds of Steel
- 2) An affidavit signed by the Contractor stating the documentation provided in the NCDOT Steel Price Adjustment Calculator Spreadsheet is true and accurate.

Price Adjustment Conditions

Download the Monthly Steel Adjustment Spreadsheet with the most current reference data from the Department's website each month at the following address:

<https://connect.ncdot.gov/projects/construction/Construction%20Forms/Form%20SPA-3%20NCDOT%20Steel%20Price%20Adjustment%20Calculator.xlsx>

If the monthly Fastmarkets data is not available, the data for the most recent immediately preceding month will be used as the basis for adjustment.

Price Adjustment Calculations

The price adjustment will be determined by comparing the percentage of change in index value listed in the proposal (BI) to the monthly index value (MI). (See included sample examples). Weights and date of shipment must be documented as required herein. The final price adjustment dollar value will be determined by multiplying this percentage increase or decrease in the index by the represented quantity of steel incorporated into the work, and the established bidding index (BI) subject to the limitations herein.

Price increase/decrease will be computed as follows:

$$\text{SPA} = ((\text{MI} / \text{BI}) - 1) * \text{BI} * (\text{Q} / 100)$$

Where;

SPA = Steel price adjustment in dollars

MI = Monthly Shipping Index. – in Dollars (\$) per hundredweight (CWT). Use the adjustment indices from the month the steel was shipped from the producing mill, received on the project, or member cast as defined in the Product Relationship Table.

BI = Bidding Index. - in Dollars (\$) per hundredweight (CWT). Use the adjustment indices as listed in the proposal.

Q = Quantity of steel, product, pounds actually incorporated into the work as documented by the Contractor, or Design Build Team and verified by the Engineer.

Calculations for price adjustment shall be shown separate from the monthly progress estimate and will not be included in the total cost of work for determination of progress or for extension of Contract time in accordance with Subarticle 108-10(B)(1).

Any apparent attempt to unbalance bids in favor of items subject to price adjustment may result in rejection of the bid proposal.

Adjustments will be paid or charged to the Contractor only. Any Contractor receiving an adjustment under this provision shall distribute the proper proportional part of such adjustments to the subcontractor who performed the applicable work.

Delays to the work caused by steel shortages may be justification for a Contract time extension but will not constitute grounds for claims for standby equipment, extended office overhead, or other costs associated with such delays.

If an increase in the steel material price is anticipated to exceed 50% of the original quoted price, the contractor must notify the Department within 7 days prior to purchasing the material. Upon receipt of such notification, the Department will direct the Contractor to either (1) proceed with the work or (2) suspend the work and explore the use of alternate options.

If the decrease in the steel material exceeds 50% of the original quoted price, the contractor may submit to the Department additional market index information specific to the item in question to dispute the decrease. The Department will review this information and determine if the decrease is warranted.

When the steel product adjustment date, as defined in the Product Relationship Table, is after the approved contract completion date, the steel price adjustments will be based on the lesser value of either the MI for the month of the approved contract completion date or the MI for the actual adjustment date.

If the price adjustment is based on estimated material quantities for that time, and a revision to the total material quantity is made in a subsequent or final estimate, an appropriate adjustment will be made to the price adjustment previously calculated. The adjustment will be based on the same indices used to calculate the price adjustment which is being revised. If the adjustment date of the revised material quantity cannot be determined, the adjustment for the quantity in question, will be based on the indices utilized to calculate the steel price adjustment for the last initial documentation package submission, for the steel product subject to adjustment, that was incorporated into the particular item of work, for which quantities are being finalized.

Example: Structural steel for a particular bridge was provided for in three different shipments with each having a different mill shipping date. The quantity of structural steel actually used for the bridge was calculated and a steel price adjustment was made in a progress payment. At the conclusion of the work an error was found in the plans of the final quantity of structural steel used for the bridge. The quantity to be adjusted cannot be directly related to any one of the three mill shipping dates. The steel price adjustment for the quantity in question would be calculated using the indices that were utilized to calculate the steel price adjustment for the quantity of structural steel represented by the last initial structural steel documentation package submission. The package used will be the one with the greatest sequential number.

Extra Work/Force Account:

When steel products, as specified herein, are added to the contract as extra work, in accordance with the provisions of Article 104-7 or 104-3, the Engineer will determine and specify in the supplemental agreement, the need for application of steel price adjustments on a case-by-case basis. No steel price adjustments will be made for any products manufactured from steel having an adjustment date prior to the supplemental agreement execution date. Price adjustments will be made as provided herein, except the Bidding Index will be based on the month in which the supplemental agreement pricing was executed.

For work performed on force account basis, reimbursement of actual material costs, along with the specified overhead and profit markup, will be considered to include full compensation for the current cost of steel and no steel price adjustments will be made.

Examples Form SPA-2

Steel Price Adjustment Submission Form

Contract Number C203394 Bid Reference Month January 2019

Submittal Date 8/31/2019

Contract Line Item 237

Line Item Description APPROX....LBS Structural Steel

Sequential Submittal Number 2

| Supplier | Description of material | Location information | Quantity in lbs. | Adjustment Date |
|------------------|--------------------------------|------------------------|------------------|-----------------|
| XYZ mill | Structural Steel | Structure 3, Spans A-C | 1,200,000 | May 4, 2020 |
| ABC distributing | Various channel & angle shapes | Structure 3 Spans A-C | 35,000 | July 14, 2020 |
| | | | | |
| | | | | |
| | | | | |
| | | | | |
| | | | | |
| | | | | |
| | | Total Pounds of Steel | 1,235,000 | |

- Note: Attach the following supporting documentation to this form.
- Bill of Lading to support the shipping dates
 - Supporting information for weight documentation (e.g., Pay item reference, Shop drawings, shipping documents, Standards Sheets, industry standards, or manufacturer's data)

By providing this data under my signature, I attest to the accuracy of and validity of the data on this form and certify that no deliberate misrepresentation in any manner has occurred.

Printed Name

Signature

Examples Form SPA-2
Steel Price Adjustment Submission Form

Contract Number C203394 Bid Reference Month January 2019

Submittal Date August 31, 2019

Contract Line Item 237

Line Item Description SUPPORT, OVRHD SIGN STR -DFEB – STA 36+00

Sequential Submittal Number 2

| Supplier | Description of material | Location information | Quantity in lbs. | Adjustment Date |
|------------------|--|--------------------------|------------------|-------------------|
| XYZ mill | Tubular Steel (Vertical legs) | <u>-DFEB – STA 36+00</u> | 12000 | December 11, 2021 |
| PDQ Mill | 4” Tubular steel (Horizontal legs) | <u>-DFEB – STA 36+00</u> | 5900 | December 11, 2021 |
| ABC distributing | Various channel & angle shapes (see quote) | <u>-DFEB – STA 36+00</u> | 1300 | December 11, 2021 |
| | Catwalk assembly | <u>-DFEB – STA 36+00</u> | 2000 | December 11, 2021 |
| Nucor | Flat plate | <u>-DFEB – STA 36+00</u> | 650 | December 11, 2021 |
| | | | | |
| | | | | |
| | | Total Pounds of Steel | 21,850 | |

Note: Attach the following supporting documentation to this form.

- Bill of Lading to support the shipping dates
- Supporting information for weight documentation (e.g., Pay item reference, Shop drawings, shipping documents, Standards Sheets, industry standards, or manufacturer's data)

By providing this data under my signature, I attest to the accuracy of and validity of the data on this form and certify that no deliberate misrepresentation in any manner has occurred.

Printed Name

Signature

Price Adjustment Sample Calculation (increase)

Project bid on September 17, 2019

Line Item 635 "Structural Steel" has a plan quantity of 2,717,000 lbs.

Bidding Index for Structural Steel (Category 2) in the proposal was \$36.12/CWT = BI

450,000 lbs. of Structural Steel for Structure 2 at Station 44+08.60 were shipped to fabricator from the producing mill in same month, May 2021.

Monthly Index for Structural Steel (Category 2) for May 2021 was \$64.89/CWT = MI

The Steel Price Adjustment formula is as follows:

$$\text{SPA} = ((\text{MI} / \text{BI}) - 1) * \text{BI} * (\text{Q} / 100)$$

Where; SPA = Steel price adjustment in dollars

BI = Bidding Index – in dollars (\$) per hundredweight (CWT). Use the adjustment indices as listed in the proposal.

MI = Mill Shipping Index – in dollars (\$) per hundredweight (CWT). Use the adjustment indices from the month the steel was shipped from the producing mill, received on the project, or member cast as defined in the Product Relationship Table.

Q = Quantity of steel product, in pounds (lbs.) actually incorporated into the work as documented by the Contractor, or Design Build Team and verified by the Engineer.

$$\text{BI} = \$36.12 / \text{CWT}$$

$$\text{MI} = \$64.89 / \text{CWT}$$

$$\% \text{ change} = ((\text{MI} / \text{BI}) - 1) = (\$64.89 / \$36.12 - 1) = (1.79651 - 1) = 0.79651162791$$

$$\text{Q} = 450,000 \text{ lbs.}$$

$$\text{SPA} = 0.79651162791 \times \$36.12 \times (450,000 / 100)$$

$$\text{SPA} = 0.79651162791 * \$36.12 * 4,500$$

$$\text{SPA} = \$129,465 \text{ pay adjustment to Contractor for Structural Steel (Structure 2 at Station 44+08.60)}$$

Price Adjustment Sample Calculation (decrease)

Project bid on December 18, 2018

Line Item 635 Structural Steel has a plan quantity of 2,717,000 lbs.

Bidding Index for Structural Steel (Category 2) in the proposal was \$46.72/CWT = BI

600,000 lbs. of Structural Steel for Structure 1 at Station 22+57.68 were shipped to fabricator from the producing mill in same month, August 2020.

Monthly Index for Structural Steel (Category 2) for August 2020 was \$27.03/CWT = MI

The Steel Price Adjustment formula is as follows:

$$\text{SPA} = ((\text{MI} / \text{BI}) - 1) * \text{BI} * (\text{Q} / 100)$$

Where; SPA = Steel price adjustment in dollars

BI = Bidding Index – in dollars (\$) per hundredweight (CWT). Use the adjustment indices as listed in the proposal.

MI = Mill Shipping Index – in dollars (\$) per hundredweight (CWT). Use the adjustment indices from the month the steel was shipped from the producing mill, received on the project, or member cast as defined in the Product Relationship Table.

Q = Quantity of steel product, in pounds (lbs.) actually incorporated into the work as documented by the Contractor, or Design Build Team and verified by the Engineer.

$$\text{BI} = \$46.72 / \text{CWT}$$

$$\text{MI} = \$27.03 / \text{CWT}$$

$$\% \text{ change} = ((\text{MI} / \text{BI}) - 1) = (\$27.03 / \$46.72 - 1) = (0.57855 - 1) = -0.421446917808$$

$$\text{Q} = 600,000 \text{ lbs.}$$

$$\text{SPA} = -0.421446917808 * \$46.72 * (600,000 / 100)$$

$$\text{SPA} = -0.421446917808 * \$46.72 * 6,000$$

$$\text{SPA} = \$ 118,140.00 \text{ Credit to the Department for Structural Steel (Structure 1 at Station 22+57.68)}$$

Price Adjustment Sample Calculation (increase)

Project bid on July 16, 2020

Line Item 614 Reinforced Concrete Deck Slab has a plan quantity of 241974 lbs.

Bidding Index Reference Month was May 2020. Bidding Index for Reinforced Concrete Deck Slab (Category 1) in the proposal was \$29.21/CWT = BI

51,621 lbs. of reinforcing steel and 52,311 lbs. of epoxy coated reinforcing steel for Structure 2 at Station 107+45.55 -L- was shipped to fabricator from the producing mill in same month, May 2021.

Monthly Index for Reinforced Concrete Deck Slab (Category 1) for May 2021 was \$43.13/CWT = MI

The Steel Price Adjustment formula is as follows:

$$\text{SPA} = ((\text{MI} / \text{BI}) - 1) * \text{BI} * (\text{Q} / 100)$$

Where; SPA = Steel price adjustment in dollars

BI = Bidding Index – in dollars (\$) per hundredweight (CWT). Use the adjustment indices as listed in the proposal.

MI = Mill Shipping Index – in dollars (\$) per hundredweight (CWT). Use the adjustment indices from the month the steel was shipped from the producing mill, received on the project, or member cast as defined in the Product Relationship Table.

Q = Quantity of steel product, in pounds (lbs.) actually incorporated into the work as documented by the Contractor, or Design Build Team and verified by the Engineer.

$$\text{BI} = \$29.21 / \text{CWT}$$

$$\text{MI} = \$43.13 / \text{CWT}$$

$$\% \text{ change} = ((\text{MI} / \text{BI}) - 1) = (\$43.13 / \$29.21 - 1) = (1.47655 - 1) = 0.47654912701$$

$$\text{Q} = 103932 \text{ lbs.}$$

$$\text{SPA} = 0.47654912701 * \$29.21 * (103,932 / 100)$$

$$\text{SPA} = 0.47654912701 * \$29.21 * 1,039.32$$

SPA = \$14,467.33 Pay Adjustment to Contractor for Reinforced Concrete Deck Slab (Category 1) at Station 107+45.55 -L-

SCHEDULE OF ESTIMATED COMPLETION PROGRESS:

(7-15-08)(Rev. 7-16-24)

108-2

SP1 G58

The Contractor's attention is directed to the Standard Special Provision entitled *Availability of Funds Termination of Contracts* included elsewhere in this proposal. The Department of Transportation's schedule of estimated completion progress for this project as required by that Standard Special Provision is as follows:

| | <u>Fiscal Year</u> | <u>Progress (% of Dollar Value)</u> |
|------|---------------------------|--|
| 2025 | (7/01/24 - 6/30/25) | 40% of Total Amount Bid |
| 2026 | (7/01/25 - 6/30/26) | 50% of Total Amount Bid |
| 2027 | (7/01/26 - 6/30/27) | 10% of Total Amount Bid |

The Contractor shall also furnish his own progress schedule in accordance with Article 108-2 of the *Standard Specifications*. Any acceleration of the progress as shown by the Contractor's progress schedule over the progress as shown above shall be subject to the approval of the Engineer.

MINORITY BUSINESS ENTERPRISE AND WOMEN BUSINESS ENTERPRISE:

(10-16-07)(Rev. 5-9-24)

102-15(J)

SP1 G66

Description

The purpose of this Special Provision is to carry out the North Carolina Department of Transportation's policy of ensuring nondiscrimination in the award and administration of contracts financed in whole or in part with State funds.

Definitions

Additional MBE/WBE Subcontractors - Any MBE/WBE submitted at the time of bid that will not be used to meet the Combined MBE /WBE Goal. No submittal of a Letter of Intent is required.

Combined MBE/WBE Goal: A portion of the total contract, expressed as a percentage that is to be performed by committed MBE/WBE subcontractors.

Committed MBE/WBE Subcontractor - Any MBE/WBE submitted at the time of bid that is being used to meet the Combined MBE /WBE goal by submission of a Letter of Intent. Or any MBE or WBE used as a replacement for a previously committed MBE or WBE firm.

Contract Goal Requirement - The approved participation at time of award, but not greater than the advertised Combined MBE/WBE contract goal.

Goal Confirmation Letter - Written documentation from the Department to the bidder confirming the Contractor's approved, committed participation along with a listing of the committed MBE and WBE firms.

Manufacturer - A firm that owns (or leases) and operates or maintains a factory or establishment that produces on the premises, the materials or supplies obtained by the Contractor. A firm that

makes minor modifications to the materials, supplies, articles, or equipment is not a manufacturer.

MBE Participation (Anticipated) - A portion of the total contract, expressed as a percentage that is anticipated to be performed by committed MBE subcontractor(s).

Minority Business Enterprise (MBE) - A firm certified as a Disadvantaged Minority-Owned Business Enterprise through the North Carolina Unified Certification Program.

Regular Dealer - A firm that owns (or leases), and operates a store, warehouse, or other establishment in which the materials or supplies required for the performance of the contract are bought, kept in sufficient quantities, and regularly sold to the public in the usual course of business. A regular dealer engages in, as its principal business and in its own name, the purchase and sale or lease of the products in question. A regular dealer in such bulk items as steel, concrete or concrete products, gravel, stone, asphalt and petroleum products need not keep such products in stock, if it owns and operates distribution equipment for the products. Any supplement of regular dealers' own distribution equipment shall be by a long-term operating lease and not on an ad hoc or contract-by-contract basis.

Distributor - A firm that engages in the regular sale or lease of the items specified by the contract. A distributor assumes responsibility for the items it purchases once they leave the point of origin (e.g., a manufacturer's facility), making it liable for any loss or damage not covered by the carrier's insurance.

Replacement / Substitution - A full or partial reduction in the amount of work subcontracted to a committed (or an approved substitute) MBE/WBE firm.

North Carolina Unified Certification Program (NCUCP) - A program that provides comprehensive services and information to applicants for MBE/WBE certification. The MBE/WBE program follows the same regulations as the federal Disadvantaged Business Enterprise (DBE) program in accordance with 49 CFR Part 26.

United States Department of Transportation (USDOT) - Federal agency responsible for issuing regulations (49 CFR Part 26) and official guidance for the DBE program.

WBE Participation (Anticipated) - A portion of the total contract, expressed as a percentage, that is anticipated to be performed by committed WBE subcontractor(s).

Women Business Enterprise (WBE) - A firm certified as a Disadvantaged Women-Owned Business Enterprise through the North Carolina Unified Certification Program.

Forms and Websites Referenced in this Provision

Payment Tracking System - On-line system in which the Contractor enters the payments made to MBE and WBE subcontractors who have performed work on the project.
<https://apps.dot.state.nc.us/Vendor/PaymentTracking/>

DBE-IS Subcontractor Payment Information - Form for reporting the payments made to all MBE/WBE firms working on the project. This form is for paper bid projects only.
<https://connect.ncdot.gov/business/Turnpike/Documents/Form%20DBE-IS%20Subcontractor%20Payment%20Information.pdf>

RF-1 MBE/WBE Replacement Request Form - Form for replacing a committed MBE or WBE.
<https://connect.ncdot.gov/projects/construction/Construction%20Forms/DBE%20MBE%20WBE%20Replacement%20Form%20and%20Instructions.pdf>

SAF Subcontract Approval Form - Form required for approval to sublet the contract.
<https://connect.ncdot.gov/projects/construction/Construction%20Forms/SAF%20Form%20-%20Subcontract%20Approval%20Form%20Revised%2004-19.xlsm>

JC-1 Joint Check Notification Form - Form and procedures for joint check notification. The form acts as a written joint check agreement among the parties providing full and prompt disclosure of the expected use of joint checks.
<http://connect.ncdot.gov/projects/construction/Construction%20Forms/Joint%20Check%20Notification%20Form.pdf>

Letter of Intent - Form signed by the Contractor and the MBE/WBE subcontractor, manufacturer or regular dealer that affirms that a portion of said contract is going to be performed by the signed MBE/WBE for the estimated amount (based on quantities and unit prices) listed at the time of bid.
<http://connect.ncdot.gov/letting/LetCentral/Letter%20of%20Intent%20to%20Perform%20as%20a%20Subcontractor.pdf>

Listing of MBE and WBE Subcontractors Form - Form for entering MBE/WBE subcontractors on a project that will meet the Combined MBE/WBE goal. This form is for paper bids only.
[http://connect.ncdot.gov/municipalities/Bid%20Proposals%20for%20LGA%20Content/09%20MBE-WBE%20Subcontractors%20\(State\).docx](http://connect.ncdot.gov/municipalities/Bid%20Proposals%20for%20LGA%20Content/09%20MBE-WBE%20Subcontractors%20(State).docx)

Subcontractor Quote Comparison Sheet - Spreadsheet for showing all subcontractor quotes in the work areas where MBEs and WBEs quoted on the project. This sheet is submitted with good faith effort packages.
<http://connect.ncdot.gov/business/SmallBusiness/Documents/DBE%20Subcontractor%20Quote%20Comparison%20Example.xls>

DBE Regular Dealer/Distributor Affirmation Form – Form is used to make a preliminary counting determination for each DBE listed as a regular dealer or distributor to assess its eligibility for 60 or 40 percent credit, respectively of the cost of materials or supplies based on its demonstrated capacity and intent to perform as a regular dealer or distributor, as defined in section 49 CFR 26.55 under the contract at issue. A Contractor will submit the completed form with the Letter of Intent.
<https://connect.ncdot.gov/projects/construction/Construction%20Forms/DBE%20Regular%20Dealer-Distributor%20Affirmation%20Form%20-%20USDOT%202024.pdf>

Combined MBE/WBE Goal

The Combined MBE/WBE Goal for this project is **5.0 %**

The Combined Goal was established utilizing the following anticipated participation for Minority Business Enterprises and Women Business Enterprises:

(A) Minority Business Enterprises **2.0 %**

- (1) *If the anticipated MBE participation is more than zero*, the Contractor shall exercise all necessary and reasonable steps to ensure that MBEs participate in at least the percent of the contract as set forth above.
- (2) *If the anticipated MBE participation is zero*, the Contractor shall make an effort to recruit and use MBEs during the performance of the contract. Any MBE participation obtained shall be reported to the Department.

(B) Women Business Enterprises **3.0 %**

- (1) *If the anticipated WBE participation is more than zero*, the Contractor shall exercise all necessary and reasonable steps to ensure that WBEs participate in at least the percent of the contract as set forth above.
- (2) *If the anticipated WBE participation is zero*, the Contractor shall make an effort to recruit and use WBEs during the performance of the contract. Any WBE participation obtained shall be reported to the Department.

The Bidder is required to submit only participation to meet the Combined MBE/WBE Goal. The Combined Goal may be met by submitting all MBE participation, all WBE participation, or a combination of MBE and WBE participation.

Directory of Transportation Firms (Directory)

Real-time information is available about firms doing business with the Department and firms that are certified through NCUCP in the Directory of Transportation Firms. Only firms identified in the Directory as MBE and WBE certified shall be used to meet the Combined MBE/WBE Goal. The Directory can be found at the following link.
<https://www.ebs.nc.gov/VendorDirectory/default.html>

The listing of an individual firm in the directory shall not be construed as an endorsement of the firm's capability to perform certain work.

Listing of MBE/WBE Subcontractors

At the time of bid, bidders shall submit all MBE and WBE participation that they anticipate to use during the life of the contract. Only those identified to meet the Combined MBE/WBE Goal will be considered committed, even though the listing shall include both committed MBE/WBE subcontractors and additional MBE/WBE subcontractors. Any additional MBE/WBE subcontractor participation above the goal will follow the banking guidelines found elsewhere in this provision. All other additional MBE/WBE subcontractor participation submitted at the time of bid will be used toward the Department's overall race-neutral goals. Only those firms with current MBE and WBE certification at the time of bid opening will be acceptable for listing in the bidder's submittal of MBE and WBE participation. The Contractor shall indicate the following required information:

(A) Electronic Bids

Bidders shall submit a listing of MBE and WBE participation in the appropriate section of the electronic submittal file.

- (1) Submit the names and addresses of MBE and WBE firms identified to participate in the contract. If the bidder uses the updated listing of MBE and WBE firms shown in the electronic submittal file, the bidder may use the dropdown menu to access the name and address of the firms.
- (2) Submit the contract line numbers of work to be performed by each MBE and WBE firm. When no figures or firms are entered, the bidder will be considered to have no MBE or WBE participation.
- (3) The bidder shall be responsible for ensuring that the MBE and WBE are certified at the time of bid by checking the Directory of Transportation Firms. If the firm is not certified at the time of the bid-letting, that MBE's or WBE's participation will not count towards achieving the Combined MBE/WBE goal.

(B) Paper Bids

- (1) *If the Combined MBE/WBE Goal is more than zero,*
 - (a) Bidders, at the time the bid proposal is submitted, shall submit a listing of MBE/WBE participation, including the names and addresses on *Listing of MBE and WBE Subcontractors* contained elsewhere in the contract documents in order for the bid to be considered responsive. Bidders shall indicate the total dollar value of the MBE and WBE participation for the contract.
 - (b) If bidders have no MBE or WBE participation, they shall indicate this on the *Listing of MBE and WBE Subcontractors* by entering the word "None" or the number "0." This form shall be completed in its entirety. **Blank forms will not be deemed to represent zero participation.** Bids submitted that do not have MBE and WBE participation indicated on the

appropriate form will not be read publicly during the opening of bids. The Department will not consider these bids for award and the proposal will be rejected.

- (c) The bidder shall be responsible for ensuring that the MBE/WBE is certified at the time of bid by checking the Directory of Transportation Firms. If the firm is not certified at the time of the bid-letting, that MBE's or WBE's participation will not count towards achieving the Combined MBE/WBE Goal.
- (2) *If the Combined MBE/WBE Goal is zero*, entries on the *Listing of MBE and WBE Subcontractors* are not required for the zero goal, however any MBE or WBE participation that is achieved during the project shall be reported in accordance with requirements contained elsewhere in the special provision.

MBE or WBE Prime Contractor

When a certified MBE or WBE firm bids on a contract that contains a Combined MBE/WBE goal, the firm is responsible for meeting the goal or making good faith efforts to meet the goal, just like any other bidder. In most cases, a MBE or WBE bidder on a contract will meet the Combined MBE/WBE Goal by virtue of the work it performs on the contract with its own forces. However, all the work that is performed by the MBE or WBE bidder and any other similarly certified subcontractors will count toward the goal. The MBE or WBE bidder shall list itself along with any MBE or WBE subcontractors, if any, in order to receive credit toward the goal.

MBE/WBE prime contractors shall also follow Sections A and B listed under *Listing of MBE/WBE Subcontractor* just as a non-MBE/WBE bidder would.

Written Documentation – Letter of Intent

The bidder shall submit written documentation for each MBE/WBE that will be used to meet the Combined MBE/WBE Goal of the contract, indicating the bidder's commitment to use the MBE/WBE in the contract. This documentation shall be submitted on the Department's form titled *Letter of Intent*.

The documentation shall be received in the office of the State Contractor Utilization Engineer or at DBE@ncdot.gov no later than 10:00 a.m. of the sixth calendar day following opening of bids, unless the sixth day falls on an official state holiday. In that situation, it is due in the office of the State Contractor Utilization Engineer no later than 10:00 a.m. on the next official state business day.

If the bidder fails to submit the Letter of Intent from each committed MBE and WBE to be used toward the Combined MBE/WBE Goal, or if the form is incomplete (i.e. both signatures are not present), the MBE/WBE participation will not count toward meeting the Combined MBE/WBE Goal. If the lack of this participation drops the commitment below the Combined MBE/WBE Goal, the Contractor shall submit evidence of good faith efforts for the goal, completed in its entirety, to the State Contractor Utilization Engineer or DBE@ncdot.gov no later than 10:00 a.m. on the eighth calendar day following opening of bids, unless the eighth day falls on an official

state holiday. In that situation, it is due in the office of the State Contractor Utilization Engineer no later than 10:00 a.m. on the next official state business day.

Banking MBE/WBE Credit

If the bid of the lowest responsive bidder exceeds \$500,000 and if the committed MBE/WBE participation submitted exceeds the algebraic sum of the Combined MBE /WBE Goal by \$1,000 or more, the excess will be placed on deposit by the Department for future use by the bidder. Separate accounts will be maintained for MBE and WBE participation and these may accumulate for a period not to exceed 24 months.

When the apparent lowest responsive bidder fails to submit sufficient participation by MBE and WBE firms to meet the advertised goal, as part of the good faith effort, the Department will consider allowing the bidder to withdraw funds to meet the Combined MBE/WBE Goal as long as there are adequate funds available from the bidder's MBE and WBE bank accounts.

Submission of Good Faith Effort

If the bidder fails to meet or exceed the Combined MBE/WBE Goal, the apparent lowest responsive bidder shall submit to the Department documentation of adequate good faith efforts made to reach that specific goal.

A hard copy and an electronic copy of this information shall be received in the office of the State Contractor Utilization Engineer or at DBE@ncdot.gov no later than 10:00 a.m. on the sixth calendar day following opening of bids unless the sixth day falls on an official state holiday. In that situation, it would be due in the office of the State Contractor Utilization Engineer no later than 10:00 a.m. on the next official state business day. If the Contractor cannot send the information electronically, then one complete set and 5 copies of this information shall be received under the same time constraints above.

Note: Where the information submitted includes repetitious solicitation letters, it will be acceptable to submit a representative letter along with a distribution list of the firms that were solicited. Documentation of MBE/WBE quotations shall be a part of the good faith effort submittal. This documentation may include written subcontractor quotations, telephone log notations of verbal quotations, or other types of quotation documentation.

Consideration of Good Faith Effort for Projects with a Combined MBE/WBE Goal More Than Zero

Adequate good faith efforts mean that the bidder took all necessary and reasonable steps to achieve the goal which, by their scope, intensity, and appropriateness, could reasonably be expected to obtain sufficient MBE/WBE participation. Adequate good faith efforts also mean that the bidder actively and aggressively sought MBE/WBE participation. Mere *pro forma* efforts are not considered good faith efforts.

The Department will consider the quality, quantity, and intensity of the different kinds of efforts a bidder has made. Listed below are examples of the types of actions a bidder will take in making a good faith effort to meet the goals and are not intended to be exclusive or exhaustive, nor is it intended to be a mandatory checklist.

- (A) Soliciting through all reasonable and available means (e.g. attendance at pre-bid meetings, advertising, written notices, use of verifiable electronic means through the use of the NCDOT Directory of Transportation Firms) the interest of all certified MBEs/WBEs that are also prequalified subcontractors. The bidder must solicit this interest within at least 10 days prior to bid opening to allow the MBEs/WBEs to respond to the solicitation. Solicitation shall provide the opportunity to MBEs/WBEs within the Division and surrounding Divisions where the project is located. The bidder must determine with certainty if the MBEs/WBEs are interested by taking appropriate steps to follow up initial solicitations.
- (B) Selecting portions of the work to be performed by MBEs/WBEs in order to increase the likelihood that the Combined MBE/WBE Goal will be achieved.
 - (1) Where appropriate, break out contract work items into economically feasible units to facilitate MBE/WBE participation, even when the prime contractor might otherwise prefer to perform these work items with its own forces.
 - (2) Negotiate with subcontractors to assume part of the responsibility to meet the advertised goal when the work to be sublet includes potential for MBE/WBE participation (2nd and 3rd tier subcontractors).
- (C) Providing interested certified MBEs/WBEs that are also prequalified subcontractors with adequate information about the plans, specifications, and requirements of the contract in a timely manner to assist them in responding to a solicitation.
- (D)
 - (1) Negotiating in good faith with interested MBEs/WBEs. It is the bidder's responsibility to make a portion of the work available to MBE/WBE subcontractors and suppliers and to select those portions of the work or material needs consistent with the available MBE/WBE subcontractors and suppliers, so as to facilitate MBE/WBE participation. Evidence of such negotiation includes the names, addresses, and telephone numbers of MBEs/WBEs that were considered; a description of the information provided regarding the plans and specifications for the work selected for subcontracting; and evidence as to why additional agreements could not be reached for MBEs/WBEs to perform the work.
 - (2) A bidder using good business judgment would consider a number of factors in negotiating with subcontractors, including MBE/WBE subcontractors, and would take a firm's price and capabilities as well as the advertised goal into consideration. However, the fact that there may be some additional costs involved in finding and using MBEs/WBEs is not in itself sufficient reason for a bidder's failure to meet the contract goal, as long as such costs are reasonable. Also, the ability or desire of a prime contractor to perform the work of a contract with its own organization does not relieve the bidder of the responsibility to make

good faith efforts. Bidding contractors are not, however, required to accept higher quotes from MBEs/WBEs if the price difference is excessive or unreasonable.

- (E) Not rejecting MBEs/WBEs as being unqualified without sound reasons based on a thorough investigation of their capabilities. The bidder's standing within its industry, membership in specific groups, organizations, or associates and political or social affiliations (for example, union vs. non-union employee status) are not legitimate causes for the rejection or non-solicitation of bids in the bidder's efforts to meet the project goal.
- (F) Making efforts to assist interested MBEs/WBEs in obtaining bonding, lines of credit, or insurance as required by the recipient or bidder.
- (G) Making efforts to assist interested MBEs/WBEs in obtaining necessary equipment, supplies, materials, or related assistance or services.
- (H) Effectively using the services of available minority/women community organizations; minority/women contractors' groups; Federal, State, and local minority/women business assistance offices; and other organizations as allowed on a case-by-case basis to provide assistance in the recruitment and placement of MBEs/WBEs. Contact within 7 days from the bid opening the Business Opportunity and Work Force Development Unit at BOWD@ncdot.gov to give notification of the bidder's inability to get MBE or WBE quotes.
- (I) Any other evidence that the bidder submits which shows that the bidder has made reasonable good faith efforts to meet the advertised goal.

In addition, the Department may take into account the following:

- (1) Whether the bidder's documentation reflects a clear and realistic plan for achieving the Combined MBE/WBE Goal.
- (2) The bidders' past performance in meeting the contract goal.
- (3) The performance of other bidders in meeting the advertised goal. For example, when the apparent successful bidder fails to meet the goal, but others meet it, you may reasonably raise the question of whether, with additional reasonable efforts the apparent successful bidder could have met the goal. If the apparent successful bidder fails to meet the advertised goal, but meets or exceeds the average MBE and WBE participation obtained by other bidders, the Department may view this, in conjunction with other factors, as evidence of the apparent successful bidder having made a good faith effort.

If the Department does not award the contract to the apparent lowest responsive bidder, the Department reserves the right to award the contract to the next lowest responsive bidder that can satisfy to the Department that the Combined MBE/WBE Goal can be met or that an adequate good faith effort has been made to meet the advertised goal.

Non-Good Faith Appeal

The State Prequalification Engineer will notify the Contractor verbally and in writing of non-good faith. A Contractor may appeal a determination of non-good faith made by the Goal Compliance Committee. If a Contractor wishes to appeal the determination made by the Committee, they shall provide written notification to the State Prequalification Engineer. The appeal shall be made within 2 business days of notification of the determination of non-good faith.

Counting MBE/WBE Participation Toward Meeting the Combined MBE/WBE Goal**(A) Participation**

The total dollar value of the participation by a committed MBE/WBE will be counted toward the contract goal requirements. The total dollar value of participation by a committed MBE/WBE will be based upon the value of work performed by the MBE/WBE and the actual payments to MBE/WBE firms by the Contractor.

(B) Joint Checks

Prior notification of joint check use shall be required when counting MBE/WBE participation for services or purchases that involves the use of a joint check. Notification shall be through submission of Form JC-1 (*Joint Check Notification Form*) and the use of joint checks shall be in accordance with the Department's Joint Check Procedures.

(C) Subcontracts (Non-Trucking)

A MBE/WBE may enter into subcontracts. Work that a MBE subcontracts to another MBE firm may be counted toward the anticipated MBE participation. The same holds true for work that a WBE subcontracts to another WBE firm. Work that a MBE/WBE subcontracts to a non-MBE/WBE firm does not count toward the contract goal requirement. It should be noted that every effort shall be made by MBE and WBE contractors to subcontract to the same certification (i.e., MBEs to MBEs and WBEs to WBEs), in order to fulfill the MBE or WBE participation breakdown. This, however, may not always be possible due to the limitation of firms in the area. If the MBE or WBE firm shows a good faith effort has been made to reach out to similarly certified firms and there is no interest or availability, and they can get assistance from other certified firms, the Engineer will not hold the prime responsible for meeting the individual MBE or WBE breakdown. If a MBE or WBE contractor or subcontractor subcontracts a significantly greater portion of the work of the contract than would be expected on the basis of standard industry practices, it shall be presumed that the MBE or WBE is not performing a commercially useful function.

(D) Joint Venture

When a MBE or WBE performs as a participant in a joint venture, the Contractor may count toward its contract goal requirement a portion of the total value of participation

with the MBE or WBE in the joint venture, that portion of the total dollar value being a distinct clearly defined portion of work that the MBE or WBE performs with its forces.

(F) Manufacturer, Regular Dealer, Distributor

A Contractor may count toward its MBE/WBE requirement 40 percent of its expenditures for materials or supplies (including transportation costs) from a MBE/WBE distributor, 60 percent of its expenditures for materials or supplies (including transportation costs) from a MBE/WBE regular dealer and 100 percent of such expenditures obtained from a MBE/WBE manufacturer.

A Contractor may count toward its MBE/WBE requirement the following expenditures to MBE/WBE firms that are not manufacturers, regular dealers or distributors:

- (1) The fees or commissions charged by a MBE/WBE firm for providing a *bona fide* service, such as professional, technical, consultant, or managerial services, or for providing bonds or insurance specifically required for the performance of a DOT-assisted contract, provided the fees or commissions are determined to be reasonable and not excessive as compared with fees and commissions customarily allowed for similar services.
- (2) With respect to materials or supplies purchased from a MBE/WBE, which is neither a manufacturer, regular dealer, nor a distributor count the entire amount of fees or commissions charged that the Department deems to be reasonable, including transportation charges for the delivery of materials or supplies. Do not count any portion of the cost of the materials and supplies themselves.

A Contractor will submit a completed *DBE Regular Dealer/Distributor Affirmation Form* with the Letter of Intent to the State Contractor Utilization Engineer or DBE@ncdot.gov. The State Contractor Utilization Engineer will make a preliminary assessment as to whether a MBE/WBE supplier has the demonstrated capacity to perform a commercially useful function (CUF) on a contract-by-contract basis *prior* to its participation.

Commercially Useful Function**(A) MBE/WBE Utilization**

The Contractor may count toward its contract goal requirement only expenditures to MBEs and WBEs that perform a commercially useful function in the work of a contract. A MBE/WBE performs a commercially useful function when it is responsible for execution of the work of the contract and is carrying out its responsibilities by performing, managing, and supervising the work involved. To perform a commercially useful function, the MBE/WBE shall also be responsible with respect to materials and supplies used on the contract, for negotiating price, determining quality and quantity, ordering the material and installing (where applicable) and paying for the material itself. To determine whether a MBE/WBE is performing a commercially useful function, the Department will evaluate the amount of work subcontracted, industry practices, whether the amount the firm is to be paid under the contract is commensurate with the work it is performing and the MBE/WBE credit claimed for its performance of the work, and any other relevant factors. If it is determined that a MBE or WBE is not performing a Commercially Useful Function, the contractor may present evidence to rebut this presumption to the Department.

(B) MBE/WBE Utilization in Trucking

The following factors will be used to determine if a MBE or WBE trucking firm is performing a commercially useful function:

- (1) The MBE/WBE shall be responsible for the management and supervision of the entire trucking operation for which it is responsible on a particular contract, and there shall not be a contrived arrangement for the purpose of meeting the Combined MBE/WBE Goal.
- (2) The MBE/WBE shall itself own and operate at least one fully licensed, insured, and operational truck used on the contract.
- (3) The MBE/WBE receives credit for the total value of the transportation services it provides on the contract using trucks it owns, insures, and operates using drivers it employs.
- (4) The MBE may subcontract the work to another MBE firm, including an owner-operator who is certified as a MBE. The same holds true that a WBE may subcontract the work to another WBE firm, including an owner-operator who is certified as a WBE. When this occurs, the MBE or WBE who subcontracts work receives credit for the total value of the transportation services the subcontracted MBE or WBE provides on the contract. It should be noted that every effort shall be made by MBE and WBE contractors to subcontract to the same certification (i.e., MBEs to MBEs and WBEs to WBEs), in order to fulfill the participation breakdown. This, however, may not always be possible due to the limitation of firms in the area. If the MBE or WBE firm shows a good faith

effort has been made to reach out to similarly certified transportation service providers and there is no interest or availability, and they can get assistance from other certified providers, the Engineer will not hold the prime responsible for meeting the individual MBE or WBE participation breakdown.

- (5) The MBE/WBE may also subcontract the work to a non-MBE/WBE firm, including from an owner-operator. The MBE/WBE who subcontracts the work to a non-MBE/WBE is entitled to credit for the total value of transportation services provided by the non-MBE/WBE subcontractor not to exceed the value of transportation services provided by MBE/WBE-owned trucks on the contract. Additional participation by non-MBE/WBE subcontractors receives credit only for the fee or commission it receives as a result of the subcontract arrangement. The value of services performed under subcontract agreements between the MBE/WBE and the Contractor will not count towards the MBE/WBE contract requirement.
- (6) A MBE/WBE may lease truck(s) from an established equipment leasing business open to the general public. The lease must indicate that the MBE/WBE has exclusive use of and control over the truck. This requirement does not preclude the leased truck from working for others during the term of the lease with the consent of the MBE/WBE, so long as the lease gives the MBE/WBE absolute priority for use of the leased truck. This type of lease may count toward the MBE/WBE's credit as long as the driver is under the MBE/WBE's payroll.
- (7) Subcontracted/leased trucks shall display clearly on the dashboard the name of the MBE/WBE that they are subcontracted/leased to and their own company name if it is not identified on the truck itself. Magnetic door signs are not permitted.

MBE/WBE Replacement

When a Contractor has relied on a commitment to a MBE or WBE subcontractor (or an approved substitute MBE or WBE subcontractor) to meet all or part of a contract goal requirement, the contractor shall not terminate the MBE/WBE subcontractor or any portion of its work for convenience. This includes, but is not limited to, instances in which the Contractor seeks to perform the work of the terminated subcontractor with another MBE/WBE subcontractor, a non-MBE/WBE subcontractor, or with the Contractor's own forces or those of an affiliate.

The Contractor must give notice in writing both by certified mail and email to the MBE/WBE subcontractor, with a copy to the Engineer of its intent to request to terminate a MBE/WBE subcontractor or any portion of its work, and the reason for the request. The Contractor must give the MBE/WBE subcontractor five (5) business days to respond to the Contractor's Notice of Intent to Request Termination and/or Substitution. If the MBE/WBE subcontractor objects to the intended termination/substitution, the MBE/WBE, within five (5) business days must advise the Contractor and the Department of the reasons why the action should not be approved. The five-day notice period shall begin on the next business day after written notice is provided to the MBE/WBE subcontractor.

A committed MBE/WBE subcontractor may only be terminated or any portion of its work after receiving the Department's written approval based upon a finding of good cause for the proposed termination and/or substitution. Good cause does not exist if the Contractor seeks to terminate a MBE/WBE or any portion of its work that it relied upon to obtain the contract so that the Contractor can self-perform the work for which the MBE/WBE was engaged, or so that the Contractor can substitute another MBE/WBE or non-MBE/WBE contractor after contract award. For purposes of this section, good cause shall include the following circumstances:

- (a) The listed MBE/WBE subcontractor fails or refuses to execute a written contract;
- (b) The listed MBE/WBE subcontractor fails or refuses to perform the work of its subcontract in a way consistent with normal industry standards. Provided, however, that good cause does not exist if the failure or refusal of the MBE/WBE subcontractor to perform its work on the subcontract results from the bad faith or discriminatory action of the prime contractor;
- (c) The listed MBE/WBE subcontractor fails or refuses to meet the prime contractor's reasonable, nondiscriminatory bond requirements;
- (d) The listed MBE/WBE subcontractor becomes bankrupt, insolvent, or exhibits credit unworthiness;
- (e) The listed MBE/WBE subcontractor is ineligible to work on public works projects because of suspension and debarment proceedings pursuant to 2 CFR parts 180, 215 and 1200 or applicable State law;
- (f) The listed MBE/WBE subcontractor is not a responsible contractor;
- (g) The listed MBE/WBE voluntarily withdraws from the project and provides written notice of withdrawal;
- (h) The listed MBE/WBE is ineligible to receive MBE/WBE credit for the type of work required;
- (i) A MBE/WBE owner dies or becomes disabled with the result that the listed MBE/WBE contractor is unable to complete its work on the contract; and
- (j) Other documented good cause that compels the termination of the MBE/WBE subcontractor.

The Contractor shall comply with the following for replacement of a committed MBE/WBE:

(A) Performance Related Replacement

When a committed MBE/WBE is terminated for good cause as stated above, an additional MBE/WBE that was submitted at the time of bid may be used to fulfill the MBE/WBE commitment to meet the Combined MBE/WBE Goal. A good faith effort will only be required for removing a committed MBE/WBE if there were no additional MBE/WBEs submitted at the time of bid to cover the same amount of work as the MBE/WBE that was terminated.

If a replacement MBE/WBE is not found that can perform at least the same amount of work as the terminated MBE/WBE, the Contractor shall submit a good faith effort documenting the steps taken. Such documentation shall include, but not be limited to, the following:

- (1) Copies of written notification to MBE/WBEs that their interest is solicited in contracting the work defaulted by the previous MBE/WBE or in subcontracting other items of work in the contract.
 - (2) Efforts to negotiate with MBE/WBEs for specific subbids including, at a minimum:
 - (a) The names, addresses, and telephone numbers of MBE/WBEs who were contacted.
 - (b) A description of the information provided to MBE/WBEs regarding the plans and specifications for portions of the work to be performed.
 - (3) A list of reasons why MBE/WBE quotes were not accepted.
 - (4) Efforts made to assist the MBE/WBEs contacted, if needed, in obtaining bonding or insurance required by the Contractor.
- (B) Decertification Replacement
- (1) When a committed MBE/WBE is decertified by the Department after the SAF (*Subcontract Approval Form*) has been received by the Department, the Department will not require the Contractor to solicit replacement MBE/WBE participation equal to the remaining work to be performed by the decertified firm. The participation equal to the remaining work performed by the decertified firm will count toward the contract goal requirement but not the overall goal.
 - (i) If the MBE/WBE's ineligibility is caused solely by its having exceeded the size standard during the performance of the contract. The Department may continue to count participation equal to the remaining work performed by the decertified firm which will count toward the contract goal requirement and overall goal.
 - (ii) If the MBE/WBE's ineligibility is caused solely by its acquisition by or merger with a non- MBE/WBE during the performance of the contract. The Department may not continue to count the portion of the decertified firm's performance on the contract remaining toward either the contract goal or the overall goal, even if the Contractor has executed a subcontract with the firm or the Department has executed a prime contract with the MBE/WBE that was later decertified.
 - (2) When a committed MBE/WBE is decertified prior to the Department receiving the SAF (*Subcontract Approval Form*) for the named MBE/WBE firm, the

Contractor shall take all necessary and reasonable steps to replace the MBE/WBE subcontractor with another MBE/WBE subcontractor to perform at least the same amount of work to meet the Combined MBE/WBE goal requirement. If a MBE/WBE firm is not found to do the same amount of work, a good faith effort must be submitted to NCDOT (see A herein for required documentation).

All requests for replacement of a committed MBE/WBE firm shall be submitted to the Engineer for approval on Form RF-1 (*DBE Replacement Request*). If the Contractor fails to follow this procedure, the Contractor may be disqualified from further bidding for a period of up to 6 months.

Changes in the Work

When the Engineer makes changes that result in the reduction or elimination of work to be performed by a committed MBE/WBE, the Contractor will not be required to seek additional participation. When the Engineer makes changes that result in additional work to be performed by a MBE/WBE based upon the Contractor's commitment, the MBE/WBE shall participate in additional work to the same extent as the MBE/WBE participated in the original contract work.

When the Engineer makes changes that result in extra work, which has more than a minimal impact on the contract amount, the Contractor shall seek additional participation by MBEs/WBEs unless otherwise approved by the Engineer.

When the Engineer makes changes that result in an alteration of plans or details of construction, and a portion or all of the work had been expected to be performed by a committed MBE/WBE, the Contractor shall seek participation by MBEs/WBEs unless otherwise approved by the Engineer.

When the Contractor requests changes in the work that result in the reduction or elimination of work that the Contractor committed to be performed by a MBE/WBE, the Contractor shall seek additional participation by MBEs/WBEs equal to the reduced MBE/WBE participation caused by the changes.

Reports and Documentation

A SAF (*Subcontract Approval Form*) shall be submitted for all work which is to be performed by a MBE/WBE subcontractor. The Department reserves the right to require copies of actual subcontract agreements involving MBE/WBE subcontractors.

When using transportation services to meet the contract commitment, the Contractor shall submit a proposed trucking plan in addition to the SAF. The plan shall be submitted prior to beginning construction on the project. The plan shall include the names of all trucking firms proposed for use, their certification type(s), the number of trucks owned by the firm, as well as the individual truck identification numbers, and the line item(s) being performed.

Within 30 calendar days of entering into an agreement with a MBE/WBE for materials, supplies or services, not otherwise documented by the SAF as specified above, the Contractor shall

furnish the Engineer a copy of the agreement. The documentation shall also indicate the percentage (60% or 100%) of expenditures claimed for MBE/WBE credit.

Reporting Minority and Women Business Enterprise Participation

The Contractor shall provide the Engineer with an accounting of payments made to all MBE/WBE firms, including material suppliers and contractors at all levels (prime, subcontractor, or second tier subcontractor). This accounting shall be furnished to the Engineer for any given month by the end of the following month. Failure to submit this information accordingly may result in the following action:

- (A) Withholding of money due in the next partial pay estimate; or
- (B) Removal of an approved contractor from the prequalified bidders' list or the removal of other entities from the approved subcontractors list.

While each contractor (prime, subcontractor, 2nd tier subcontractor) is responsible for accurate accounting of payments to MBEs/WBEs, it shall be the prime contractor's responsibility to report all monthly and final payment information in the correct reporting manner.

Failure on the part of the Contractor to submit the required information in the time frame specified may result in the disqualification of that contractor and any affiliate companies from further bidding until the required information is submitted.

Failure on the part of any subcontractor to submit the required information in the time frame specified may result in the disqualification of that contractor and any affiliate companies from being approved for work on future DOT projects until the required information is submitted.

Contractors reporting transportation services provided by non-MBE/WBE lessees shall evaluate the value of services provided during the month of the reporting period only.

At any time, the Engineer can request written verification of subcontractor payments.

The Contractor shall report the accounting of payments through the Department's Payment Tracking System.

Failure to Meet Contract Requirements

Failure to meet contract requirements in accordance with Subarticle 102-15(J) of the *Standard Specifications* may be cause to disqualify the Contractor.

RESTRICTIONS ON ITS EQUIPMENT AND SERVICES:

(11-17-20)

SP01 G090

All telecommunications, video or other ITS equipment or services installed or utilized on this project must be in conformance with UNIFORM ADMINISTRATIVE REQUIREMENTS, COST PRINCIPLES, AND AUDIT REQUIREMENTS FOR FEDERAL AWARDS **2 CFR, § 200.216 Prohibition on certain telecommunications and video surveillance services or equipment.**

USE OF UNMANNED AIRCRAFT SYSTEM (UAS):

(8-20-19)

SP1 G092

The Contractor shall adhere to all Federal, State and Local regulations and guidelines for the use of Unmanned Aircraft Systems (UAS). This includes but is not limited to US 14 CFR Part 107 *Small UAS Rule*, NC GS 15A-300.2 *Regulation of launch and recovery sites*, NC GS 63-95 *Training required for the operation of unmanned aircraft systems*, NC GS 63-96 *Permit required for commercial operation of unmanned aircraft system*, and NCDOT UAS Policy. The required operator certifications include possessing a current Federal Aviation Administration (FAA) Remote Pilot Certificate, a NC UAS Operator Permit as well as operating a UAS registered with the FAA.

Prior to beginning operations, the Contractor shall complete the NCDOT UAS – Flight Operation Approval Form and submit it to the Engineer for approval. All UAS operations shall be approved by the Engineer prior to beginning the operations.

All contractors or subcontractors operating UAS shall have UAS specific general liability insurance to cover all operations under this contract.

The use of UAS is at the Contractor's discretion. No measurement or payment will be made for the use of UAS. In the event that the Department directs the Contractor to utilize UAS, payment will be in accordance with Article 104-7 Extra Work.

EQUIPMENT IDLING GUIDELINES:

(1-19-21)

107

SP1 G096

Exercise reduced fuel consumption and reduced equipment emissions during the construction of all work associated with this contract. Employees engaged in the construction of this project should turn off vehicles when stopped for more than thirty (30) minutes and off-highway equipment should idle no longer than fifteen (15) consecutive minutes.

These guidelines for turning off vehicles and equipment when idling do not apply to:

1. Idling when queuing.
2. Idling to verify the vehicle is in safe operating condition.
3. Idling for testing, servicing, repairing or diagnostic purposes.
4. Idling necessary to accomplish work for which the vehicle was designed (such as operating a crane, mixing concrete, etc.).
5. Idling required to bring the machine system to operating temperature.

6. Emergency vehicles, utility company, construction, and maintenance vehicles where the engines must run to perform needed work.
7. Idling to ensure safe operation of the vehicle.
8. Idling when the propulsion engine is providing auxiliary power for other than heating or air conditioning. (such as hydraulic systems for pavers)
9. When specific traffic, safety, or emergency situations arise.
10. If the ambient temperature is less than 32 degrees Fahrenheit. Limited idling to provide for the safety of vehicle occupants (e.g. to run the heater).
11. If the ambient temperature is greater than 90 degrees Fahrenheit. Limited idling to provide for the safety of vehicle occupants of off-highway equipment (e.g. to run the air conditioning) no more than 30 minutes.
12. Diesel powered vehicles may idle for up to 30 minutes to minimize restart problems.

Any vehicle, truck, or equipment in which the primary source of fuel is natural gas or electricity is exempt from the idling limitations set forth in this special provision.

SUBSURFACE INFORMATION:

(7-1-95)(Rev. 8-16-22)

450

SP1 G112 A

Subsurface information is available on the roadway portion of this project.

MAINTENANCE OF THE PROJECT:

(11-20-07)(Rev. 1-16-24)

104-10

SP1 G125

Revise the *Standard Specifications* as follows:

Page 1-35, Article 104-10 Maintenance of the Project, line 3, add the following after the first sentence of the first paragraph:

All guardrail/guiderail within the project limits shall be included in this maintenance.

Page 1-35, Article 104-10 MAINTENANCE OF THE PROJECT, line 8, add the following as the last sentence of the first paragraph:

The Contractor shall perform weekly inspections of guardrail and guiderail and shall report damages to the Engineer on the same day of the weekly inspection. *Where damaged guardrail or guiderail is repaired or replaced as a result of maintaining the project in accordance with this article, such repair or replacement shall be performed within 7 consecutive calendar days of such inspection report.*

Page 1-35, Article 104-10 MAINTENANCE OF THE PROJECT, lines 20-22, replace the last sentence of the last paragraph with the following:

The Contractor will not be directly compensated for any maintenance operations necessary, except for maintenance of guardrail/guiderail, as this work will be considered incidental to the work covered by the various contract items. The provisions of Article 104-7, Extra Work, and Article 104-8, Compensation and Record Keeping will apply to authorized maintenance of guardrail/guiderail. Performance of weekly inspections of guardrail/guiderail, and the damage

reports required as described above, will be considered to be an incidental part of the work being paid for by the various contract items.

COOPERATION BETWEEN CONTRACTORS:

(7-1-95)(Rev. 1-16-24)

105-7

SP1 G133

The Contractor's attention is directed to Article 105-7 of the *Standard Specifications*.

Maps #2 & #7 of the 2024CPT.09.01.10291, etc. resurfacing package (C204906) are located adjacent to this project. C204906 is currently under construction and not anticipated to be complete prior to the letting of this project.

The Contractor on this project shall cooperate with the Contractor working within or adjacent to the limits of this project to the extent that the work can be carried out to the best advantage of all concerned.

TWELVE MONTH GUARANTEE:

(7-15-03)

108

SP1 G145

- (A) The Contractor shall guarantee materials and workmanship against latent and patent defects arising from faulty materials, faulty workmanship or negligence for a period of twelve months following the date of final acceptance of the work for maintenance and shall replace such defective materials and workmanship without cost to the Department. The Contractor will not be responsible for damage due to faulty design, normal wear and tear, for negligence on the part of the Department, and/or for use in excess of the design.
- (B) Where items of equipment or material carry a manufacturer's guarantee for any period in excess of twelve months, then the manufacturer's guarantee shall apply for that particular piece of equipment or material. The Department's first remedy shall be through the manufacturer although the Contractor is responsible for invoking the warranted repair work with the manufacturer. The Contractor's responsibility shall be limited to the term of the manufacturer's guarantee. NCDOT would be afforded the same warranty as provided by the Manufacturer.

This guarantee provision shall be invoked only for major components of work in which the Contractor would be wholly responsible for under the terms of the contract. Examples would include pavement structures, bridge components, and sign structures. This provision will not be used as a mechanism to force the Contractor to return to the project to make repairs or perform additional work that the Department would normally compensate the Contractor for. In addition, routine maintenance activities (i.e. mowing grass, debris removal, ruts in earth shoulders,) are not parts of this guarantee.

Appropriate provisions of the payment and/or performance bonds shall cover this guarantee for the project.

To ensure uniform application statewide the Division Engineer will forward details regarding the circumstances surrounding any proposed guarantee repairs to the Chief Engineer for review and approval prior to the work being performed.

OUTSOURCING OUTSIDE THE USA:

(9-21-04) (Rev. 5-16-06)

SPI G150

All work on consultant contracts, services contracts, and construction contracts shall be performed in the United States of America. No work shall be outsourced outside of the United States of America.

Outsourcing for the purpose of this provision is defined as the practice of subcontracting labor, work, services, staffing, or personnel to entities located outside of the United States.

The North Carolina Secretary of Transportation shall approve exceptions to this provision in writing.

EROSION AND SEDIMENT CONTROL/STORMWATER CERTIFICATION:

(1-16-07) (Rev 12-15-20)

105-16, 225-2, 16

SPI G180

General

Schedule and conduct construction activities in a manner that will minimize soil erosion and the resulting sedimentation and turbidity of surface waters. Comply with the requirements herein regardless of whether or not a National Pollution discharge Elimination System (NPDES) permit for the work is required.

Establish a chain of responsibility for operations and subcontractors' operations to ensure that the *Erosion and Sediment Control/Stormwater Pollution Prevention Plan* is implemented and maintained over the life of the contract.

- (A) *Certified Supervisor* - Provide a certified Erosion and Sediment Control/Stormwater Supervisor to manage the Contractor and subcontractor operations, insure compliance with Federal, State and Local ordinances and regulations, and manage the Quality Control Program.
- (B) *Certified Foreman* - Provide a certified, trained foreman for each construction operation that increases the potential for soil erosion or the possible sedimentation and turbidity of surface waters.
- (C) *Certified Installer* - Provide a certified installer to install or direct the installation for erosion or sediment/stormwater control practices.
- (D) *Certified Designer* - Provide a certified designer for the design of the erosion and sediment control/stormwater component of reclamation plans and, if applicable, for the design of the project erosion and sediment control/stormwater plan.

Roles and Responsibilities

- (A) *Certified Erosion and Sediment Control/Stormwater Supervisor* - The Certified Supervisor shall be Level II and responsible for ensuring the erosion and sediment control/stormwater plan is adequately implemented and maintained on the project and for conducting the quality control program. The Certified Supervisor shall be on the project

within 24 hours notice from initial exposure of an erodible surface to the project's final acceptance. Perform the following duties:

- (1) Manage Operations - Coordinate and schedule the work of subcontractors so that erosion and sediment control/stormwater measures are fully executed for each operation and in a timely manner over the duration of the contract.
 - (a) Oversee the work of subcontractors so that appropriate erosion and sediment control/stormwater preventive measures are conformed to at each stage of the work.
 - (b) Prepare the required National Pollutant Discharge Elimination System (NPDES) Inspection Record and submit to the Engineer.
 - (c) Attend all weekly or monthly construction meetings to discuss the findings of the NPDES inspection and other related issues.
 - (d) Implement the erosion and sediment control/stormwater site plans requested.
 - (e) Provide any needed erosion and sediment control/stormwater practices for the Contractor's temporary work not shown on the plans, such as, but not limited to work platforms, temporary construction, pumping operations, plant and storage yards, and cofferdams.
 - (f) Acquire applicable permits and comply with requirements for borrow pits, dewatering, and any temporary work conducted by the Contractor in jurisdictional areas.
 - (g) Conduct all erosion and sediment control/stormwater work in a timely and workmanlike manner.
 - (h) Fully perform and install erosion and sediment control/stormwater work prior to any suspension of the work.
 - (i) Coordinate with Department, Federal, State and Local Regulatory agencies on resolution of erosion and sediment control/stormwater issues due to the Contractor's operations.
 - (j) Ensure that proper cleanup occurs from vehicle tracking on paved surfaces or any location where sediment leaves the Right-of-Way.
 - (k) Have available a set of erosion and sediment control/stormwater plans that are initialed and include the installation date of Best Management Practices. These practices shall include temporary and permanent groundcover and be properly updated to reflect necessary plan and field changes for use and review by Department personnel as well as regulatory agencies.
- (2) Requirements set forth under the NPDES Permit - The Department's NPDES Stormwater permit (NCS000250) outlines certain objectives and management measures pertaining to construction activities. The permit references *NCG010000, General Permit to Discharge Stormwater* under the NPDES, and states that the Department shall incorporate the applicable requirements into its delegated Erosion and Sediment Control Program for construction activities disturbing one or more acres of land. The Department further incorporates these requirements on all contracted bridge and culvert work at jurisdictional waters, regardless of size. Some of the requirements are, but are not limited to:

- (a) Control project site waste to prevent contamination of surface or ground waters of the state, i.e. from equipment operation/maintenance, construction materials, concrete washout, chemicals, litter, fuels, lubricants, coolants, hydraulic fluids, any other petroleum products, and sanitary waste.
 - (b) Inspect erosion and sediment control/stormwater devices and stormwater discharge outfalls at least once every 7 calendar days and within 24 hours after a rainfall event equal to or greater than 1.0 inch that occurs within a 24 hour period. Additional monitoring may be required at the discretion of Division of Water Resources personnel if the receiving stream is 303(d) listed for turbidity and the project has had documented problems managing turbidity.
 - (c) Maintain an onsite rain gauge or use the Department's Multi-Sensor Precipitation Estimate website to maintain a daily record of rainfall amounts and dates.
 - (d) Maintain erosion and sediment control/stormwater inspection records for review by Department and Regulatory personnel upon request.
 - (e) Implement approved reclamation plans on all borrow pits, waste sites and staging areas.
 - (f) Maintain a log of turbidity test results as outlined in the Department's Procedure for Monitoring Borrow Pit Discharge.
 - (g) Provide secondary containment for bulk storage of liquid materials.
 - (h) Provide training for employees concerning general erosion and sediment control/stormwater awareness, the Department's NPDES Stormwater Permit NCS000250 requirements, and the applicable requirements of the *General Permit, NCG010000*.
 - (i) Report violations of the NPDES permit to the Engineer immediately who will notify the Division of Water Quality Regional Office within 24 hours of becoming aware of the violation.
- (3) Quality Control Program - Maintain a quality control program to control erosion, prevent sedimentation and follow provisions/conditions of permits. The quality control program shall:
- (a) Follow permit requirements related to the Contractor and subcontractors' construction activities.
 - (b) Ensure that all operators and subcontractors on site have the proper erosion and sediment control/stormwater certification.
 - (c) Notify the Engineer when the required certified erosion and sediment control/stormwater personnel are not available on the job site when needed.
 - (d) Conduct the inspections required by the NPDES permit.
 - (e) Take corrective actions in the proper timeframe as required by the NPDES permit for problem areas identified during the NPDES inspections.
 - (f) Incorporate erosion control into the work in a timely manner and stabilize disturbed areas with mulch/seed or vegetative cover on a section-by-section basis.

- (g) Use flocculants approved by state regulatory authorities where appropriate and where required for turbidity and sedimentation reduction.
 - (h) Ensure proper installation and maintenance of temporary erosion and sediment control devices.
 - (i) Remove temporary erosion or sediment control devices when they are no longer necessary as agreed upon by the Engineer.
 - (j) The Contractor's quality control and inspection procedures shall be subject to review by the Engineer. Maintain NPDES inspection records and make records available at all times for verification by the Engineer.
- (B) *Certified Foreman* - At least one Certified Foreman shall be onsite for each type of work listed herein during the respective construction activities to control erosion, prevent sedimentation and follow permit provisions:
- (1) Foreman in charge of grading activities
 - (2) Foreman in charge of bridge or culvert construction over jurisdictional areas
 - (3) Foreman in charge of utility activities

The Contractor may request to use the same person as the Level II Supervisor and Level II Foreman. This person shall be onsite whenever construction activities as described above are taking place. This request shall be approved by the Engineer prior to work beginning.

The Contractor may request to name a single Level II Foreman to oversee multiple construction activities on small bridge or culvert replacement projects. This request shall be approved by the Engineer prior to work beginning.

- (C) *Certified Installers* - Provide at least one onsite, Level I Certified Installer for each of the following erosion and sediment control/stormwater crew:
- (1) Seeding and Mulching
 - (2) Temporary Seeding
 - (3) Temporary Mulching
 - (4) Sodding
 - (5) Silt fence or other perimeter erosion/sediment control device installations
 - (6) Erosion control blanket installation
 - (7) Hydraulic tackifier installation
 - (8) Turbidity curtain installation
 - (9) Rock ditch check/sediment dam installation
 - (10) Ditch liner/matting installation
 - (11) Inlet protection
 - (12) Riprap placement
 - (13) Stormwater BMP installations (such as but not limited to level spreaders, retention/detention devices)
 - (14) Pipe installations within jurisdictional areas

If a Level I *Certified Installer* is not onsite, the Contractor may substitute a Level II Foreman for a Level I Installer, provided the Level II Foreman is not tasked to another crew requiring Level II Foreman oversight.

- (D) *Certified Designer* - Include the certification number of the Level III Certified Designer on the erosion and sediment control/stormwater component of all reclamation plans and if applicable, the certification number of the Level III Certified Designer on the design of the project erosion and sediment control/stormwater plan.

Preconstruction Meeting

Furnish the names of the *Certified Erosion and Sediment Control/Stormwater Supervisor*, *Certified Foremen*, *Certified Installers* and *Certified Designer* and notify the Engineer of changes in certified personnel over the life of the contract within 2 days of change.

Ethical Responsibility

Any company performing work for the North Carolina Department of Transportation has the ethical responsibility to fully disclose any reprimand or dismissal of an employee resulting from improper testing or falsification of records.

Revocation or Suspension of Certification

Upon recommendation of the Chief Engineer to the certification entity, certification for *Supervisor*, *Certified Foremen*, *Certified Installers* and *Certified Designer* may be revoked or suspended with the issuance of an *Immediate Corrective Action (ICA)*, *Notice of Violation (NOV)*, or *Cease and Desist Order* for erosion and sediment control/stormwater related issues.

The Chief Engineer may recommend suspension or permanent revocation of certification due to the following:

- (A) Failure to adequately perform the duties as defined within this certification provision.
- (B) Issuance of an ICA, NOV, or Cease and Desist Order.
- (C) Failure to fully perform environmental commitments as detailed within the permit conditions and specifications.
- (D) Demonstration of erroneous documentation or reporting techniques.
- (E) Cheating or copying another candidate's work on an examination.
- (F) Intentional falsification of records.
- (G) Directing a subordinate under direct or indirect supervision to perform any of the above actions.
- (H) Dismissal from a company for any of the above reasons.
- (I) Suspension or revocation of one's certification by another entity.

Suspension or revocation of a certification will be sent by certified mail to the certificant and the Corporate Head of the company that employs the certificant.

A certificant has the right to appeal any adverse action which results in suspension or permanent revocation of certification by responding, in writing, to the Chief Engineer within 10 calendar days after receiving notice of the proposed adverse action.

Chief Engineer
1536 Mail Service Center
Raleigh, NC 27699-1536

Failure to appeal within 10 calendar days will result in the proposed adverse action becoming effective on the date specified on the certified notice. Failure to appeal within the time specified will result in a waiver of all future appeal rights regarding the adverse action taken. The certificant will not be allowed to perform duties associated with the certification during the appeal process.

The Chief Engineer will hear the appeal and make a decision within 7 days of hearing the appeal. Decision of the Chief Engineer will be final and will be made in writing to the certificant.

If a certification is temporarily suspended, the certificant shall pass any applicable written examination and any proficiency examination, at the conclusion of the specified suspension period, prior to having the certification reinstated.

Measurement and Payment

Certified Erosion and Sediment Control/Stormwater Supervisor, Certified Foremen, Certified Installers and Certified Designer will be incidental to the project for which no direct compensation will be made.

PROCEDURE FOR MONITORING BORROW PIT DISCHARGE:

(2-20-07) (Rev. 1-16-24)

105-16, 230, 801

SP1 G181

Water discharge from borrow pit sites shall not cause surface waters to exceed 50 NTUs (nephelometric turbidity unit) in streams not designated as trout waters and 10 NTUs in streams, lakes or reservoirs designated as trout waters. For lakes and reservoirs not designated as trout waters, the turbidity shall not exceed 25 NTUs. If the turbidity exceeds these levels due to natural background conditions, the existing turbidity level shall not be increased.

If during any operating day, the downstream water quality exceeds the standard, the Contractor shall do all of the following:

- (A) Either cease discharge or modify the discharge volume or turbidity levels to bring the downstream turbidity levels into compliance, or
- (B) Evaluate the upstream conditions to determine if the exceedance of the standard is due to natural background conditions. If the background turbidity measurements exceed the standard, operation of the pit and discharge can continue as long as the stream turbidity levels are not increased due to the discharge.

- (C) Measure and record the turbidity test results (time, date and sampler) at all defined sampling locations 30 minutes after startup and at a minimum, one additional sampling of all sampling locations during that 24-hour period in which the borrow pit is discharging.
- (D) Notify DWQ within 24 hours of any stream turbidity standard exceedances that are not brought into compliance.

During the Environmental Assessment required by Article 230-4 of the *Standard Specifications*, the Contractor shall define the point at which the discharge enters into the State's surface waters and the appropriate sampling locations. Sampling locations shall include points upstream and downstream from the point at which the discharge enters these waters. Upstream sampling location shall be located so that it is not influenced by backwater conditions and represents natural background conditions. Downstream sampling location shall be located at the point where complete mixing of the discharge and receiving water has occurred.

The discharge shall be closely monitored when water from the dewatering activities is introduced into jurisdictional wetlands. Any time visible sedimentation (deposition of sediment) on the wetland surface is observed, the dewatering activity will be suspended until turbidity levels in the stilling basin can be reduced to a level where sediment deposition does not occur. Staining of wetland surfaces from suspended clay particles, occurring after evaporation or infiltration, does not constitute sedimentation. No activities shall occur in wetlands that adversely affect the functioning of a wetland. Visible sedimentation will be considered an indication of possible adverse impacts on wetland use.

The Engineer will perform independent turbidity tests on a random basis. These results will be maintained in a log within the project records. Records will include, at a minimum, turbidity test results, time, date and name of sampler. Should the Department's test results exceed those of the Contractor's test results, an immediate test shall be performed jointly with the results superseding the previous test results of both the Department and the Contractor.

The Contractor shall use the *NCDOT Turbidity Reduction Options for Borrow Pits Matrix*, available at <https://connect.ncdot.gov/resources/roadside/FieldOperationsDocuments/TurbidityReductionOptionSheet.pdf> to plan, design, construct, and maintain BMPs to address water quality standards. Tier I Methods include stilling basins which are standard compensatory BMPs. Other Tier I methods are noncompensatory and shall be used when needed to meet the stream turbidity standards. Tier II Methods are also noncompensatory and are options that may be needed for protection of rare or unique resources or where special environmental conditions exist at the site which have led to additional requirements being placed in the DWQ's 401 Certifications and approval letters, Isolated Wetland Permits, Riparian Buffer Authorization or a DOT Reclamation Plan's Environmental Assessment for the specific site. Should the Contractor exhaust all Tier I Methods on a site exclusive of rare or unique resources or special environmental conditions, Tier II Methods may be required by regulators on a case by case basis per supplemental agreement.

The Contractor may use cation exchange capacity (CEC) values from proposed site borings to plan and develop the bid for the project. CEC values exceeding 15 milliequivalents per 100 grams of soil may indicate a high potential for turbidity and should be avoided when dewatering into surface water is proposed.

No additional compensation for monitoring borrow pit discharge will be paid.

NOTE TO CONTRACTOR:

No separate payment will be made for pole foundation removals four linear feet below finished grade as shown on plan sheet 4. Payment will be included in the lump sum Grading pay item.

PROJECT SPECIAL PROVISIONS**ROADWAY****CLEARING AND GRUBBING - METHOD II:**

(9-17-02)(Rev. 3-19-24)

200

SP2 R02A

Perform clearing on this project to the limits established by Method - II shown on Standard Drawing No. 200.02 of the *Roadway Standard Drawings*. Conventional clearing methods may be used except where permit drawings or conditions have been included in the proposal which require certain areas to be cleared by hand methods.

BURNING RESTRICTIONS:

(7-1-95)

200, 210, 215

SP2 R05

Open burning is not permitted on any portion of the right-of-way limits established for this project. Do not burn the clearing, grubbing or demolition debris designated for disposal and generated from the project at locations within the project limits, off the project limits or at any waste or borrow sites in this county. Dispose of the clearing, grubbing and demolition debris by means other than burning, according to state or local rules and regulations.

SHOULDER AND FILL SLOPE MATERIAL:

(5-21-02)(Rev. 1-16-24)

235, 560

SP2 R45 A

Description

Perform the required shoulder and slope construction for this project in accordance with the applicable requirements of Section 560 and Section 235 of the *Standard Specifications*.

Measurement and Payment

Where the material has been obtained from an authorized stockpile or from a borrow source and *Borrow Excavation* is not included in the contract, no direct payment will be made for this work, as the cost of this work will be part of the work being paid at the contract lump sum price for *Grading*. If *Borrow Excavation* is included in this contract and the material has been obtained from an authorized stockpile or from a borrow source, measurement and payment will be as provided in Section 230 of the *Standard Specifications* for *Borrow Excavation*.

MANUFACTURED QUARRY FINES IN EMBANKMENTS:

(01-17-17)(Rev. 4-16-24)

235

SP02 R72

Description

This specification addresses the use of manufactured quarry fines that are not classified as select materials. The specification allows the Contractor an option, with the approval of the Engineer, to use manufactured quarry fines (MQFs) in embankments as a substitute for conventional borrow material. Furnish and place geotextile for subgrade stabilization in accordance with the contract. Geotextile for subgrade stabilization is required to prevent pavement cracking and provide separation between the subgrade and pavement section at embankment locations where

manufactured quarry fines are utilized and as directed by the Engineer.

Materials

Manufactured Quarry Fines.

Site specific approval of MQFs material will be required prior to beginning construction as detailed in the preconstruction requirements of this provision.

The following MQFs are unacceptable:

- (A) Frozen material,
- (B) Material with a maximum dry unit weight of less than 90 pounds per cubic foot when tested in accordance with AASHTO T 99 Method A or C.
- (C) Material with greater than 80% by weight Passing the #200 sieve

Collect and transport MQFs in a manner that will prevent nuisances and hazards to public health and safety. Moisture condition the MQFs as needed and transport in covered trucks to prevent dusting. If MQFs are blended with natural earth material, follow Borrow Criteria in Section 1018 of the *Standard Specifications*.

Preconstruction Requirements

When MQFs are to be used as a substitute for earth borrow material, request written approval from the Engineer at least ninety (90) days in advance of the intent to use MQFs and include the following details:

- (A) Description, purpose and location of project.
- (B) Estimated start and completion dates of project.
- (C) Estimated volume of MQFs to be used on project with specific locations and construction details of the placement.
- (D) The names, address, and contact information for the generator of the MQFs.
- (E) Physical location of the site at which the MQFs were generated.

The Engineer will forward this information to the State Materials Engineer for review and material approval.

Construction Methods

Place MQFs in the core of the embankment section with at least 4 feet of earth cover to the outside limits of the embankments or subgrade.

Construct embankments by placing MQFs in level uniform lifts with no more than a lift of 10 inches and compacted to at least a density of 95 percent as determined by test methods in AASHTO T 99, Determination of Maximum Dry Density and Optimum Moisture Content, Method A or C depending upon particle size of the product. Provide a moisture content at the time of compaction of within 4 percent of optimum but not greater than one percent above optimum as determined by AASHTO T 99, Method A or C.

In embankments where MQFs are incorporated, geotextile for subgrade stabilization shall be used. Refer to Article 505-2 of the *Standard Specifications* for geotextile type and Article 505-3 of the *Standard Specifications* for the geotextile construction methods.

Measurement and Payment

Borrow Excavation will be measured by truck volume and paid in cubic yards in accordance with Article 230-5 of the *Standard Specifications*. As an alternate weigh tickets can be provided and payment made by converting weight to cubic yards based on the verifiable unit weight. Where the pay item for *Borrow Excavation* is not included in the original contract then no separate payment will be made for this item and payment will be included in the lump sum price bid for *Grading*.

Geotextile for Subgrade Stabilization will be measured and paid in accordance with Article 505-4 of the *Standard Specifications*. When the pay item for *Geotextile for Subgrade Stabilization* is not included in the original contract then no payment will be made for this item and will be considered incidental to the use of MQFs in embankment.

CORRUGATED ALUMINUM ALLOY CULVERT PIPE:

(9-21-21)(Rev. 1-16-24)

305, 310

SP3 R34

Revise the *Standard Specifications* as follows:

Page 3-5, Article 305-2, MATERIALS, add the following after line 16:

| Item | Section |
|------------------|----------------|
| Waterborne Paint | 1080-9 |
| Hot Bitumen | 1081-3 |

Page 3-5, Article 305-3, CONSTRUCTION METHODS, add the following after line 26:

Coating must be applied to the aluminum when in contact with concrete. Immediately prior to coating, aluminum surfaces to be coated shall be cleaned by a method that will remove all dirt, oil, grease, chips, and other foreign substances. Aluminum to be coated shall be given one coat of suitable quality coating such as:

Approved waterborne paint (Section 1080-9)
Approved Hot Bitumen (Section 1081-3)

Other coating materials may be submitted to the Engineer for approval.

Page 3-7, Article 310-6, MEASUREMENT AND PAYMENT, lines 10-11, delete the fourth sentence and replace with the following:

Select bedding and backfill material and coating will be included in the cost of the installed pipe.

PRICE ADJUSTMENT - ASPHALT BINDER FOR PLANT MIX:

(11-21-00)(Rev. 1-16-24)

620

SP6 R25

Price adjustments for asphalt binder for plant mix will be made in accordance with Section 620 of the *Standard Specifications*.

The base price index for asphalt binder for plant mix is **\$ 595.00** per ton.

This base price index represents an average of F.O.B. selling prices of asphalt binder at supplier's terminals on **August 1, 2024**.

FINAL SURFACE TESTING NOT REQUIRED:

(5-18-04) (Rev. 2-16-16)

610

SP6 R45

Final surface testing is not required on this project in accordance with Section 610-13, *Final Surface Testing and Acceptance*.

MODIFIED CONCRETE FLUME WITH CONCRETE OUTLET:

(3-19-96)(Rev. 1-16-24)

825

SP8 R10

At locations shown in the plans, construct concrete flumes, concrete curb, and apron in accordance with the details in the plans. Use materials meeting the requirements of Section 825 of the *Standard Specifications* except that the concrete must be Class B or of higher compressive strength.

Each concrete flume, concrete curb, and apron completed and accepted will be paid at the contract unit price per each for *Modified Concrete Flume*. Such price and payment will be full compensation for all materials, labor, equipment, tools, removing and disposing of the temporary slope drains, and any other incidentals necessary to complete the work satisfactorily.

The concrete curb and ditch outside the pay limits of the apron will be measured and paid in accordance with Section 846 and 850 of the *Standard Specifications*.

Payment will be made under:

| Pay Item | Pay Unit |
|-------------------------|-----------------|
| Modified Concrete Flume | Each |

FOUNDATIONS AND ANCHOR ROD ASSEMBLIES FOR METAL POLES:

(1-17-12)(Rev. 1-16-24)

9, 14, 17

SP9 R05

Description

Foundations for metal poles include foundations for signals, cameras, overhead and dynamic message signs (DMS) and high mount and light standards supported by metal poles or upright trusses. Foundations consist of footings with pedestals and drilled piers with or without grade beams or wings. Anchor rod assemblies consist of anchor rods (also called anchor bolts) with nuts and washers on the exposed ends of rods and nuts and a plate or washers on the other ends of rods embedded in the foundation.

Construct concrete foundations with the required resistances and dimensions and install anchor rod assemblies in accordance with the contract and accepted submittals. Construct drilled piers consisting of cast-in-place reinforced concrete cylindrical sections in excavated holes. Provide temporary casings or polymer slurry as needed to stabilize drilled pier excavations. Use a prequalified Drilled Pier Contractor to construct drilled piers for metal poles. Define “excavation” and “hole” as a drilled pier excavation and “pier” as a drilled pier.

This provision does not apply to foundations for signal pedestals; see Section 1743 of the *Standard Specifications* and Roadway Standard Drawing No. 1743.01.

Materials

Refer to the *Standard Specifications*.

| Item | Section |
|--------------------------|----------------|
| Conduit | 1091-3 |
| Grout, Type 2 | 1003 |
| Polymer Slurry | 411-2(B)(2) |
| Portland Cement Concrete | 1000 |
| Reinforcing Steel | 1070 |
| Rollers and Chairs | 411-2(C) |
| Temporary Casings | 411-2(A) |

Provide Type 3 material certifications in accordance with Article 106-3 of the *Standard Specifications* for conduit, rollers, chairs and anchor rod assemblies. Store steel materials on blocking at least 12" above the ground and protect it at all times from damage; and when placing in the work make sure it is free from dirt, dust, loose mill scale, loose rust, paint, oil or other foreign materials. Load, transport, unload and store foundation and anchor rod assembly materials so materials are kept clean and free of damage. Bent, damaged or defective materials will be rejected.

Use conduit type in accordance with the contract. Use Class A concrete for footings and pedestals, Class Drilled Pier concrete for drilled piers and Class AA concrete for grade beams and wings including portions of drilled piers above bottom of wings elevations. Corrugated temporary casings may be accepted at the discretion of the Engineer. A list of approved polymer slurry products is available from:

connect.ncdot.gov/resources/Geological/Pages/Products.aspx

Provide anchor rod assemblies in accordance with the contract consisting of the following:

- (A) Straight anchor rods,
- (B) Heavy hex top and leveling nuts and flat washers on exposed ends of rods, and
- (C) Nuts and either flat plates or washers on the other ends of anchor rods embedded in foundations.

Do not use lock washers. Use steel anchor rods, nuts and washers that meet ASTM F1554 for Grade 55 rods and Grade A nuts. Use steel plates and washers embedded in concrete with a thickness of at least 1/4". Galvanize anchor rods and exposed nuts and washers in accordance with Article 1076-4 of the *Standard Specifications*. It is not necessary to galvanize nuts, plates and washers embedded in concrete.

Construction Methods

Install the required size and number of conduits in foundations in accordance with the plans and accepted submittals. Construct top of piers, footings, pedestals, grade beams and wings flat, level and within 1" of elevations shown in the plans or approved by the Engineer. Provide an Ordinary Surface finish in accordance with Subarticle 825-6(B) of the *Standard Specifications* for portions of foundations exposed above finished grade. Do not remove anchor bolt templates or pedestal or grade beam forms or erect metal poles or upright trusses onto foundations until concrete attains a compressive strength of at least 3,000 psi.

(A) Drilled Piers

Before starting drilled pier construction, hold a predrill meeting to discuss the installation, monitoring and inspection of the drilled piers. Schedule this meeting after the Drilled Pier Contractor has mobilized to the site. The Resident or Division Traffic Engineer, Contractor and Drilled Pier Contractor Superintendent will attend this predrill meeting.

Do not excavate holes, install piles or allow equipment wheel loads or vibrations within 20 ft of completed piers until 16 hours after Drilled Pier concrete reaches initial set.

Check for correct drilled pier alignment and location before beginning drilling. Check plumbness of holes frequently during drilling.

Construct drilled piers with the minimum required diameters shown in the plans. Install piers with tip elevations no higher than shown in the plans or approved by the Engineer.

Excavate holes with equipment of the sizes required to construct drilled piers. Depending on the subsurface conditions encountered, drilling through rock and boulders may be required. Do not use blasting for drilled pier excavations.

Contain and dispose of drilling spoils and waste concrete as directed and in accordance with Section 802 of the *Standard Specifications*. Drilling spoils consist of all materials and fluids removed from excavations.

If unstable, caving or sloughing materials are anticipated or encountered, stabilize holes with temporary casings and/or polymer slurry. Do not use telescoping temporary casings. If it becomes necessary to replace a temporary casing during drilling, backfill the excavation, insert a larger casing around the casing to be replaced or stabilize the excavation with polymer slurry before removing the temporary casing.

If temporary casings become stuck or the Contractor proposes leaving casings in place, temporary casings should be installed against undisturbed material. Unless otherwise approved, do not leave temporary casings in place for mast arm poles and cantilever signs. The Engineer will determine if casings may remain in place. If the Contractor proposes leaving temporary casings in place, do not begin drilling until a casing installation method is approved.

Use polymer slurry and additives to stabilize holes in accordance with the slurry manufacturer's recommendations. Provide mixing water and equipment suitable for polymer slurry. Maintain the required slurry properties at all times except for sand content.

Define a "sample set" as slurry samples collected from mid-height and within 2 ft of the bottom of holes. Take sample sets from excavations to test polymer slurry immediately after filling holes with slurry, at least every 4 hours thereafter and immediately before placing concrete. Do not place Drilled Pier concrete until both slurry samples from an excavation meet the required polymer slurry properties. If any slurry test results do not meet the requirements, the Engineer may suspend drilling until both samples from a sample set meet the required polymer slurry properties.

Remove soft and loose material from bottom of holes using augers to the satisfaction of the Engineer. Assemble rebar cages and place cages and Drilled Pier concrete in accordance with Subarticle 411-4(E) of the *Standard Specifications* except for the following:

- (1) Inspections for tip resistance and bottom cleanliness are not required,
- (2) Temporary casings may remain in place if approved, and
- (3) Concrete placement may be paused near the top of pier elevations for anchor rod assembly installation and conduit placement or
- (4) If applicable, concrete placement may be stopped at bottom of grade beam or wings elevations for grade beam or wing construction.

If wet placement of concrete is anticipated or encountered, do not place Drilled Pier concrete until a concrete placement procedure is approved. If applicable, temporary casings and fluids may be removed when concrete placement is paused or stopped in accordance with the exceptions above provided holes are stable. Remove contaminated concrete from exposed Drilled Pier concrete after removing casings and fluids. If holes are unstable, do not remove temporary casings until a procedure for placing anchor rod assemblies and conduit or constructing grade beams or wings is approved.

Use collars to extend drilled piers above finished grade. Remove collars after Drilled Pier concrete sets and round top edges of piers.

If drilled piers are questionable, pile integrity testing (PIT) and further investigation may be required in accordance with Article 411-5 of the *Standard Specifications*. A drilled pier will be considered defective in accordance with Subarticle 411-5(D) of the *Standard Specifications* and drilled pier acceptance is based in part on the criteria in Article 411-6

of the *Standard Specifications* except for the top of pier tolerances in Subarticle 411-6(C) of the *Standard Specifications*.

If a drilled pier is under further investigation, do not grout core holes, backfill around the pier or perform any work on the drilled pier until the Engineer accepts the pier. If the drilled pier is accepted, dewater and grout core holes and backfill around the pier with approved material to finished grade. If the Engineer determines a pier is unacceptable, remediation is required in accordance with Article 411-6 of the *Standard Specifications*. No extension of completion date or time will be allowed for remediation of unacceptable drilled piers or post repair testing.

Permanently embed a plate in or mark top of piers with the pier diameter and depth, size and number of vertical reinforcing bars and the minimum compressive strength of the concrete mix at 28 days.

(B) Footings, Pedestals, Grade Beams and Wings

Excavate as necessary for footings, grade beams and wings in accordance with the plans, accepted submittals and Section 410 of the *Standard Specifications*. If unstable, caving or sloughing materials are anticipated or encountered, shore foundation excavations as needed with an approved method. Notify the Engineer when foundation excavation is complete. Do not place concrete or reinforcing steel until excavation dimensions and foundation material are approved.

Construct cast-in-place reinforced concrete footings, pedestals, grade beams and wings with the dimensions shown in the plans and in accordance with Section 825 of the *Standard Specifications*. Use forms to construct portions of pedestals and grade beams protruding above finished grade. Provide a chamfer with a 3/4" horizontal width for pedestal and grade beam edges exposed above finished grade. Place concrete against undisturbed soil or backfill and fill in accordance with Article 410-8 of the *Standard Specifications*. Proper compaction around footings and wings is critical for foundations to resist uplift and torsion forces.

(C) Anchor Rod Assemblies

Size anchor rods for design and the required projection above top of foundations. Determine required anchor rod projections from nut, washer and base plate thicknesses, the protrusion of 3 to 5 anchor rod threads above top nuts after tightening and the distance of one nut thickness between top of foundations and bottom of leveling nuts.

Protect anchor rod threads from damage during storage and installation of anchor rod assemblies. Before placing anchor rods in foundations, turn nuts onto and off rods past leveling nut locations. Turn nuts with the effort of one workman using an ordinary wrench without a cheater bar. Report any thread damage to the Engineer that requires extra effort to turn nuts.

Arrange anchor rods symmetrically about center of base plate locations as shown in the plans. Set anchor rod elevations based on required projections above top of foundations.

Securely brace and hold rods in the correct position, orientation and alignment with a steel template. Do not weld to reinforcing steel, temporary casings or anchor rods.

Install top and leveling (bottom) nuts, washers and the base plate for each anchor rod assembly in accordance with the following procedure:

- (1) Turn leveling nuts onto anchor rods to a distance of one nut thickness between the top of foundation and bottom of leveling nuts. Place washers over anchor rods on top of leveling nuts.
- (2) Determine if nuts are level using a flat rigid template on top of washers. If necessary, lower leveling nuts to level the template in all directions or if applicable, lower nuts to tilt the template so the metal pole or upright truss will lean as shown in the plans. If leveling nuts and washers are not in full contact with the template, replace washers with galvanized beveled washers.
- (3) Verify the distance between the foundation and leveling nuts is no more than one nut thickness.
- (4) Place base plate with metal pole or upright truss over anchor rods on top of washers. High mount luminaires may be attached before erecting metal poles but do not attach cables, mast arms or trusses to metal poles or upright trusses at this time.
- (5) Place washers over anchor rods on top of base plate. Lubricate top nut bearing surfaces and exposed anchor rod threads above washers with beeswax, paraffin or other approved lubricant.
- (6) Turn top nuts onto anchor rods. If nuts are not in full contact with washers or washers are not in full contact with the base plate, replace washers with galvanized beveled washers.
- (7) Tighten top nuts to snug-tight with the full effort of one workman using a 12" wrench. Do not tighten any nut all at once. Turn top nuts in increments. Follow a star pattern cycling through each nut at least twice.
- (8) Repeat (7) for leveling nuts.
- (9) Replace washers above and below the base plate with galvanized beveled washers if the slope of any base plate face exceeds 1:20 (5%), any washer is not in firm contact with the base plate or any nut is not in firm contact with a washer. If any washers are replaced, repeat (7) and (8).

- (10) With top and leveling nuts snug-tight, mark each top nut on a corner at the intersection of 2 flats and a corresponding reference mark on the base plate. Mark top nuts and base plate with ink or paint that is not water-soluble. Use the turn-of-nut method for pretensioning. Do not pretension any nut all at once. Turn top nuts in increments for a total turn that meets the following nut rotation requirements:

| NUT ROTATION REQUIREMENTS (Turn-of-Nut Pretensioning Method) | |
|---|--------------------|
| Anchor Rod Diameter, inch | Requirement |
| $\leq 1 \frac{1}{2}$ | 1/3 turn (2 flats) |
| $> 1 \frac{1}{2}$ | 1/6 turn (1 flat) |

Follow a star pattern cycling through each top nut at least twice.

- (11) Ensure nuts, washers and base plate are in firm contact with each other for each anchor rod. Cables, mast arms and trusses may now be attached to metal poles and upright trusses.
- (12) Between 4 and 14 days after pretensioning top nuts, use a torque wrench calibrated within the last 12 months to check nuts in the presence of the Engineer. Completely erect mast arm poles and cantilever signs and attach any hardware before checking top nuts for these structures. Check that top nuts meet the following torque requirements:

| TORQUE REQUIREMENTS | |
|----------------------------------|---------------------------|
| Anchor Rod Diameter, inch | Requirement, ft-lb |
| 7/8 | 180 |
| 1 | 270 |
| 1 1/8 | 380 |
| 1 1/4 | 420 |
| $\geq 1 \frac{1}{2}$ | 600 |

If necessary, retighten top nuts in the presence of the Engineer with a calibrated torque wrench to within ± 10 ft-lb of the required torque. Do not overtighten top nuts.

- (13) Do not grout under base plate.

Measurement and Payment

Foundations and anchor rod assemblies for metal poles and upright trusses will be measured and paid for elsewhere in the contract.

No payment will be made for temporary casings that remain in drilled pier excavations. No payment will be made for PIT. No payment will be made for further investigation of defective piers. Further investigation of piers that are not defective will be paid as extra work in accordance with Article 104-7 of the *Standard Specifications*. No payment will be made for remediation of unacceptable drilled piers or post repair testing.

ELECTRONIC TICKETING SYSTEM:

(7-16-24)

1020

SP10 R20

Description

At the contractor's option, the use of an electronic ticketing system for reporting individual and cumulative asphalt material deliveries may be utilized on this project. At the preconstruction conference, the contractor shall notify the Engineer if they intend to utilize an electronic ticketing system for reporting individual and cumulative asphalt material deliveries to the project.

Electronic Ticketing Requirements

- a. The electronic ticketing system must be fully integrated with the load read-out system at the plant. The system shall be designed so data inputs from scales cannot be altered by either the Contractor or the Department.
- b. Material supplier must test to confirm that ticketing data can be shared from the originating system no less than 30 days prior to project start.
- c. After each truck is loaded, ticket data must be electronically captured, and ticket information uploaded via Application Programming Interface (API) to the Department.
- d. Obtain security token from NCDOT for access to E-Ticketing portal (to send tickets). To request a Security Key, fill out the below E-Ticketing Security Request Form: <https://forms.office.com/g/XnT7QeRtgt>
- e. Obtain API from NCDOT containing the required e-ticketing data fields and format. Download the API from the NCDOT E-ticketing Webpage: <https://connect.ncdot.gov/projects/construction/E-Ticketing/Pages/default.aspx>
- f. Provide all ticket information in real time and daily summaries to the Department's designated web portal. If the project contains locations with limited cellular service, an alternative course of action must be agreed upon.
- g. Electronic ticketing submissions must be sent between the Material Supplier and the Department.
- h. The electronic ticket shall contain the following information:

Date
Time
Contract Number
Supplier Name
Contractor Name
Material
JMF

Gross Weight
Tare Weight
Net Weight
Load Number
Cumulative Weight
Truck Number
Weighmaster Certification
Weighmaster Expiration
Weighmaster Name
Facility Name
Plant Type
Plant Number
Ticket Number
Voided Ticket Number (if necessary)
Original Ticket Number (if necessary)
Supplier Revision (If necessary)

The Contractor/supplier can use the electronic ticketing system of their choice to meet the requirements of this provision.

Measurement and Payment

No measurement or payment will be made for utilizing an electronic ticketing system as the cost of such shall be included in the contract price bid for the material being provided.

GLASS BEAD GRADATION FOR PAVEMENT MARKINGS:

(9-17-24)

1087

SP10 R87

Revise the *Standard Specifications* as follows:

Page 10-187, Subarticle 1087-4(C), Gradation & Roundness, after line 6, delete and replace Table 1087-2 with the following:

| TABLE 1087-2 GLASS BEAD GRADATION REQUIREMENTS | | |
|---|-------------------------------|----------------|
| Sieve Size | Gradation Requirements | |
| | Minimum | Maximum |
| Passing #20 | 100% | -- |
| Retained on #30 | 5% | 15% |
| Retained on #50 | 40% | 80% |
| Retained on #80 | 15% | 40% |
| Passing #80 | 0% | 10% |
| Retained on #200 | 0% | 5% |

CONES:

(3-19-24)

1135

SP11 R35

Revise the *Standard Specifications* as follows:

Page 11-11, Article 1135-3 CONSTRUCTION METHODS, lines 19-20, delete the third sentence of the first paragraph, “Do not use cones in the upstream taper of lane or shoulder closures for multi-lane roadways.”.

PERMANENT SEEDING AND MULCHING:

(7-1-95)(Rev. 1-16-24)

1660

SP16 R02

The Department desires that permanent seeding and mulching be established on this project as soon as practical after slopes or portions of slopes have been graded. As an incentive to obtain an early stand of vegetation on this project, the Contractor's attention is called to the following:

For all permanent seeding and mulching that is satisfactorily completed in accordance with the requirements of Section 1660 in the *Standard Specifications* and within the following percentages of elapsed contract times, an additional payment will be made to the Contractor as an incentive additive. The incentive additive will be determined by multiplying the number of acres of seeding and mulching satisfactorily completed times the contract unit bid price per acre for Seeding and Mulching times the appropriate percentage additive.

| Percentage of Elapsed Contract Time | Percentage Additive |
|--|----------------------------|
| 0% - 30% | 30% |
| 30.01% - 50% | 15% |

Percentage of elapsed contract time is defined as the number of calendar days from the date of availability of the contract to the date the permanent seeding and mulching is acceptably completed divided by the total original contract time.

STANDARD SPECIAL PROVISION**AVAILABILITY OF FUNDS – TERMINATION OF CONTRACTS**

(5-20-08)(Rev. 1-16-24)

Z-2

General Statute 143C-6-11. (h) Highway Appropriation is hereby incorporated verbatim in this contract as follows:

(h) Amounts Encumbered. – Transportation project appropriations may be encumbered in the amount of allotments made to the Department of Transportation by the Director for the estimated payments for transportation project contract work to be performed in the appropriation fiscal year. The allotments shall be multiyear allotments and shall be based on estimated revenues and shall be subject to the maximum contract authority contained in *General Statute 143C-6-11(c)*. Payment for transportation project work performed pursuant to contract in any fiscal year other than the current fiscal year is subject to appropriations by the General Assembly. Transportation project contracts shall contain a schedule of estimated completion progress, and any acceleration of this progress shall be subject to the approval of the Department of Transportation provided funds are available. The State reserves the right to terminate or suspend any transportation project contract, and any transportation project contract shall be so terminated or suspended if funds will not be available for payment of the work to be performed during that fiscal year pursuant to the contract. In the event of termination of any contract, the contractor shall be given a written notice of termination at least 60 days before completion of scheduled work for which funds are available. In the event of termination, the contractor shall be paid for the work already performed in accordance with the contract specifications.

Payment will be made on any contract terminated pursuant to the special provision in accordance with Subarticle 108-13(D) of the *Standard Specifications*.

STANDARD SPECIAL PROVISION
NCDOT GENERAL SEED SPECIFICATION FOR SEED QUALITY

(5-17-11)

Z-3

Seed shall be sampled and tested by the North Carolina Department of Agriculture and Consumer Services, Seed Testing Laboratory. When said samples are collected, the vendor shall supply an independent laboratory report for each lot to be tested. Results from seed so sampled shall be final. Seed not meeting the specifications shall be rejected by the Department of Transportation and shall not be delivered to North Carolina Department of Transportation warehouses. If seed has been delivered it shall be available for pickup and replacement at the supplier's expense.

Any re-labeling required by the North Carolina Department of Agriculture and Consumer Services, Seed Testing Laboratory, that would cause the label to reflect as otherwise specified herein shall be rejected by the North Carolina Department of Transportation.

Seed shall be free from seeds of the noxious weeds Johnsongrass, Balloonvine, Jimsonweed, Witchweed, Itchgrass, Serrated Tussock, Showy Crotalaria, Smooth Crotalaria, Sicklepod, Sandbur, Wild Onion, and Wild Garlic. Seed shall not be labeled with the above weed species on the seed analysis label. Tolerances as applied by the Association of Official Seed Analysts will NOT be allowed for the above noxious weeds except for Wild Onion and Wild Garlic.

Tolerances established by the Association of Official Seed Analysts will generally be recognized. However, for the purpose of figuring pure live seed, the found pure seed and found germination percentages as reported by the North Carolina Department of Agriculture and Consumer Services, Seed Testing Laboratory will be used. Allowances, as established by the NCDOT, will be recognized for minimum pure live seed as listed on the following pages.

The specifications for restricted noxious weed seed refers to the number per pound as follows:

| <u>Restricted Noxious Weed</u> | <u>Limitations per Lb. Of Seed</u> | <u>Restricted Noxious Weed</u> | <u>Limitations per Lb. of Seed</u> |
|---------------------------------------|---|---------------------------------------|---|
| Blessed Thistle | 4 seeds | Cornflower (Ragged Robin) | 27 seeds |
| Cocklebur | 4 seeds | Texas Panicum | 27 seeds |
| Spurred Anoda | 4 seeds | Bracted Plantain | 54 seeds |
| Velvetleaf | 4 seeds | Buckhorn Plantain | 54 seeds |
| Morning-glory | 8 seeds | Broadleaf Dock | 54 seeds |
| Corn Cockle | 10 seeds | Curly Dock | 54 seeds |
| Wild Radish | 12 seeds | Dodder | 54 seeds |
| Purple Nutsedge | 27 seeds | Giant Foxtail | 54 seeds |
| Yellow Nutsedge | 27 seeds | Horsenettle | 54 seeds |
| Canada Thistle | 27 seeds | Quackgrass | 54 seeds |
| Field Bindweed | 27 seeds | Wild Mustard | 54 seeds |
| Hedge Bindweed | 27 seeds | | |

Seed of Pensacola Bahiagrass shall not contain more than 7% inert matter, Kentucky Bluegrass, Centipede and Fine or Hard Fescue shall not contain more than 5% inert matter whereas a maximum of 2% inert matter will be allowed on all other kinds of seed. In addition, all seed

shall not contain more than 2% other crop seed nor more than 1% total weed seed. The germination rate as tested by the North Carolina Department of Agriculture shall not fall below 70%, which includes both dormant and hard seed. Seed shall be labeled with not more than 7%, 5% or 2% inert matter (according to above specifications), 2% other crop seed and 1% total weed seed.

Exceptions may be made for minimum pure live seed allowances when cases of seed variety shortages are verified. Pure live seed percentages will be applied in a verified shortage situation. Those purchase orders of deficient seed lots will be credited with the percentage that the seed is deficient.

FURTHER SPECIFICATIONS FOR EACH SEED GROUP ARE GIVEN BELOW:

Minimum 85% pure live seed; maximum 1% total weed seed; maximum 2% total other crop seed; maximum 144 restricted noxious weed seed per pound. Seed less than 83% pure live seed will not be approved.

Sericea Lespedeza
Oats (seeds)

Minimum 80% pure live seed; maximum 1% total weed seed; maximum 2% total other crop; maximum 144 restricted noxious weed seed per pound. Seed less than 78% pure live seed will not be approved.

| | |
|--------------------------------------|----------------------------|
| Tall Fescue (all approved varieties) | Bermudagrass |
| Kobe Lespedeza | Browntop Millet |
| Korean Lespedeza | German Millet – Strain R |
| Weeping Lovegrass | Clover – Red/White/Crimson |
| Carpetgrass | |

Minimum 78% pure live seed; maximum 1% total weed seed; maximum 2% total other crop seed; maximum 144 restricted noxious weed seed per pound. Seed less than 76% pure live seed will not be approved.

Common or Sweet Sundangrass

Minimum 76% pure live seed; maximum 1% total weed seed; maximum 2% total other crop seed; maximum 144 restricted noxious weed seed per pound. Seed less than 74% pure live seed will not be approved.

Rye (grain; all varieties)
Kentucky Bluegrass (all approved varieties)
Hard Fescue (all approved varieties)
Shrub (bicolor) Lespedeza

Minimum 70% pure live seed; maximum 1% total weed seed; maximum 2% total other crop seed; maximum 144 noxious weed seed per pound. Seed less than 70% pure live seed will not be approved.

| | |
|----------------------|-------------------|
| Centipedegrass | Japanese Millet |
| Crownvetch | Reed Canary Grass |
| Pensacola Bahiagrass | Zoysia |

Creeping Red Fescue

Minimum 70% pure live seed; maximum 1% total weed seed; maximum 2% total other crop seed; maximum 5% inert matter; maximum 144 restricted noxious weed seed per pound.

Barnyard Grass
Big Bluestem
Little Bluestem
Bristly Locust
Birdsfoot Trefoil
Indiangrass
Orchardgrass
Switchgrass
Yellow Blossom Sweet Clover

STANDARD SPECIAL PROVISION
ERRATA

(1-16-24)

Z-4

Revise the *2024 Standard Specifications* as follows:

Division 3

Page 3-5, Article 305-2 MATERIALS, after line 16, replace " 1032-3(A)(7)" with "1032-3" and add the item "Galvanized Corrugated Steel Pipe" with Section "1032-3".

Page 3-6, Article 310-2 MATERIALS, after line 9, add the item "Galvanized Corrugated Steel Pipe" with Section "1032-3".

Division 9

Page 9-17, Article 904-4 MEASUREMENT AND PAYMENT, prior to line 1, replace " Sign Erection, Relocate Type (Ground Mounted)" with "Sign Erection, Relocate Type ___ (Ground Mounted)".

Division 10

Page 10-51, Article 1024-4 WATER, prior to line 1, delete the "unpopulated blank row" in Table 1024-2 between "Time of set, deviation from control" and "Chloride Ion Content, Max.".

Page 10-170, Subarticle 1081-1(C) Requirements, line 4, replace "maximum" with "minimum".

Division 11

Page 11-15, Article 1160-4 MEASUREMENT AND PAYMENT, line 24, replace "Where barrier units are moved more than one" with "Where barrier units are moved more than once".

Division 15

Page 15-10, Article 1515-4 MEASUREMENT AND PAYMENT, lines 11, replace " All piping" with "All labor, the manhole, other materials, excavation, backfilling, piping".

Division 16

Page 16-14, Article 1633-5 MEASUREMENT AND PAYMENT, line 20-24 and prior to line 25, delete and replace with the following " *Flocculant* will be measured and paid in accordance with Article 1642-5 applied to the temporary rock silt checks."

Page 16-3, Article 1609-2 MATERIALS, after line 26, replace "Type 4" with "Type 4a".

Page 16-25, Article 1644-2 MATERIALS, after line 22, replace "Type 4" with "Type 4a".

STANDARD SPECIAL PROVISION**PLANT AND PEST QUARANTINES****(Imported Fire Ant, Gypsy Moth, Witchweed, Emerald Ash Borer, Guava Root Knot Nematode, And Other Noxious Weeds)**

(3-18-03) (Rev. 5-21-19)

Z-04a

Within Quarantined Area

This project may be within a county regulated for plant and/or pests. If the project or any part of the Contractor's operations is located within a quarantined area, thoroughly clean all equipment prior to moving out of the quarantined area. Comply with federal/state regulations by obtaining a certificate or limited permit for any regulated article moving from the quarantined area.

Originating in a Quarantined County

Obtain a certificate or limited permit issued by the N.C. Department of Agriculture/United States Department of Agriculture. Have the certificate or limited permit accompany the article when it arrives at the project site.

Contact

Contact the N.C. Department of Agriculture/United States Department of Agriculture at 1-800-206-9333, 919-707-3730, or <https://www.ncagr.gov/plantindustry/Plant/quaran/table2.htm> to determine those specific project sites located in the quarantined area or for any regulated article used on this project originating in a quarantined county.

Regulated Articles Include

1. Soil, sand, gravel, compost, peat, humus, muck, and decomposed manure, separately or with other articles. This includes movement of articles listed above that may be associated with cut/waste, ditch pulling, and shoulder cutting.
2. Plants with roots including grass sod.
3. Plant crowns and roots.
4. Bulbs, corms, rhizomes, and tubers of ornamental plants.
5. Hay, straw, fodder, and plant litter of any kind.
6. Clearing and grubbing debris.
7. Used agricultural cultivating and harvesting equipment.
8. Used earth-moving equipment.
9. Any other products, articles, or means of conveyance, of any character, if determined by an inspector to present a hazard of spreading imported fire ant, gypsy moth, witchweed, emerald ash borer, guava root knot nematode, or other noxious weeds.

STANDARD SPECIAL PROVISION

MINIMUM WAGES

(7-21-09)

Z-5

FEDERAL: The Fair Labor Standards Act provides that with certain exceptions every employer shall pay wages at the rate of not less than SEVEN DOLLARS AND TWENTY FIVE CENTS (\$7.25) per hour.

STATE: The North Carolina Minimum Wage Act provides that every employer shall pay to each of his employees, wages at a rate of not less than SEVEN DOLLARS AND TWENTY FIVE CENTS (\$7.25) per hour.

The minimum wage paid to all skilled labor employed on this contract shall be SEVEN DOLLARS AND TWENTY FIVE CENTS (\$7.25) per hour.

The minimum wage paid to all intermediate labor employed on this contract shall be SEVEN DOLLARS AND TWENTY FIVE CENTS (\$7.25) per hour.

The minimum wage paid to all unskilled labor on this contract shall be SEVEN DOLLARS AND TWENTY FIVE CENTS (\$7.25) per hour.

This determination of the intent of the application of this act to the contract on this project is the responsibility of the Contractor.

The Contractor shall have no claim against the Department of Transportation for any changes in the minimum wage laws, Federal or State. It is the responsibility of the Contractor to keep fully informed of all Federal and State Laws affecting his contract.

STANDARD SPECIAL PROVISION**TITLE VI AND NONDISCRIMINATION:**

(6-28-77)(Rev 1/16/2024)

Z-6

The North Carolina Department of Transportation is committed to carrying out the U.S. Department of Transportation's policy of ensuring nondiscrimination in the award and administration of contracts.

The provisions of this section related to United States Department of Transportation (US DOT) Order 1050.2A, Title 49 Code of Federal Regulations (CFR) part 21, 23 United States Code (U.S.C.) 140 and 23 CFR part 200 (or 49 CFR 303, 49 U.S.C. 5332 or 49 U.S.C. 47123) are applicable to all North Carolina Department of Transportation (NCDOT) contracts and to all related subcontracts, material supply, engineering, architectural and other service contracts, regardless of dollar amount. Any Federal provision that is specifically required not specifically set forth is hereby incorporated by reference.

(1) Title VI Assurances (USDOT Order 1050.2A, Appendix A)

During the performance of this contract, the contractor, for itself, its assignees, and successors in interest (hereinafter referred to as the "contractor") agrees as follows:

(a) Compliance with Regulations

The contractor (hereinafter includes consultants) shall comply with the Acts and the Regulations relative to Nondiscrimination in Federally-assisted programs of the U.S. Department of Transportation, Federal Highway Administration (FHWA), as they may be amended from time to time, which are herein incorporated by reference and made a part of this contract.

(b) Nondiscrimination

The contractor, with regard to the work performed by it during the contract, shall not discriminate on the grounds of race, color, or national origin in the selection and retention of subcontractors, including procurements of materials and leases of equipment. The contractor shall not participate directly or indirectly in the discrimination prohibited by the Acts and the Regulations, including employment practices when the contract covers any activity, project, or program set forth in Appendix B of 49 CFR Part 21.

(c) Solicitations for Subcontractors, Including Procurements of Materials and Equipment

In all solicitations, either by competitive bidding, or negotiation made by the contractor for work to be performed under a subcontract, including procurements of materials, or leases of equipment, each potential subcontractor or supplier shall be notified by the contractor of the contractor's obligations under this contract and the Acts and the Regulations relative to Nondiscrimination on the grounds of race, color, or national origin.

(d) Information and Reports

The contractor shall provide all information and reports required by the Acts, the Regulations, and directives issued pursuant thereto and shall permit access to its

books, records, accounts, other sources of information, and its facilities as may be determined by the Recipient or the FHWA to be pertinent to ascertain compliance with such Acts, Regulations, and instructions. Where any information required of a contractor is in the exclusive possession of another who fails or refuses to furnish the information, the contractor shall so certify to the Recipient or the FHWA, as appropriate, and shall set forth what efforts it has made to obtain the information.

(e) Sanctions for Noncompliance:

In the event of a contractor's noncompliance with the Non-discrimination provisions of this contract, the Recipient will impose such contract sanctions as it and/or the FHWA may determine to be appropriate, including, but not limited to:

- (i) Withholding payments to the contractor under the contract until the contractor complies; and/or
- (ii) Cancelling, terminating, or suspending a contract, in whole or in part.

(f) Incorporation of Provisions

The contractor shall include the provisions of paragraphs (a) through (f) in every subcontract, including procurements of materials and leases of equipment, unless exempt by the Acts, the Regulations and directives issued pursuant thereto. The contractor shall take action with respect to any subcontract or procurement as the Recipient or the FHWA may direct as a means of enforcing such provisions including sanctions for noncompliance. Provided, that if the contractor becomes involved in, or is threatened with litigation by a subcontractor, or supplier because of such direction, the contractor may request the Recipient to enter into any litigation to protect the interests of the Recipient. In addition, the contractor may request the United States to enter into the litigation to protect the interests of the United States.

(2) Title VI Nondiscrimination Program (23 CFR 200.5(p))

The North Carolina Department of Transportation (NCDOT) has assured the USDOT that, as a condition to receiving federal financial assistance, NCDOT will comply with Title VI of the Civil Rights Act of 1964 and all requirements imposed by Title 49 CFR part 21 and related nondiscrimination authorities to ensure that no person shall, on the ground of race, color, national origin, limited English proficiency, sex, age, or disability (including religion/creed or income-level, where applicable), be excluded from participation in, be denied the benefits of, or be subjected to discrimination under any programs, activities, or services conducted or funded by NCDOT. Contractors and other organizations under contract or agreement with NCDOT must also comply with Title VI and related authorities, therefore:

- (a) During the performance of this contract or agreement, contractors (e.g., subcontractors, consultants, vendors, prime contractors) are responsible for complying with NCDOT's Title VI Program. Contractors are not required to prepare or submit Title VI Programs. To comply with this section, the prime contractor shall:
 1. Post NCDOT's Notice of Nondiscrimination and the Contractor's own Equal Employment Opportunity (EEO) Policy in conspicuous locations accessible to all employees, applicants and subcontractors on the jobsite.

2. Physically incorporate the required Title VI clauses into all subcontracts on federally-assisted and state-funded NCDOT projects, and ensure inclusion by subcontractors into all lower-tier subcontracts.
 3. Required Solicitation Language. The Contractor shall include the following notification in all solicitations for bids and requests for work or material, regardless of funding source:

“The North Carolina Department of Transportation, in accordance with the provisions of Title VI of the Civil Rights Act of 1964 (78 Stat. 252, 42 U.S.C. §§ 2000d to 2000d-4) and the Regulations, hereby notifies all bidders that it will affirmatively ensure that any contract entered into pursuant to this advertisement, disadvantaged business enterprises will be afforded full and fair opportunity to submit bids in response to this invitation and will not be discriminated against on the grounds of race, color, or national origin in consideration for an award. In accordance with other related nondiscrimination authorities, bidders and contractors will also not be discriminated against on the grounds of sex, age, disability, low-income level, creed/religion, or limited English proficiency in consideration for an award.”
 4. Physically incorporate the FHWA-1273, in its entirety, into all subcontracts and subsequent lower tier subcontracts on Federal-aid highway construction contracts only.
 5. Provide language assistance services (i.e., written translation and oral interpretation), free of charge, to LEP employees and applicants. Contact NCDOT OCR for further assistance, if needed.
 6. For assistance with these Title VI requirements, contact the NCDOT Title VI Nondiscrimination Program at 1-800-522-0453.
- (b) Subrecipients (e.g. cities, counties, LGAs, planning organizations) may be required to prepare and submit a Title VI Plan to NCDOT, including Title VI Assurances and/or agreements. Subrecipients must also ensure compliance by their contractors and subrecipients with Title VI. (23 CFR 200.9(b)(7))
- (c) If reviewed or investigated by NCDOT, the contractor or subrecipient agrees to take affirmative action to correct any deficiencies found within a reasonable time period, not to exceed 90 calendar days, unless additional time is granted by NCDOT. (23 CFR 200.9(b)(15))
- (d) The Contractor is responsible for notifying subcontractors of NCDOT’s External Discrimination Complaints Process.
1. Applicability

Title VI and related laws protect participants and beneficiaries (e.g., members of the public and contractors) from discrimination by NCDOT employees, subrecipients and contractors, regardless of funding source.

2. Eligibility

Any person—or class of persons—who believes he/she has been subjected to discrimination based on race, color, national origin, Limited English Proficiency (LEP), sex, age, or disability (and religion in the context of employment, aviation, or transit) may file a written complaint. The law also prohibits intimidation or retaliation of any sort.

3. Time Limits and Filing Options

Complaints may be filed by the affected individual(s) or a representative and must be filed no later than 180 calendar days after the following:

- (i) The date of the alleged act of discrimination; or
- (ii) The date when the person(s) became aware of the alleged discrimination; or
- (iii) Where there has been a continuing course of conduct, the date on which that conduct was discontinued or the latest instance of the conduct.

Title VI and related discrimination complaints may be submitted to the following entities:

- North Carolina Department of Transportation, Office of Civil Rights, Title VI Program, 1511 Mail Service Center, Raleigh, NC 27699-1511; toll free 1-800-522-0453
- Federal Highway Administration, North Carolina Division Office, 310 New Bern Avenue, Suite 410, Raleigh, NC 27601, 919-747-7010
- US Department of Transportation, Departmental Office of Civil Rights, External Civil Rights Programs Division, 1200 New Jersey Avenue, SE, Washington, DC 20590; 202-366-4070

4. Format for Complaints

Complaints must be in writing and signed by the complainant(s) or a representative, and include the complainant's name, address, and telephone number. Complaints received by fax or e-mail will be acknowledged and processed. Allegations received by telephone will be reduced to writing and provided to the complainant for confirmation or revision before processing. Complaints will be accepted in other languages, including Braille.

5. Discrimination Complaint Form

Contact NCDOT Civil Rights to receive a full copy of the Discrimination Complaint Form and procedures.

6. Complaint Basis

Allegations must be based on issues involving race, color, national origin (LEP), sex, age, disability, or religion (in the context of employment, aviation or transit). "Basis" refers to the complainant's membership in a protected group category.

| TABLE 103-1 COMPLAINT BASIS | | | |
|---|--|--|--|
| Protected Categories | Definition | Examples | Applicable Nondiscrimination Authorities |
| Race and Ethnicity | An individual belonging to one of the accepted racial groups; or the perception, based usually on physical characteristics that a person is a member of a racial group | Black/African American, Hispanic/Latino, Asian, American Indian/Alaska Native, Native Hawaiian/Pacific Islander, White | Title VI of the Civil Rights Act of 1964; 49 CFR Part 21; 23 CFR 200; 49 U.S.C. 5332(b); 49 U.S.C. 47123. (<i>Executive Order 13166</i>) |
| Color | Color of skin, including shade of skin within a racial group | Black, White, brown, yellow, etc. | |
| National Origin (<i>Limited English Proficiency</i>) | Place of birth. Citizenship is not a factor. (<i>Discrimination based on language or a person's accent is also covered</i>) | Mexican, Cuban, Japanese, Vietnamese, Chinese | |
| Sex | Gender. The sex of an individual. <i>Note: Sex under this program does not include sexual orientation.</i> | Women and Men | 1973 Federal-Aid Highway Act; 49 U.S.C. 5332(b); 49 U.S.C. 47123. |
| Age | Persons of any age | 21-year-old person | Age Discrimination Act of 1975 49 U.S.C. 5332(b); 49 U.S.C. 47123. |
| Disability | Physical or mental impairment, permanent or temporary, or perceived. | Blind, alcoholic, para-amputee, epileptic, diabetic, arthritic | Section 504 of the Rehabilitation Act of 1973; Americans with Disabilities Act of 1990 |
| Religion (in the context of employment) (<i>Religion/ Creed in all aspects of any aviation or transit-related construction</i>) | An individual belonging to a religious group; or the perception, based on distinguishable characteristics that a person is a member of a religious group. In practice, actions taken as a result of the moral and ethical beliefs as to what is right and wrong, which are sincerely held with the strength of traditional religious views. <i>Note: Does not have to be associated with a recognized religious group or church; if an individual sincerely holds to the belief, it is a protected religious practice.</i> | Muslim, Christian, Sikh, Hindu, etc. | Title VII of the Civil Rights Act of 1964; 23 CFR 230; FHWA-1273 Required Contract Provisions. (<i>49 U.S.C. 5332(b); 49 U.S.C. 47123</i>) |

(3) Pertinent Nondiscrimination Authorities

During the performance of this contract, the contractor, for itself, its assignees, and successors in interest agrees to comply with the following non-discrimination statutes and authorities, including, but not limited to:

- (a) Title VI of the Civil Rights Act of 1964 (42 U.S.C. § 2000d et seq., 78 stat. 252), (prohibits discrimination on the basis of race, color, national origin); and 49 CFR Part 21.

- (b) The Uniform Relocation Assistance and Real Property Acquisition Policies Act of 1970, (42 U.S.C. § 4601), (prohibits unfair treatment of persons displaced or whose property has been acquired because of Federal or Federal-aid programs and projects);
- (c) Federal-Aid Highway Act of 1973, (23 U.S.C. § 324 et seq.), (prohibits discrimination on the basis of sex);
- (d) Section 504 of the Rehabilitation Act of 1973, (29 U.S.C. § 794 et seq.), as amended, (prohibits discrimination on the basis of disability) and 49 CFR Part 27;
- (e) The Age Discrimination Act of 1975, as amended, (42 U.S.C. § 6101 et seq.), (prohibits discrimination on the basis of age);
- (f) Airport and Airway Improvement Act of 1982, (49 USC § 471, Section 47123), as amended, (prohibits discrimination based on race, creed, color, national origin, or sex);
- (g) The Civil Rights Restoration Act of 1987, (PL 100-209), (Broadened the scope, coverage and applicability of Title VI of the Civil Rights Act of 1964, The Age Discrimination Act of 1975 and Section 504 of the Rehabilitation Act of 1973, by expanding the definition of the terms "programs or activities" to include all of the programs or activities of the Federal-aid recipients, sub-recipients and contractors, whether such programs or activities are Federally funded or not);
- (h) Titles II and III of the Americans with Disabilities Act, which prohibit discrimination on the basis of disability in the operation of public entities, public and private transportation systems, places of public accommodation, and certain testing entities (42 U.S.C. §§ 12131-12189) as implemented by Department of Transportation regulations at 49 C.F.R. parts 37 and 38;
- (i) The Federal Aviation Administration's Nondiscrimination statute (49 U.S.C. § 47123) (prohibits discrimination on the basis of race, color, national origin, and sex);
- (j) Executive Order 12898, Federal Actions to Address Environmental Justice in Minority Populations and Low-Income Populations, which ensures Nondiscrimination against minority populations by discouraging programs, policies, and activities with disproportionately high and adverse human health or environmental effects on minority and low-income populations;
- (k) Executive Order 13166, Improving Access to Services for Persons with Limited English Proficiency, and resulting agency guidance, national origin discrimination includes discrimination because of Limited English proficiency (LEP). To ensure compliance with Title VI, you must take reasonable steps to ensure that LEP persons have meaningful access to your programs (70 Fed. Reg. at 74087 to 74100);
- (l) Title IX of the Education Amendments of 1972, as amended, which prohibits you from discriminating because of sex in education programs or activities (20 U.S.C. 1681 et seq).
- (m) Title VII of the Civil Rights Act of 1964 (42 U.S.C. § 2000e et seq., Pub. L. 88-352), (prohibits employment discrimination on the basis of race, color, religion, sex, or national origin).

(4) Additional Title VI Assurances

***The following Title VI Assurances (Appendices B, C and D) shall apply, as applicable*

- (a) Clauses for Deeds Transferring United States Property (1050.2A, Appendix B)

The following clauses will be included in deeds effecting or recording the transfer of real property, structures, or improvements thereon, or granting interest therein from the United States pursuant to the provisions of Assurance 4.

NOW, THEREFORE, the U.S. Department of Transportation as authorized by law and upon the condition that the North Carolina Department of Transportation (NCDOT) will accept title to the lands and maintain the project constructed thereon in accordance with the North Carolina General Assembly, the Regulations for the Administration of the Federal-Aid Highway Program, and the policies and procedures prescribed by the Federal Highway Administration of the U.S. Department of Transportation in accordance and in compliance with all requirements imposed by Title 49, Code of Federal Regulations, U.S. Department of Transportation, Subtitle A, Office of the Secretary, Part 21, Nondiscrimination in Federally-assisted programs of the U.S. Department of Transportation pertaining to and effectuating the provisions of Title VI of the Civil Rights Act of 1964 (78 Stat. 252; 42 U.S.C. § 2000d to 2000d-4), does hereby remise, release, quitclaim and convey unto the NCDOT all the right, title and interest of the U.S. Department of Transportation in and to said lands described in Exhibit A attached hereto and made a part hereof.

(HABENDUM CLAUSE)

TO HAVE AND TO HOLD said lands and interests therein unto the North Carolina Department of Transportation (NCDOT) and its successors forever, subject, however, to the covenants, conditions, restrictions and reservations herein contained as follows, which will remain in effect for the period during which the real property or structures are used for a purpose for which Federal financial assistance is extended or for another purpose involving the provision of similar services or benefits and will be binding on the NCDOT, its successors and assigns.

The NCDOT, in consideration of the conveyance of said lands and interests in lands, does hereby covenant and agree as a covenant running with the land for itself, its successors and assigns, that (1) no person will on the grounds of race, color, or national origin, be excluded from participation in, be denied the benefits of, or be otherwise subjected to discrimination with regard to any facility located wholly or in part on, over, or under such lands hereby conveyed [,] [and]* (2) that the NCDOT will use the lands and interests in lands and interests in lands so conveyed, in compliance with all requirements imposed by or pursuant to Title 49, Code of Federal Regulations, U.S. Department of Transportation, Subtitle A, Office of the Secretary, Part 21, Non-discrimination in Federally-assisted programs of the U.S. Department of Transportation, Effectuation of Title VI of the Civil Rights Act of 1964, and as said Regulations and Acts may be amended [, and (3) that in the event of breach of any of the above-mentioned nondiscrimination conditions, the Department will have a right to enter or re-enter said lands and facilities on said land, and that above described land and facilities will thereon revert to and vest in and become the absolute property of the U.S. Department of Transportation and its assigns as such interest existed prior to this instruction].*

(*Reverter clause and related language to be used only when it is determined that such a clause is necessary in order to make clear the purpose of Title VI.)

(b) Clauses for Transfer of Real Property Acquired or Improved Under the Activity, Facility, or Program (1050.2A, Appendix C)

The following clauses will be included in deeds, licenses, leases, permits, or similar instruments entered into by the North Carolina Department of Transportation (NCDOT) pursuant to the provisions of Assurance 7(a):

1. The (grantee, lessee, permittee, etc. as appropriate) for himself/herself, his/her heirs, personal representatives, successors in interest, and assigns, as a part of the consideration hereof, does hereby covenant and agree [in the case of deeds and leases add "as a covenant running with the land"] that:
 - (i.) In the event facilities are constructed, maintained, or otherwise operated on the property described in this (deed, license, lease, permit, etc.) for a purpose for which a U.S. Department of Transportation activity, facility, or program is extended or for another purpose involving the provision of similar services or benefits, the (grantee, licensee, lessee, permittee, etc.) will maintain and operate such facilities and services in compliance with all requirements imposed by the Acts and Regulations (as may be amended) such that no person on the grounds of race, color, or national origin, will be excluded from participation in, denied the benefits of, or be otherwise subjected to discrimination in the use of said facilities.
2. With respect to licenses, leases, permits, etc., in the event of breach of any of the above Nondiscrimination covenants, the NCDOT will have the right to terminate the (lease, license, permit, etc.) and to enter, re-enter, and repossess said lands and facilities thereon, and hold the same as if the (lease, license, permit, etc.) had never been made or issued. *
3. With respect to a deed, in the event of breach of any of the above Nondiscrimination covenants, the NCDOT will have the right to enter or re-enter the lands and facilities thereon, and the above described lands and facilities will there upon revert to and vest in and become the absolute property of the NCDOT and its assigns. *

(*Reverter clause and related language to be used only when it is determined that such a clause is necessary to make clear the purpose of Title VI.)

(c) Clauses for Construction/Use/Access to Real Property Acquired Under the Activity, Facility or Program (1050.2A, Appendix D)

The following clauses will be included in deeds, licenses, permits, or similar instruments/ agreements entered into by the North Carolina Department of Transportation (NCDOT) pursuant to the provisions of Assurance 7(b):

1. The (grantee, licensee, permittee, etc., as appropriate) for himself/herself, his/her heirs, personal representatives, successors in interest, and assigns, as a part of the consideration hereof, does hereby covenant and agree (in the case of deeds and leases add, "as a covenant running with the land") that (1) no person on the ground of race, color, or national origin, will be excluded from participation in, denied the benefits of, or be otherwise subjected to discrimination in the use of said facilities, (2) that in the construction of any improvements on, over, or under such land, and the furnishing of services thereon, no person on the ground of race, color, or national origin, will be excluded from participation in, denied the benefits of, or otherwise be subjected to discrimination, (3) that the (grantee, licensee, lessee, permittee, etc.) will use the premises in compliance with all other requirements imposed by or pursuant to the Acts and Regulations, as amended, set forth in this Assurance.
2. With respect to (licenses, leases, permits, etc.), in the event of breach of any of the above Non-discrimination covenants, the NCDOT will have the right to terminate the (license, permit, etc., as appropriate) and to enter or re-enter and repossess said land and the facilities thereon, and hold the same as if said (license, permit, etc., as appropriate) had never been made or issued. *
3. With respect to deeds, in the event of breach of any of the above Nondiscrimination covenants, the NCDOT will there upon revert to and vest in and become the absolute property of the NCDOT and its assigns. *

(*Reverter clause and related language to be used only when it is determined that such a clause is necessary to make clear the purpose of Title VI.)

STANDARD SPECIAL PROVISION**ON-THE-JOB TRAINING**

(10-16-07) (Rev. 4-21-15)

Z-10

Description

The North Carolina Department of Transportation will administer a custom version of the Federal On-the-Job Training (OJT) Program, commonly referred to as the Alternate OJT Program. All contractors (existing and newcomers) will be automatically placed in the Alternate Program. Standard OJT requirements typically associated with individual projects will no longer be applied at the project level. Instead, these requirements will be applicable on an annual basis for each contractor administered by the OJT Program Manager.

On the Job Training shall meet the requirements of 23 CFR 230.107 (b), 23 USC – Section 140, this provision and the On-the-Job Training Program Manual.

The Alternate OJT Program will allow a contractor to train employees on Federal, State and privately funded projects located in North Carolina. However, priority shall be given to training employees on NCDOT Federal-Aid funded projects.

Minorities and Women

Developing, training and upgrading of minorities and women toward journeyman level status is a primary objective of this special training provision. Accordingly, the Contractor shall make every effort to enroll minority and women as trainees to the extent that such persons are available within a reasonable area of recruitment. This training commitment is not intended, and shall not be used, to discriminate against any applicant for training, whether a member of a minority group or not.

Assigning Training Goals

The Department, through the OJT Program Manager, will assign training goals for a calendar year based on the contractors' past three years' activity and the contractors' anticipated upcoming year's activity with the Department. At the beginning of each year, all contractors eligible will be contacted by the Department to determine the number of trainees that will be assigned for the upcoming calendar year. At that time the Contractor shall enter into an agreement with the Department to provide a self-imposed on-the-job training program for the calendar year. This agreement will include a specific number of annual training goals agreed to by both parties. The number of training assignments may range from 1 to 15 per contractor per calendar year. The Contractor shall sign an agreement to fulfill their annual goal for the year.\

Training Classifications

The Contractor shall provide on-the-job training aimed at developing full journeyman level workers in the construction craft/operator positions. Preference shall be given to providing training in the following skilled work classifications:

| | |
|---------------------|----------------------------------|
| Equipment Operators | Office Engineers |
| Truck Drivers | Estimators |
| Carpenters | Iron / Reinforcing Steel Workers |
| Concrete Finishers | Mechanics |
| Pipe Layers | Welders |

The Department has established common training classifications and their respective training requirements that may be used by the contractors. However, the classifications established are not all-inclusive. Where the training is oriented toward construction applications, training will be allowed in lower-level management positions such as office engineers and estimators. Contractors shall submit new classifications for specific job functions that their employees are performing. The Department will review and recommend for acceptance to FHWA the new classifications proposed by contractors, if applicable. New classifications shall meet the following requirements:

Proposed training classifications are reasonable and realistic based on the job skill classification needs, and

The number of training hours specified in the training classification is consistent with common practices and provides enough time for the trainee to obtain journeyman level status.

The Contractor may allow trainees to be trained by a subcontractor provided that the Contractor retains primary responsibility for meeting the training and this provision is made applicable to the subcontract. However, only the Contractor will receive credit towards the annual goal for the trainee.

Where feasible, 25 percent of apprentices or trainees in each occupation shall be in their first year of apprenticeship or training. The number of trainees shall be distributed among the work classifications on the basis of the contractor's needs and the availability of journeymen in the various classifications within a reasonable area of recruitment.

No employee shall be employed as a trainee in any classification in which they have successfully completed a training course leading to journeyman level status or in which they have been employed as a journeyman.

Records and Reports

The Contractor shall maintain enrollment, monthly and completion reports documenting company compliance under these contract documents. These documents and any other information as requested shall be submitted to the OJT Program Manager.

Upon completion and graduation of the program, the Contractor shall provide each trainee with a certification Certificate showing the type and length of training satisfactorily completed.

Trainee Interviews

All trainees enrolled in the program will receive an initial and Trainee/Post graduate interview conducted by the OJT program staff.

Trainee Wages

Contractors shall compensate trainees on a graduating pay scale based upon a percentage of the prevailing minimum journeyman wages (Davis-Bacon Act). Minimum pay shall be as follows:

| | |
|------------|---|
| 60 percent | of the journeyman wage for the first half of the training period |
| 75 percent | of the journeyman wage for the third quarter of the training period |
| 90 percent | of the journeyman wage for the last quarter of the training period |

In no instance shall a trainee be paid less than the local minimum wage. The Contractor shall adhere to the minimum hourly wage rate that will satisfy both the NC Department of Labor (NCDOL) and the Department.

Achieving or Failing to Meet Training Goals

The Contractor will be credited for each trainee employed by him on the contract work who is currently enrolled or becomes enrolled in an approved program and who receives training for at least 50 percent of the specific program requirement. Trainees will be allowed to be transferred between projects if required by the Contractor's scheduled workload to meet training goals.

If a contractor fails to attain their training assignments for the calendar year, they may be taken off the NCDOT's Bidders List.

Measurement and Payment

No compensation will be made for providing required training in accordance with these contract documents.

**PROJECT SPECIAL PROVISIONS
GEOENVIRONMENTAL**

CONTAMINATED SOIL (6/19/2023)

The Contractor's attention is directed to the fact that soil contaminated with petroleum hydrocarbon compounds exist within the project area. The known areas of contamination are indicated on corresponding plans sheets. Information relating to these contaminated areas, sample locations, and investigation reports will be available at the following web address by navigating to the correct letting year and month then selecting, "Plans and Proposals", "U-5757", "Individual Sheets/520 GeoEnvironmental":

<http://dotw-xfer01.dot.state.nc.us/dsplan/>

Petroleum contaminated soil may be encountered during any earthwork activities on the project. The Contractor shall only excavate those soils that the Engineer designates necessary to complete a particular task. The Engineer shall determine if soil is contaminated based on areas shown on the plans, petroleum odors, and unusual soil staining. Contaminated soil not required to be excavated is to remain in place and undisturbed. Undisturbed soil shall remain in place, whether contaminated or not. The Contractor shall transport all contaminated soil excavated from the project to a facility licensed to accept contaminated soil.

In the event that a stockpile is needed, the stockpile shall be created within the property boundaries of the source material and in accordance with the Diagram for Temporary Containment and Treatment of Petroleum-Contaminated Soil per North Carolina Department of Environmental Quality's (NCDEQ) Division of Waste Management UST Section GUIDELINES FOR EX SITU PETROLEUM CONTAMINATED SOIL REMEDIATION. If the volume of contaminated material exceeds available space on site, the Contractor shall obtain a permit from the NCDEQ UST Section's Regional Office for off-site temporary storage. The Contractor shall provide copies of disposal manifests completed per the disposal facilities requirements and weigh tickets to the Engineer.

Measurement and Payment:

The quantity of contaminated soil hauled and disposed of shall be the actual number of tons of material, which has been acceptably transported and weighed with certified scales as documented by disposal manifests and weigh tickets. The quantity of contaminated soil, measured as provided above, shall be paid for at the contract unit price per ton for "Hauling and Disposal of Petroleum Contaminated Soil".

The above price and payment shall be full compensation for all work covered by this section, including, but not limited to stockpiling, loading, transportation, weighing, laboratory testing, disposal, equipment, decontamination of equipment, labor, and personal protective equipment.

Payment shall be made under:

Pay Item

Hauling and Disposal of Petroleum Contaminated Soil

Pay Unit

Ton

DocuSigned by
Ethan J. Caldwell
E9A1CFAC49A2417
06/19/2023



TC-1

U-5757

Davidson County

WORK ZONE TRAFFIC CONTROL Project Special Provisions Table of Contents

| Special Provision | Page |
|--|------|
| ADA Compliant Pedestrian Traffic Control Devices | TC-2 |

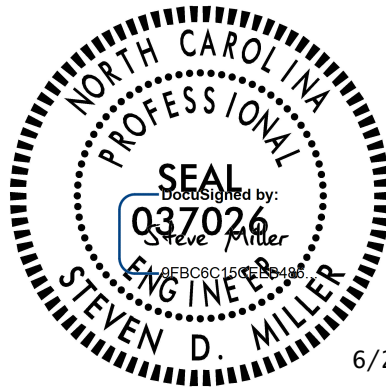

6/27/2024

TC-2

U-5757

Davidson County

ADA COMPLIANT PEDESTRIAN TRAFFIC CONTROL DEVICES:

(10/31/2017) (Rev. 6/3/2022)

Description

Furnish, install, and maintain all ADA compliant pedestrian traffic control devices for existing pedestrian facilities that are disrupted, closed, or relocated by planned work activities.

The ADA compliant pedestrian traffic control devices used to either close, redirect, divert or detour pedestrian traffic are Pedestrian Channelizing Devices and Audible Warning Devices.

Construction Methods

The ADA compliant pedestrian traffic control devices involved in the closing or redirecting of pedestrians as designated on the Transportation Management Plan (TMP) shall be manufactured and assembled in accordance with the requirements of the Americans with Disabilities Act (ADA) and be on the NCDOT approved products list.

Pedestrian Channelizing Devices shall be manufactured and assembled to be connected as to eliminate any gaps that allow pedestrians to stray from the channelizing path. Any Pedestrian Channelizing Devices used to close or block a pedestrian facility shall have a "SIDEWALK CLOSED" sign affixed to it and any audible warning devices, if designated on the TMP.

Audible Warning Devices shall be manufactured to include a locator tone activated by a motion sensor and have the ability to program a message for a duration of at least 1 minute. The motion sensor shall have the ability to detect pedestrians a minimum of 10' away. The voice module may be automatic or it may be push button activated. If push button activated, it shall be mounted at a height of approximately 3.5 feet, but no more than 4 feet, above the pedestrian facility.

Measurement and Payment

Pedestrian Channelizing Devices will be measured and paid as the maximum number of linear feet of *Pedestrian Channelizing Devices* furnished, acceptably placed, and in use at any one time during the life of the project.

No direct payment will be made for any sign affixed to a pedestrian channelizing device. Signs mounted to pedestrian channelizing devices will be considered incidental to the device.

Audible Warning Devices will be measured and paid as the maximum number of *Audible Warning Devices* furnished, acceptably installed, and in use at any one time during the life of the project.

TC-3

U-5757

Davidson County

Relocation, replacement, repair, maintenance, or disposal of *Pedestrian Channelizing Devices* and *Audible Warning Devices* will be incidental to the pay item.

Payment will be made under:

| Pay Item | Pay Unit |
|---------------------------------|-----------------|
| Pedestrian Channelizing Devices | Linear Foot |
| Audible Warning Devices | Each |

Project: U-5757

UC-1

County: Davidson

PROJECT SPECIAL PROVISIONS
Utility Construction

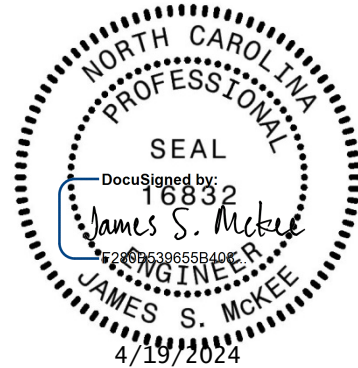

**DOCUMENT NOT CONSIDERED FINAL
UNLESS ALL SIGNATURES COMPLETED**

Where brand names and model numbers are specified in these Special Provisions or in the plans, the cited examples are used only to denote the quality standard of product desired and do not restrict bidders to a specific brand, make, or manufacturer. They are provided to set forth the general style, type, character, and quality of the product desired. Equivalent products will be acceptable.

The utility owner is the City of Lexington. For work involving Lexington’s facilities, the Contractor shall contact the City of Lexington Utilities Department at (336) 248-3930 during normal business hours, or (336) 248-2337 outside normal business hours.

Representatives from the City of Lexington shall be provided the opportunity to witness all tests performed on their facilities. Test results shall be provided to the City of Lexington for any tests involving their facilities.

The provisions contained within these Utilities Construction Project Special Provisions modify the *Standard Specifications* only for materials used and work performed constructing water or sewer facilities owned by the City of Lexington.

PROJECT SPECIAL PROVISIONS**Utilities by Others**

| |
|--|
| TranSystems 1 Glenwood Avenue Suite 600 Raleigh, NC 27603 |
|--|

General:

The following utility companies have facilities that will conflict with the construction of this project:

- A) City of Lexington – Power (Distribution)
- B) City of Lexington – Power (Transmission)
- C) Duke Energy – Power (Distribution)
- D) City of Lexington – Gas (Distribution)
- E) Verizon – Communications
- F) Windstream – Communications
- G) Charter - Communications

The conflicting facilities of these concerns will be adjusted prior to the Date of Availability, unless otherwise noted and are therefore listed in these special provisions for the benefit of the Contractor. All utility work listed herein will be done by the utility owners. All utilities are shown on the plans from the best available information.

The Contractor's attention is directed to Article 105-8 of the 2024 Standard Specifications.

Utilities Requiring Adjustment:

Utility relocations are shown on the Utilities by Others Plans.

- A) City of Lexington – Power (Distribution)
 - 1) The City of Lexington will relocate their facilities by March 1, 2025.
 - 2) Contact person for the City of Lexington is Jeff Jones at (336)243-2489 x 3269.
- B) City of Lexington – Power (Transmission)
 - 1) The City of Lexington will relocate their facilities by March 1, 2025.
 - 2) Contact person for the City of Lexington is Jeff Jones at (336)-243-2489 x 3269.
- C) Duke Energy – Power (Distribution)
 - 1) Duke Energy will relocate their facilities by the Date of Availability.
 - 2) Contact person for Duke Energy is Jason Hugendubler at (336)517-2988.
- D) City of Lexington – Gas (Distribution)
 - 1) The City of Lexington will relocate their facilities by the Date of Availability.
 - 2) Contact person for the City of Lexington is Andy Thomas at (336)248-3945.

PROJECT SPECIAL PROVISIONS

Utilities by Others

- E) Verizon – Communications
 - 1) Verizon will relocate facilities by the Date of Availability.
 - 2) Contact person for Verizon is Leon Jones at (336)289-8847.
- F) Windstream – Communications
 - 1) Windstream will relocate their facilities by March 1, 2025.
 - 2) Contact person for Windstream is Gary Radford at (980)621-4730.
- G) Charter – Communications
 - 1) Charter will relocate their facilities by March 1, 2025.
 - 2) Contact person for Charter is Scottie Chilton at (336)451-9092.

**Project Special Provisions
Erosion Control**

STABILIZATION REQUIREMENTS:

(4-30-2019)

Stabilization for this project shall comply with the time frame guidelines as specified by the NCG-010000 general construction permit effective April 1, 2019 issued by the North Carolina Department of Environmental Quality Division of Water Resources. Temporary or permanent ground cover stabilization shall occur within 7 calendar days from the last land-disturbing activity, with the following exceptions in which temporary or permanent ground cover shall be provided in 14 calendar days from the last land-disturbing activity:

- Slopes between 2:1 and 3:1, with a slope length of 10 ft. or less
- Slopes 3:1 or flatter, with a slope of length of 50 ft. or less
- Slopes 4:1 or flatter

The stabilization timeframe for High Quality Water (HQW) Zones shall be 7 calendar days with no exceptions for slope grades or lengths. High Quality Water Zones (HQW) Zones are defined by North Carolina Administrative Code 15A NCAC 04A.0105 (25). Temporary and permanent ground cover stabilization shall be achieved in accordance with the provisions in this contract and as directed.

SEEDING AND MULCHING:

(West)

The kinds of seed and fertilizer, and the rates of application of seed, fertilizer, and limestone, shall be as stated below. During periods of overlapping dates, the kind of seed to be used shall be determined. All rates are in pounds per acre.

Shoulder and Median Areas

August 1 - June 1

| | |
|-------|--------------------|
| 20# | Kentucky Bluegrass |
| 75# | Hard Fescue |
| 25# | Rye Grain |
| 500# | Fertilizer |
| 4000# | Limestone |

May 1 - September 1

| | |
|-------|---------------------------|
| 20# | Kentucky Bluegrass |
| 75# | Hard Fescue |
| 10# | German or Browntop Millet |
| 500# | Fertilizer |
| 4000# | Limestone |

Areas Beyond the Mowing Pattern, Waste and Borrow Areas:

August 1 - June 1

| | |
|------|--------------------|
| 100# | Tall Fescue |
| 15# | Kentucky Bluegrass |
| 30# | Hard Fescue |
| 25# | Rye Grain |
| 500# | Fertilizer |

May 1 - September 1

| | |
|------|---------------------------|
| 100# | Tall Fescue |
| 15# | Kentucky Bluegrass |
| 30# | Hard Fescue |
| 10# | German or Browntop Millet |
| 500# | Fertilizer |

4000# Limestone 4000# Limestone

Approved Tall Fescue Cultivars

| | | | |
|----------------------------|-----------------|-----------------|--------------------|
| 06 Dust | Escalade | Justice | Serengeti |
| 2 nd Millennium | Essential | Kalahari | Shelby |
| 3 rd Millennium | Evergreen 2 | Kitty Hawk 2000 | Sheridan |
| Apache III | Falcon IV | Legitimate | Signia |
| Avenger | Falcon NG | Lexington | Silver Hawk |
| Barlexas | Falcon V | LSD | Sliverstar |
| Barlexas II | Faith | Magellan | Shenandoah Elite |
| Bar Fa | Fat Cat | Matador | Sidewinder |
| Barrera | Festnova | Millennium SRP | Skyline |
| Barrington | Fidelity | Monet | Solara |
| Barrobusto | Finelawn Elite | Mustang 4 | Southern Choice II |
| Barvado | Finelawn Xpress | Ninja 2 | Speedway |
| Biltmore | Finesse II | Ol' Glory | Spyder LS |
| Bingo | Firebird | Olympic Gold | Sunset Gold |
| Bizem | Firecracker LS | Padre | Taccoa |
| Blackwatch | Firenza | Patagonia | Tanzania |
| Blade Runner II | Five Point | Pedigree | Trio |
| Bonsai | Focus | Picasso | Tahoe II |
| Braveheart | Forte | Piedmont | Talladega |
| Bravo | Garrison | Plantation | Tarheel |
| Bullseye | Gazelle II | Proseeds 5301 | Terrano |
| Cannavaro | Gold Medallion | Prospect | Titan ltd |
| Catalyst | Grande 3 | Pure Gold | Titanium LS |
| Cayenne | Greenbrooks | Quest | Tracer |
| Cessane Rz | Greenkeeper | Raptor II | Traverse SRP |
| Chipper | Gremlin | Rebel Exeda | Tulsa Time |
| Cochise IV | Greystone | Rebel Sentry | Turbo |
| Constitution | Guardian 21 | Rebel IV | Turbo RZ |
| Corgi | Guardian 41 | Regiment II | Tuxedo RZ |
| Corona | Hemi | Regenerate | Ultimate |
| Coyote | Honky Tonk | Rendition | Venture |
| Darlington | Hot Rod | Rhambler 2 SRP | Umbrella |
| Davinci | Hunter | Rembrandt | Van Gogh |
| Desire | Inferno | Reunion | Watchdog |
| Dominion | Innovator | Riverside | Wolfpack II |
| Dynamic | Integrity | RNP | Xtremegreen |
| Dynasty | Jaguar 3 | Rocket | |
| Endeavor | Jamboree | Scorpion | |

Approved Kentucky Bluegrass Cultivars:

| | | | |
|---------------|-------------|---------------|---------------|
| 4-Season | Blue Velvet | Gladstone | Quantum Leap |
| Alexa II | Blueberry | Granite | Rambo |
| America | Boomerang | Hampton | Rhapsody |
| Apollo | Brilliant | Harmonie | Rhythm |
| Arcadia | Cabernet | Impact | Rita |
| Aries | Champagne | Jefferson | Royce |
| Armada | Champlain | Juliet | Rubicon |
| Arrow | Chicago II | Jump Start | Rugby II |
| Arrowhead | Corsair | Keeneland | Shiraz |
| Aura | Courtyard | Langara | Showcase |
| Avid | Delight | Liberator | Skye |
| Award | Diva | Madison | Solar Eclipse |
| Awesome | Dynamo | Mercury | Sonoma |
| Bandera | Eagleton | Midnight | Sorbonne |
| Barduke | Emblem | Midnight II | Starburst |
| Barnique | Empire | Moon Shadow | Sudden Impact |
| Baroness | Envicta | Moonlight SLT | Total Eclipse |
| Barrister | Everest | Mystere | Touche |
| Barvette HGT | Everglade | Nu Destiny | Tsunami |
| Bedazzled | Excursion | NuChicago | Unique |
| Belissimo | Freedom II | NuGlade | Valor |
| Bewitched | Freedom III | Odyssey | Voyager II |
| Beyond | Front Page | Perfection | Washington |
| Blacksburg II | Futurity | Pinot | Zinfandel |
| Blackstone | Gaelic | Princeton 105 | |
| Blue Note | Ginney II | Prosperity | |

Approved Hard Fescue Cultivars:

| | | | |
|-------------|-----------|------------|------------|
| Aurora II | Eureka II | Oxford | Scaldis II |
| Aurora Gold | Firefly | Reliant II | Spartan II |
| Berkshire | Granite | Reliant IV | Stonehenge |
| Bighorn GT | Heron | Rescue 911 | |
| Chariot | Nordic | Rhino | |

On cut and fill slopes 2:1 or steeper add 20# Sericea Lespedeza January 1 - December 31.

Fertilizer shall be 10-20-20 analysis. A different analysis of fertilizer may be used provided the 1-2-2 ratio is maintained and the rate of application adjusted to provide the same amount of plant food as a 10-20-20 analysis and as directed.

TEMPORARY SEEDING:

Fertilizer shall be the same analysis as specified for *Seeding and Mulching* and applied at the rate of 400 pounds and seeded at the rate of 50 pounds per acre. German Millet, or Browntop Millet

shall be used in summer months and rye grain during the remainder of the year. The Engineer will determine the exact dates for using each kind of seed.

FERTILIZER TOPDRESSING:

Fertilizer used for topdressing shall be 16-8-8 grade and shall be applied at the rate of 500 pounds per acre. A different analysis of fertilizer may be used provided the 2-1-1 ratio is maintained and the rate of application adjusted to provide the same amount of plant food as 16-8-8 analysis and as directed.

SUPPLEMENTAL SEEDING:

The kinds of seed and proportions shall be the same as specified for *Seeding and Mulching*, and the rate of application may vary from 25# to 75# per acre. The actual rate per acre will be determined prior to the time of topdressing and the Contractor will be notified in writing of the rate per acre, total quantity needed, and areas on which to apply the supplemental seed. Minimum tillage equipment, consisting of a sod seeder shall be used for incorporating seed into the soil as to prevent disturbance of existing vegetation. A clodbuster (ball and chain) may be used where degree of slope prevents the use of a sod seeder.

MOWING:

The minimum mowing height on this project shall be six inches.

LAWN TYPE APPEARANCE:

All areas adjacent to lawns must be hand finished as directed to give a lawn type appearance. Remove all trash, debris, and stones $\frac{3}{4}$ " and larger in diameter or other obstructions that could interfere with providing a smooth lawn type appearance. These areas shall be reseeded to match their original vegetative conditions, unless directed otherwise by the Field Operations Engineer.

MINIMIZE REMOVAL OF VEGETATION:

The Contractor shall minimize removal of vegetation within project limits to the maximum extent practicable. Vegetation along stream banks and adjacent to other jurisdictional resources outside the construction limits shall only be removed upon approval of Engineer. No additional payment will be made for this minimization work.

CONSTRUCTION MATERIALS MANAGEMENT

(3-19-19) (rev. 04-27-20)

Description

The requirements set forth shall be adhered to in order to meet the applicable materials handling requirements of the NCG010000 permit. Structural controls installed to manage construction

materials stored or used on site shall be shown on the E&SC Plan. Requirements for handling materials on construction sites shall be as follows:

Polyacrylamides (PAMS) and Flocculants

Polyacrylamides (PAMS) and flocculants shall be stored in leak-proof containers that are kept under storm-resistant cover or surrounded by secondary containment structures designed to protect adjacent surface waters. PAMS or other flocculants used shall be selected from the NC DWR List of Approved PAMS/Flocculants. The concentration of PAMS and other flocculants used shall not exceed those specified in the NC DWR List of Approved PAMS/Flocculants and in accordance with the manufacturer's instructions. The NC DWR List of Approved PAMS/Flocculants is available at:

https://files.nc.gov/ncdeq/Water+Quality/Environmental+Sciences/ATU/PAM8_30_18.pdf

Equipment Fluids

Fuels, lubricants, coolants, and hydraulic fluids, and other petroleum products shall be handled and disposed of in a manner so as not to enter surface or ground waters and in accordance with applicable state and federal regulations. Equipment used on the site must be operated and maintained properly to prevent discharge of fluids. Equipment, vehicle, and other wash waters shall not be discharged into E&SC basins or other E&SC devices. Alternative controls should be provided such that there is no discharge of soaps, solvents, or detergents.

Waste Materials

Construction materials and land clearing waste shall be disposed of in accordance with North Carolina General Statutes, Chapter 130A, Article 9 - Solid Waste Management, and rules governing the disposal of solid waste (15A NCAC 13B). Areas dedicated for managing construction material and land clearing waste shall be at least 50 feet away from storm drain inlets and surface waters unless it can be shown that no other alternatives are reasonably available. Paint and other liquid construction material waste shall not be dumped into storm drains. Paint and other liquid construction waste washouts should be located at least 50 feet away from storm drain inlets unless there is no alternative. Other options are to install lined washouts or use portable, removable bags or bins. Hazardous or toxic waste shall be managed in accordance with the federal Resource Conservation and Recovery Act (RCRA) and NC Hazardous Waste Rules at 15A NCAC, Subchapter 13A. Litter and sanitary waste shall be managed in a manner to prevent it from entering jurisdictional waters and shall be disposed of offsite.

Herbicide, Pesticide, and Rodenticides

Herbicide, pesticide, and rodenticides shall be stored and applied in accordance with the Federal Insecticide, Fungicide, and Rodenticide Act, North Carolina Pesticide Law of 1971 and labeling restrictions.

Concrete Materials

Concrete materials onsite, including excess concrete, must be controlled and managed to avoid contact with surface waters, wetlands or buffers. No concrete or cement slurry shall be discharged from the site. (Note that discharges from onsite concrete plants require coverage under a separate NPDES permit – NCG140000.) Concrete wash water shall be managed in accordance with the *Concrete Washout Structure* provision. Concrete slurry shall be managed and disposed of in accordance with *NCDOT DGS and HOS DCAR Distribution of Class A Residuals Statewide* (Permit No. WQ0035749). Any hardened concrete residue will be disposed of, or recycled on site, in accordance with state solid waste regulations.

Earthen Material Stock Piles

Earthen material stock piles shall be located at least 50 feet away from storm drain inlets and surface waters unless it can be shown that no other alternatives are reasonably available.

Measurement and Payment

Conditions set within the *Construction Materials Management* provision are incidental to the project for which no direct compensation will be made.

WASTE AND BORROW SOURCES:

(2-16-11) (Rev. 3-17-22)

Payment for temporary erosion control measures, except those made necessary by the Contractor's own negligence or for his own convenience, will be paid for at the appropriate contract unit price for the devices or measures utilized in borrow sources and waste areas.

No additional payment will be made for erosion control devices or permanent seeding and mulching in any commercial borrow or waste pit. All erosion and sediment control practices that may be required on a commercial borrow or waste site will be done at the Contractor's expense.

All offsite Staging Areas, Borrow and Waste sites shall be in accordance with "Borrow and Waste Site Reclamation Procedures for Contracted Projects" located at:

<https://connect.ncdot.gov/resources/roadside/FieldOperationsDocuments/Contract%20Reclamation%20Procedures.pdf>

All forms and documents referenced in the "Borrow and Waste Site Reclamation Procedures for Contracted Projects" shall be included with the reclamation plans for offsite staging areas, and borrow and waste sites.

SAFETY FENCE AND JURISDICTIONAL FLAGGING:

Description

Safety Fence shall consist of furnishing materials, installing and maintaining polyethylene or polypropylene fence along the outside riparian buffer, wetland, or water boundary, or other boundaries located within the construction corridor to mark the areas that have been approved to infringe within the buffer, wetland, endangered vegetation, culturally sensitive areas or water. The fence shall be installed prior to any land disturbing activities.

Interior boundaries for jurisdictional areas noted above shall be delineated by stakes and highly visible flagging.

Jurisdictional boundaries at staging areas, waste sites, or borrow pits, whether considered outside or interior boundaries shall be delineated by stakes and highly visible flagging.

Materials

(A) Safety Fencing

Polyethylene or polypropylene fence shall be a highly visible preconstructed safety fence approved by the Engineer. The fence material shall have an ultraviolet coating.

Either wood posts or steel posts may be used. Wood posts shall be hardwood with a wedge or pencil tip at one end, and shall be at least 5 ft. in length with a minimum nominal 2" x 2" cross section. Steel posts shall be at least 5 ft. in length, and have a minimum weight of 0.85 lb/ft of length.

(B) Boundary Flagging

Wooden stakes shall be 4 feet in length with a minimum nominal 3/4" x 1-3/4" cross section. The flagging shall be at least 1" in width. The flagging material shall be vinyl and shall be orange in color and highly visible.

Construction Methods

No additional clearing and grubbing is anticipated for the installation of this fence. The fence shall be erected to conform to the general contour of the ground.

(A) Safety Fencing

Posts shall be set at a maximum spacing of 10 ft., maintained in a vertical position and hand set or set with a post driver. Posts shall be installed a minimum of 2 ft. into the ground. If hand set, all backfill material shall be thoroughly tamped. Wood posts may be sharpened to a dull point if power driven. Posts damaged by power driving shall be removed and replaced prior to final acceptance. The tops of all wood posts shall be cut at a 30-degree angle. The wood posts may, at the option of the Contractor, be cut at this angle either before or after the posts are erected.

The fence geotextile shall be attached to the wood posts with one 2" galvanized wire staple across each cable or to the steel posts with wire or other acceptable means.

Place construction stakes to establish the location of the safety fence in accordance with Article 105-9 or Article 801-1 of the *Standard Specifications*. No direct pay will be made for the staking of the safety fence. All stakeouts for safety fence shall be considered incidental to the work being paid for as "Construction Surveying", except that where there is no pay item for construction surveying, all safety fence stakeout will be performed by state forces.

The Contractor shall be required to maintain the safety fence in a satisfactory condition for the duration of the project as determined by the Engineer.

(B) Boundary Flagging

Boundary flagging delineation of interior boundaries shall consist of wooden stakes on 25 feet maximum intervals with highly visible orange flagging attached. Stakes shall be installed a minimum of 6" into the ground. Interior boundaries may be staked on a tangent that runs parallel to buffer but must not encroach on the buffer at any location. Interior boundaries of hand clearing shall be identified with a different colored flagging to distinguish it from mechanized clearing.

Boundary flagging delineation of interior boundaries will be placed in accordance with Article 105-9 or Article 801-1 of the *Standard Specifications*. No direct pay will be made for delineation of the interior boundaries. This delineation will be considered incidental to the work being paid for as *Construction Surveying*, except that where there is no pay item or construction surveying the cost of boundary flagging delineation shall be included in the unit prices bid for the various items in the contract. Installation for delineation of all jurisdictional boundaries at staging areas, waste sites, or borrow pits shall consist of wooden stakes on 25 feet maximum intervals with highly visible orange flagging attached. Stakes shall be installed a minimum of 6" into the ground. Additional flagging may be placed on overhanging vegetation to enhance visibility but does not substitute for installation of stakes.

Installation of boundary flagging for delineation of all jurisdictional boundaries at staging areas, waste sites, or borrow pits shall be performed in accordance with Subarticle 230-4(B)(5) or Subarticle 802-2(F) of the *Standard Specifications*. No direct pay will be made for this delineation, as the cost of same shall be included in the unit prices bid for the various items in the contract.

The Contractor shall be required to maintain alternative stakes and highly visible flagging in a satisfactory condition for the duration of the project as determined by the Engineer.

Measurement and Payment

Safety Fence will be measured and paid as the actual number of linear feet of polyethylene or polypropylene fence installed in place and accepted. Such payment will be full compensation including but not limited to furnishing and installing fence geotextile with necessary posts and post bracing, staples, tie wires, tools, equipment and incidentals necessary to complete this work.

Payment will be made under:

Pay Item
Safety Fence

Pay Unit
Linear Foot

CONCRETE WASHOUT STRUCTURE:

(8-17-23)

Description

Concrete washout structures are enclosures above or below grade to contain concrete waste water and associated concrete mix from washing out ready-mix trucks, drums, pumps, or other equipment. Concrete washouts must collect and retain all the concrete washout water and solids, so that this material does not migrate to surface waters or into the ground water. These enclosures are not intended for concrete waste not associated with wash out operations.

The concrete washout structure may include constructed devices above or below ground and or commercially available devices designed specifically to capture concrete wash water.

Materials

Item
Temporary Silt Fence

Section
1605

Safety Fence shall meet the specifications as provided elsewhere in this contract.

Geomembrane basin liner shall meet the following minimum physical properties for low permeability; it shall consist of a polypropylene or polyethylene 10 mil thick geomembrane. If the minimum setback dimensions can be achieved the liner is not required. (5 feet above groundwater, 50 feet from top of bank of perennial stream, other surface water body, or wetland.)

Construction Methods

Build an enclosed earthen berm or excavate to form an enclosure in accordance with the details and as directed.

Install temporary silt fence around the perimeter of the enclosure in accordance with the details and as directed if structure is not located in an area where existing erosion and sedimentation control devices are capable to containing any loss of sediment.

Post a sign with the words "Concrete Washout" in close proximity of the concrete washout area, so it is clearly visible to site personnel. Install safety fence as directed for visibility to construction traffic.

Alternate details for accommodating concrete washout may be submitted for review and approval.

The alternate details shall include the method used to retain and dispose of concrete waste water within the project limits and in accordance with the minimum setback requirements. (5 feet above groundwater, 50 feet from top of bank of perennial stream, other surface water body, or wetland.)

Maintenance and Removal

Maintain the concrete washout structure(s) to provide adequate holding capacity plus a minimum freeboard of 12 inches. Remove and dispose of hardened concrete and return the structure to a functional condition after reaching 75% capacity.

Inspect concrete washout structures for damage and maintain for effectiveness.

Remove the concrete washout structures and sign upon project completion. Grade the earth material to match the existing contours and permanently seed and mulch area.

Measurement and Payment

Concrete Washout Structure will be paid for per each enclosure installed in accordance with the details. If alternate details or commercially available devices are approved, then those devices will also be paid for per each approved and installed device.

Temporary Silt Fence will be measured and paid for in accordance with Article 1605-5 of the *Standard Specifications*.

Safety Fence shall be measured and paid for as provided elsewhere in this contract.

No measurement will be made for other items or for over excavation or stockpiling.

Payment will be made under:

| Pay Item | Pay Unit |
|----------------------------|-----------------|
| Concrete Washout Structure | Each |

LITTER REMOVAL (MOWING AREAS ONLY):
(07-19-22)

Description

This work consists of the pickup, removal, and disposal of litter from roadsides within the construction project prior to mowing operations.

Construction Methods

Provide labor, equipment and materials necessary for the pickup and removal of litter from non-construction sources and the disposal of same into state approved landfills. The Contractor shall abide by all ordinances, laws and regulations regarding disposal of litter and recycling of eligible

materials. Wastes generated from construction activities shall be managed as provided elsewhere in the contract. Litter items may consist of any item not considered normal to the right-of-way, including but not limited to, varied sizes of bottles, cans, paper, tires, tire pieces, lumber, vehicle parts, building supplies, metals, household furnishings, cardboard, plastics, ladders, brush and other items not considered normal to the right of way. Litter removal shall be performed in designated areas within five days prior to any mowing operations and as directed. Designated areas shall include vegetated medians and shoulders within the project limits including all interchange ramps and other areas to be mown. Designated areas may be omitted for litter removal by the Engineer due to safety concerns.

The Contractor shall provide adequate personnel and materials to collect and remove litter. The Contractor shall be responsible for locating and utilizing approved local landfills and recycling facilities. Refer to Section 105-27 of the *Standard Specifications* for potential hazardous materials. All collected litter shall be containerized immediately and kept off the traveled portions of the roadway, shoulders, and rights-of-way (including paved shoulders). All collected litter that is small enough to be placed in a bag shall be bagged immediately. All collected litter that is too large for a bag shall be placed into a vehicle. Extended storage or stockpiling of collected litter and recyclables will not be permitted.

The Contractor's personnel shall dispose of any litter in a landfill approved by North Carolina Division of Waste Management. The Contractor will not be allowed to use NCDOT accounts at the landfills/recycling centers nor be allowed to dispose of the litter in NCDOT trash containers on any NCDOT property.

The Contractor shall report online the number of bags of litter and any recycling on the NCDOT Litter Management Website on the date of the pickup at the following website:

<https://apps.ncdot.gov/LM>

An access code ('Pickup Key') for the online reporting portal may be obtained via emailing the Roadside Environmental Unit Litter Management Section at ncdot.clr@ncdot.gov. The Contractor shall request access to the litter removal reporting website prior to starting initial litter collection operations.

Measurement and Payment

The quantity of litter removal to be performed will be affected by the actual conditions that occur during construction of the project. The quantity of litter removal may be increased, decreased, or eliminated entirely as directed. Such variations in quantity will not be considered as alterations in the details of construction or a change in the character of the work.

Manual Litter Removal will be measured and paid as the actual number of man hours each worker spends picking up litter. Such price and payment will be full compensation for all litter removal work covered by *Litter Removal*, including, but not limited to, furnishing all materials, labor, equipment, transport, reporting, and incidentals necessary to accomplish the work.

Litter Disposal will be measured and paid for by the actual number of tons of litter collected and properly disposed of at a state approved landfill. Such price and payment will be full compensation for all fees, labor, transport, and incidentals necessary to dispose of collected litter associated with *Litter Removal*.

All traffic control necessary to provide a safe work area for *Litter Removal* shall be paid for as specified elsewhere in the contract.

Payment will be made under:

| Pay Item | Pay Unit |
|-----------------------|-----------------|
| Manual Litter Removal | MHR |
| Litter Disposal | TON |

FABRIC INSERT INLET PROTECTION

(1-1-24)

Description

Install, maintain, and remove Fabric Insert Inlet Protection, of the type specified, in inlet structures (catch basins, drop inlets, etc.) in areas where asphalt or concrete may prevent the proper installation of a Rock Inlet Sediment Traps Type C, or as directed by the Engineer.

Materials

Provide a fabric inlet protection device composed of a fitted woven polypropylene geotextile double sewn with nylon thread suspended sack. The Fabric Insert Inlet Protection shall be manufactured to fit the opening of the catch basin or drop inlet or shall have a deflector to direct runoff from the curb opening into the fabric sack. The Fabric Insert Inlet Protection shall have a rigid frame or support system to support the loaded weight of the product. The product shall have lifting loops for removing the device from the basin and will have dump straps attached at the bottom to facilitate the emptying of the device. The Fabric Insert Inlet Protection shall have an overflow system to allow stormwater to enter the inlet structure and avoid ponding on the roadway when the device reaches capacity.

The fitted filter assembly shall have the following physical properties:

Type 1 (High Flow):

| Physical | Test Method | English |
|---------------------------|--------------------|-----------------------------|
| Grab Tensile | ASTM D-4632 | 255 x 275 lbs |
| Minimum Puncture Strength | ASTM D-4833 | 125 lbs |
| Mullen Burst | ASTM D-3786 | 420 PSI |
| Minimum UV Resistance | ASTM D-4355 | 70 %. |
| Flow Rate | ASTM D-4491 | 200 gal/min/ft ² |

| | | |
|------------------|-------------|-----------------------|
| Apparent Opening | ASTM D-4751 | 20 US Sieve |
| Permittivity | ASTM D-4491 | 1.5 sec ⁻¹ |

Type 2 (Low Flow):

| Physical | Test Method | English |
|---------------------------|--------------------|----------------------------|
| Grab Tensile | ASTM D-4632 | 315 x 300 lbs |
| Grab Elongation | ASTM D-4632 | 15 x 15 % |
| Minimum Puncture Strength | ASTM D-4833 | 125 lbs |
| Mullen Burst | ASTM D-3786 | 650 PSI |
| Minimum UV Resistance | ASTM D-4355 | 70 %. |
| Flow Rate | ASTM D-4491 | 40 gal/min/ft ² |
| Apparent Opening | ASTM D-4751 | 40 US Sieve |
| Permittivity | ASTM D-4491 | 0.55 sec ⁻¹ |

Construction Methods

Strictly adhere to the manufacturer’s installation instructions and recommendations. Maintenance shall include regular daily inspections and after each qualifying rain event. The Fabric Insert Inlet Protection shall be emptied, cleaned and placed back into the basin when it reaches 50% capacity or as directed by the Engineer.

Measurement and Payment

Fabric Insert Inlet Protection, Type __ will be measured and paid in units of each of the type specified, complete in place and accepted. Such payment shall be full compensation for furnishing and installing the *Fabric Insert Inlet Protection, Type __* in accordance with this specification and for all required maintenance.

Fabric Insert Inlet Protection Cleanout will be measured and paid in units of each for the maintenance of the device, cleanout and disposal of accumulated sediments.

Payment will be made under:

| Pay Item | Pay Unit |
|---|-----------------|
| Fabric Insert Inlet Protection, Type __ | Each |
| Fabric Insert Inlet Protection Cleanout | Each |

Signals and Intelligent Transportation Systems
Project Special Provisions
(Version 24.0)

Prepared By: GGM
10-Jul-24

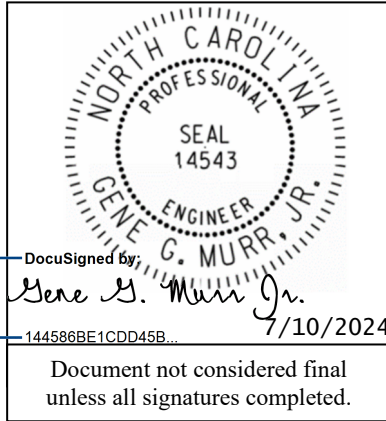

Contents

1. SIGNAL HEADS..... 3

1.1. MATERIALS 3

A. General:..... 3

B. Vehicle Signal Heads: 4

C. Pedestrian Signal Heads:..... 6

2. CONTROLLERS WITH CABINETS..... 8

2.1. MATERIALS – TYPE 2070LX CONTROLLERS 8

2.2. MATERIALS – GENERAL CABINETS 8

2.3. MATERIALS – TYPE 170E CABINETS 9

A. Type 170 E Cabinets General: 9

B. Type 170 E Cabinet Electrical Requirements: 10

C. Type 170 E Cabinet Physical Requirements: 16

D. Model 2018 Enhanced Conflict Monitor: 17

2.4. MATERIALS – TYPE 170 DETECTOR SENSOR UNITS 27

2.5. CONSTRUCTION METHODS..... 27

2.6. MEASUREMENT AND PAYMENT..... 28

3. VIDEO IMAGING LOOP EMULATOR DETECTOR SYSTEMS FOR TEMPORARY INSTALLATION28

3.1. DESCRIPTION 28

3.2. MATERIALS 28

A. General:..... 28

B. Loop Emulator System:..... 30

C. Video Imaging Loop Emulator System Support: 31

3.3. CONSTRUCTION METHODS..... 31

3.4. MEASUREMENT AND PAYMENT..... 32

4. METAL POLE SUPPORTS..... 32

4.1. METAL POLES 32

A. General:..... 32

B. Materials: 35

C. Design: 37

D. Mast Arm Poles:..... 38

4.2. DRILLED PIER FOUNDATIONS FOR METAL POLES 39

A. Description:..... 40

B. Soil Test and Foundation Determination: 40

C. Drilled Pier Construction: 43

4.3. METAL POLE REMOVALS 43

A. Description:..... 43

B. Construction Methods:..... 43

4.4. POLE NUMBERING SYSTEM..... 43

4.5. MEASUREMENT AND PAYMENT..... 43

5. PROTECTIVE COATING FOR METAL POLES..... 44

5.1. GENERAL..... 44

5.2. DESCRIPTION..... 44

5.3. MATERIALS 44

5.4. FACILITY APPROVAL 45

5.5. POWDER COATING..... 46

 A. Galvanizing..... 46

 B. Surface Preparation..... 46

 C. Powder Coating Application and Curing 47

 D. Quality Control 47

 E. Storage, Shipping, and Handling..... 47

 F. Repair of Powder Coated Material..... 47

5.6. ACRYLIC PRIMER AND TOPCOAT PAINT SYSTEM..... 47

 A. Description..... 47

 B. Surface Preparation..... 48

 C. Materials 48

 D. Painting..... 48

 E. Curing 49

 F. Inspection..... 49

 G. Handling..... 49

 H. Repair of Damaged Coating..... 49

5.7. MEASUREMENT AND PAYMENT..... 49

6. ETHERNET EDGE SWITCH 50

6.1. DESCRIPTION 50

 A. Ethernet Edge Switch:..... 50

 B. Network Management:..... 50

6.2. MATERIALS 50

 A. General:..... 50

 B. Compatibility Acceptance..... 50

 C. Standards:..... 51

 D. Functional: 51

 E. Physical Features: 52

 F. Management Capabilities:..... 52

 G. Electrical Specifications:..... 54

 H. Environmental Specifications: 54

 I. Ethernet Patch Cable:..... 54

6.3. CONSTRUCTION METHODS..... 55

 A. General:..... 55

 B. Edge Switch: 55

6.4. MEASUREMENT AND PAYMENT 55

7. REMOVAL OF TYPE II SIGNAL PEDESTALS..... 55

7.1. DESCRIPTION 55

7.2. CONSTRUCTION METHODS..... 55

 (A) General..... 55

 (B) Removal 56

 (C) Disposal..... 56

7.3. MEASUREMENT AND PAYMENT 56

1. SIGNAL HEADS

1.1. MATERIALS

A. General:

Fabricate vehicle signal head housings and end caps from die-cast aluminum. Fabricate 16-inch pedestrian signal head housings and end caps from die-cast aluminum. Provide visor mounting screws, door latches, and hinge pins fabricated from stainless steel. Provide interior screws, fasteners, and metal parts fabricated from stainless steel.

Fabricate tunnel and traditional visors from sheet aluminum.

Paint all surfaces inside and outside of signal housings and doors. Paint outside surfaces of tunnel and traditional visors, messenger cable mounting assemblies, pole and pedestal mounting assemblies, and pedestrian pushbutton housings. Unless otherwise directed by the Engineer, all vehicle signal heads mounted on mast arms or pedestals and pedestrian signal heads mounted on pedestals (mostly for final signal patterns), are to have electrostatically-applied, fused-polyester paint in black (Federal Standard 595C, Color Chip Number 17038) a minimum of 2.5 to 3.5 mils thick. All vehicle signal heads hung on messenger cable (temporary patterns for 09-0402, 09-0401, 09-0400, and one signal upgrade for 09-1325), are to have electrostatically-applied, fused-polyester paint in highway yellow (Federal Standard 595C, Color Chip Number 13538) a minimum of 2.5 to 3.5 mils thick. At the Contractor's option, black colored signal heads may also be used for all temporary patterns in lieu of highway yellow-colored heads if approved by the Engineer in advance. Do not apply paint to the latching hardware or rigid vehicle signal head mounting brackets for mast-arm attachments.

Have the interior surfaces of tunnel and traditional visors painted an alkyd urea black synthetic baking enamel with a minimum gloss reflectance and meeting the requirements of MIL-E-10169, "Enamel Heat Resisting, Instrument Black."

For pole mounting, provide side of pole mounting assemblies with framework and all other hardware necessary to make complete, watertight connections of the signal heads to the poles and pedestals. Fabricate the mounting assemblies and frames from aluminum with all necessary hardware, screws, washers, etc. to be stainless steel. Provide mounting fittings that match the positive locking device on the signal head with the serrations integrally cast into the brackets. Provide upper and lower pole plates that have a 1 ¼-inch vertical conduit entrance hubs with the hubs capped on the lower plate and 1 ½-inch horizontal hubs. Ensure that the assemblies provide rigid attachments to poles and pedestals so as to allow no twisting or swaying of the signal heads. Ensure that all raceways are free of sharp edges and protrusions, and can accommodate a minimum of ten Number 14 AWG conductors.

For pedestal mounting, provide a post-top slipfitter mounting assembly that matches the positive locking device on the signal head with serrations integrally cast into the slipfitter. Provide stainless steel hardware, screws, washers, etc. Provide a minimum of six 3/8 X 3/4-inch long square head bolts for attachment to pedestal. Provide a center post for multi-way slipfitters.

For light emitting diode (LED) traffic signal modules, provide the following requirements for inclusion on the Department's Qualified Products List for traffic signal equipment.

1. Sample submittal,
2. Third-party independent laboratory testing results for each submitted module with evidence of testing and conformance with all of the Design Qualification Testing specified in section 6.4 of each of the following Institute of Transportation Engineers (ITE) specifications:
 - Vehicle Traffic Control Signal Heads – Light Emitting Diode (LED) Circular Signal Supplement

- Vehicle Traffic Control Signal Heads – Light Emitting Diode (LED) Vehicle Arrow Traffic Signal Supplement
- Pedestrian Traffic Control Signal Indications –Light Emitting Diode (LED) Signal Modules.

(Note: The Department currently recognizes two approved independent testing laboratories. They are Intertek ETL Semko and Light Metrics, Incorporated with Garwood Laboratories.

Independent laboratory tests from other laboratories may be considered as part of the QPL submittal at the discretion of the Department,

3. Evidence of conformance with the requirements of these specifications,
4. A manufacturer’s warranty statement in accordance with the required warranty, and
5. Submittal of manufacturer’s design and production documentation for the model, including but not limited to, electrical schematics, electronic component values, proprietary part numbers, bill of materials, and production electrical and photometric test parameters.
6. Evidence of approval of the product to bear the Intertek ETL Verified product label for LED traffic signal modules.

Ensure LED traffic signal modules meet the performance requirements for the minimum period of 15 years, provide a written warranty against defects in materials and workmanship for the modules for a period of 15 years after installation of the modules. During the warranty period, the manufacturer must provide new replacement modules within 45 days of receipt of modules that have failed at no cost to the State. Repaired or refurbished modules may not be used to fulfill the manufacturer’s warranty obligations. Provide manufacturer’s warranty documentation to the Department during evaluation of product for inclusion on Qualified Products List (QPL).

B. Vehicle Signal Heads:

Comply with the ITE standard “Vehicle Traffic Control Signal Heads”. Provide housings with provisions for attaching backplates.

Provide visors that are 10 inches in length for 12-inch vehicle signal heads.

Provide a termination block with one empty terminal for field wiring for each indication plus one empty terminal for the neutral conductor. Have all signal sections wired to the termination block. Provide barriers between the terminals that have terminal screws with a minimum Number 8 thread size and that will accommodate and secure spade lugs sized for a Number 10 terminal screw.

Mount termination blocks in the yellow signal head sections on all in-line vehicle signal heads. Mount the termination block in the red section on five-section vehicle signal heads.

Furnish vehicle signal head interconnecting brackets. Provide one-piece aluminum brackets less than 4.5 inches in height and with no threaded pipe connections. Provide hand holes on the bottom of the brackets to aid in installing wires to the signal heads. Lower brackets that carry no wires and are used only for connecting the bottom signal sections together may be flat in construction.

For messenger cable mounting, provide messenger cable hangers, wire outlet bodies, balance adjusters, bottom caps, wire entrance fitting brackets, and all other hardware necessary to make complete, watertight connections of the vehicle signal heads to the messenger cable. Fabricate messenger cable hanger components, wire outlet bodies and balance adjuster components from stainless steel or malleable iron galvanized in accordance with ASTM A153 (Class A) or ASTM A123. Provide serrated rings made of aluminum. Provide messenger cable hangers with U-bolt clamps. Fabricate washers, screws, hex-head bolts and associated nuts, clevis pins, cotter pins, U-bolt clamps and nuts from stainless steel.

For mast-arm mounting, provide rigid vehicle signal head mounting brackets and all other hardware necessary to make complete, watertight connections of the vehicle signal heads to the mast arms and to provide a means for vertically adjusting the vehicle signal heads to proper alignment. Fabricate the mounting assemblies from aluminum, and provide serrated rings made of aluminum. Provide stainless steel cable attachment assemblies to secure the brackets to the mast arms. Ensure all fastening hardware and fasteners are fabricated from stainless steel.

Provide LED vehicular traffic signal modules (hereafter referred to as modules) that consist of an assembly that uses LEDs as the light source in lieu of an incandescent lamp for use in traffic signal sections. Use LEDs that are aluminum indium gallium phosphorus (AlInGaP) technology for red and yellow indications and indium gallium nitride (InGaN) for green indications. Install the ultra bright type LEDs that are rated for 100,000 hours of continuous operation from -40°F to +165°F. Design modules to have a minimum useful life of 15 years and to meet all parameters of this specification during this period of useful life.

For the modules, provide spade terminals crimped to the lead wires and sized for a #10 screw connection to the existing terminal block in a standard signal head. Do not provide other types of crimped terminals with a spade adapter.

Ensure the power supply is integral to the module assembly. On the back of the module, permanently mark the date of manufacture (month & year) or some other method of identifying date of manufacture.

Tint the red, yellow and green lenses to correspond with the wavelength (chromaticity) of the LED. Transparent tinting films are unacceptable. Provide a lens that is integral to the unit with a smooth outer surface.

1. LED Circular Signal Modules:

Provide modules in the following configurations: 12-inch circular sections. All makes and models of LED modules purchased for use on the State Highway System shall appear on the current NCDOT Traffic Signal Qualified Products List (QPL).

Provide the manufacturer’s model number and the product number (assigned by the Department) for each module that appears on the 2024 or most recent Qualified Products List. In addition, provide manufacturer’s certification in accordance with Article 106-3 of the *Standard Specifications*, that each module meets or exceeds the ITE “Vehicle Traffic Control Signal Heads – Light Emitting Diode (LED) Circular Signal Supplement” dated June 27, 2005 (hereafter referred to as VTCSH Circular Supplement) and other requirements stated in this specification.

Provide modules that meet the following requirements when tested under the procedures outlined in the VTCSH Circular Supplement:

| Module Type | Max. Wattage at 165° F | Nominal Wattage at 77° F |
|------------------------|------------------------|--------------------------|
| 12-inch red circular | 17 | 11 |
| 12-inch green circular | 15 | 15 |

For yellow circular signal modules, provide modules tested under the procedures outlined in the VTCSH Circular Supplement to insure power required at 77° F is 22 Watts or less for the 12-inch circular module.

Note: Use a wattmeter having an accuracy of ±1% to measure the nominal wattage and maximum wattage of a circular traffic signal module. Power may also be derived from voltage, current and power factor measurements.

2. LED Arrow Signal Modules

Provide 12-inch omnidirectional arrow signal modules. All makes and models of LED modules purchased for use on the State Highway System shall appear on the current NCDOT Traffic Signal Qualified Products List (QPL).

Provide the manufacturer’s model number and the product number (assigned by the Department) for each module that appears on the 2024 or most recent Qualified Products List. In addition, provide manufacturer’s certification in accordance with Article 106-3 of the *Standard Specifications*, that each module meets or exceeds the requirements for 12-inch omnidirectional modules specified in the ITE “Vehicle Traffic Control Signal Heads – Light Emitting Diode (LED) Vehicle Arrow Traffic Signal Supplement” dated July 1, 2007 (hereafter referred to as VTCSH Arrow Supplement) and other requirements stated in this specification.

Provide modules that meet the following requirements when tested under the procedures outlined in the VTCSH Arrow Supplement:

| Module Type | Max. Wattage at 165° F | Nominal Wattage at 77° F |
|---------------------|------------------------|--------------------------|
| 12-inch red arrow | 12 | 9 |
| 12-inch green arrow | 11 | 11 |

For yellow arrow signal modules, provide modules tested under the procedures outlined in the VTCSH Arrow Supplement to insure power required at 77° F is 12 Watts or less.

Note: Use a wattmeter having an accuracy of ±1% to measure the nominal wattage and maximum wattage of an arrow traffic signal module. Power may also be derived from voltage, current and power factor measurements.

C. Pedestrian Signal Heads:

Provide pedestrian signal heads with international symbols that meet the MUTCD. Do not provide letter indications.

Comply with the ITE standard for “Pedestrian Traffic Control Signal Indications” and the following sections of the ITE standard for “Vehicle Traffic Control Signal Heads” in effect on the date of advertisement:

- Section 3.00 - “Physical and Mechanical Requirements”
- Section 4.01 - “Housing, Door, and Visor: General”
- Section 4.04 - “Housing, Door, and Visor: Materials and Fabrication”
- Section 7.00 - “Exterior Finish”

Provide a double-row termination block with three empty terminals and number 10 screws for field wiring. Provide barriers between the terminals that accommodate a spade lug sized for number 10 terminal screws. Mount the termination block in the hand section. Wire all signal sections to the terminal block.

Where required by the plans, provide 16-inch pedestrian signal heads with traditional three-sided, rectangular visors, 6 inches long.

Provide 2-inch diameter pedestrian push-buttons with weather-tight housings fabricated from die-cast aluminum and threading in compliance with the NEC for rigid metal conduit. Provide a weep hole in the housing bottom and ensure that the unit is vandal resistant.

Provide push-button housings that are suitable for mounting on flat or curved surfaces and that will accept 1/2-inch conduit installed in the top. Provide units that have a heavy-duty push-button assembly

with a sturdy, momentary, normally-open switch. Have contacts that are electrically insulated from the housing and push-button. Ensure that the push-buttons are rated for a minimum of 5 mA at 24 volts DC and 250 mA at 12 volts AC. NOTE - Paint all inside and outside surfaces of pedestrian signal heads and pedestrian pushbutton housings. Pedestrian signal heads are to have electrostatically-applied, fused-polyester paint in black (Federal Standard 595C, Color Chip Number 17038) a minimum of 2.5 to 3.5 mils thick.

Provide standard R10-3 signs with mounting hardware that comply with the MUTCD in effect on the date of advertisement. Provide R10-3E signs for countdown pedestrian heads and R10-3B for non-countdown pedestrian heads.

Design the LED pedestrian traffic signal modules (hereafter referred to as modules) for installation into standard pedestrian traffic signal sections that do not contain the incandescent signal section reflector, lens, eggcrate visor, gasket, or socket. Provide modules that consist of an assembly that uses LEDs as the light source in lieu of an incandescent lamp. Use LEDs that are of the latest aluminum indium gallium phosphorus (AlInGaP) technology for the Portland Orange hand and countdown displays. Use LEDs that are of the latest indium gallium nitride (InGaN) technology for the Lunar White walking man displays. Install the ultra-bright type LEDs that are rated for 100,000 hours of continuous operation from -40°F to +165°F. Design modules to have a minimum useful life of 60 months and to meet all parameters of this specification during this period of useful life.

Design all modules to operate using a standard 3 - wire field installation. Provide spade terminals crimped to the lead wires and sized for a #10 screw connection to the existing terminal block in a standard pedestrian signal housing. Do not provide other types of crimped terminals with a spade adapter.

Ensure the power supply is integral to the module assembly. On the back of the module, permanently mark the date of manufacture (month & year) or some other method of identifying date of manufacture.

Provide modules in the following configuration: 16-inch displays which have the solid hand/walking man overlay on the left and the countdown on the right. All makes and models of LED modules purchased for use on the State Highway System shall appear on the current NCDOT Traffic Signal Qualified Products List (QPL).

Provide the manufacturer’s model number and the product number (assigned by the Department) for each module that appears on the 2024 or most recent Qualified Products List. In addition, provide manufacturer’s certification in accordance with Article 106-3 of the *Standard Specifications*, that each module meets or exceeds the ITE “Pedestrian Traffic Control Signal Indicators - Light Emitting Diode (LED) Signal Modules” dated August 04, 2010 (hereafter referred to as PTCSI Pedestrian Standard) and other requirements stated in this specification.

Provide modules that meet the following requirements when tested under the procedures outlined in the PTCSI Pedestrian Standard:

| Module Type | Max. Wattage at 165° F | Nominal Wattage at 77° F |
|------------------------|------------------------|--------------------------|
| Hand Indication | 16 | 13 |
| Walking Man Indication | 12 | 9 |
| Countdown Indication | 16 | 13 |

Note: Use a wattmeter having an accuracy of ±1% to measure the nominal wattage and maximum wattage of a circular traffic signal module. Power may also be derived from voltage, current and power factor measurements.

Provide module lens that is hard coated or otherwise made to comply with the material exposure and weathering effects requirements of the Society of Automotive Engineers (SAE) J576. Ensure all exposed components of the module are suitable for prolonged exposure to the environment, without appreciable degradation that would interfere with function or appearance.

Ensure the countdown display continuously monitors the traffic controller to automatically learn the pedestrian phase time and update for subsequent changes to the pedestrian phase time.

Ensure the countdown display begins normal operation upon the completion of the preemption sequence and no more than one pedestrian clearance cycle.

2. CONTROLLERS WITH CABINETS

2.1. MATERIALS – TYPE 2070LX CONTROLLERS

Furnish model 2070LX controller units that conform to CALTRANS *Transportation Electrical Equipment Specifications* (TEES) (dated March 12, 2009, plus Errata 1 dated January 21, 2010 and Errata 2 dated December 5, 2014) except as required herein.

The Department will provide software at the beginning of the burning-in period. Contractor shall give 5 working days notice before needing software. Program software provided by the Department.

Provide model 2070LX controllers with Linux kernel 2.6.18 or higher and device drivers, composed of the unit chassis and at a minimum the following modules and assemblies:

- MODEL 2070-1C, CPU Module, Single Board, with 8Mb Datakey (blue in color)
- MODEL 2070-2E+, Field I/O Module (FI/O)
 - Note: Configure the Field I/O Module to disable both the External WDT Shunt/Toggle Switch and SP3 (SP3 active indicator is “off”)
- MODEL 2070-3B, Front Panel Module (FP), Display B (8x40)
- MODEL 2070-4A, Power Supply Module, 10 AMP

Provide a Board Support Package (BSP) to the state and to any specified applications software manufacturer when requested by the state to facilitate the porting of application software.

2.2. MATERIALS – GENERAL CABINETS

Provide a moisture resistant coating on all circuit boards.

Provide one 20 mm diameter radial lead UL-recognized metal oxide varistor (MOV) between each load switch field terminal and equipment ground. Electrical performance is outlined below.

| PROPERTIES OF MOV SURGE PROTECTOR | |
|--|--------------------------|
| Maximum Continuous Applied Voltage at 185° F | 150 VAC (RMS) 200 VDC |
| Maximum Peak 8x20µs Current at 185° F | 6500 A |
| Maximum Energy Rating at 185° F | 80 J |
| Voltage Range 1 mA DC Test at 77° F | 212-268 V |
| Max. Clamping Voltage 8x20µs, 100A at 77° F | 395 V |
| Typical Capacitance (1 MHz) at 77° F | 1600 pF |

Provide a power line surge protector that is a two-stage device that will allow connection of the radio frequency interference filter between the stages of the device. Ensure that a maximum continuous current is at least 10A at 120V. Ensure that the device can withstand a minimum of 20 peak surge current occurrences at 20,000A for an 8x20 microsecond waveform. Provide a maximum clamp voltage of 395V at 20,000A with a nominal series inductance of 200µh. Ensure that the voltage does not exceed 395V. Provide devices that comply with the following:

| Frequency (Hz) | Minimum Insertion Loss (dB) |
|----------------|-----------------------------|
| 60 | 0 |
| 10,000 | 30 |
| 50,000 | 55 |
| 100,000 | 50 |
| 500,000 | 50 |
| 2,000,000 | 60 |
| 5,000,000 | 40 |
| 10,000,000 | 20 |
| 20,000,000 | 25 |

2.3. MATERIALS – TYPE 170E CABINETS

A. Type 170 E Cabinets General:

Conform to the city of Los Angeles’ Specification No. 54-053-08, *Traffic Signal Cabinet Assembly Specification* (dated July 2008), except as required herein.

Furnish model 332 base mounted cabinets configured for 8 vehicle phases, 4 pedestrian phases, and 6 overlaps. When overlaps are required, provide auxiliary output files for the overlaps. Do not reassign load switches to accommodate overlaps unless shown on electrical details.

Provide model 200 load switches, model 222 loop detector sensors, model 252 AC isolators, and model 242 DC isolators according to the electrical details. As a minimum, provide one (1) model 2018 conflict monitor, one (1) model 206L power supply unit, two (2) model 204 flashers, one (1) DC isolator

(located in slot I14), and four (4) model 430 flash transfer relays (provide seven (7) model 430 flash transfer relays if auxiliary output file is installed) with each cabinet.

B. Type 170 E Cabinet Electrical Requirements:

Provide a cabinet assembly designed to ensure that upon leaving any cabinet switch or conflict monitor initiated flashing operation, the controller starts up in the programmed start up phases and start up interval.

Furnish two sets of non-fading cabinet wiring diagrams and schematics in a paper envelope or container and placed in the cabinet drawer.

All AC+ power is subject to radio frequency signal suppression.

Provide surge suppression in the cabinet for each type of cabinet device. Provide surge protection for the full capacity of the cabinet input file. Provide surge suppression devices that operate properly over a temperature range of -40° F to +185° F. Ensure the surge suppression devices provide both common and differential modes of protection.

Provide a pluggable power line surge protector that is installed on the back of the PDA (power distribution assembly) chassis to filter and absorb power line noise and switching transients. Ensure the device incorporates LEDs for failure indication and provides a dry relay contact closure for the purpose of remote sensing. Ensure the device meets the following specifications:

- Peak Surge Current (Single pulse, 8x20µs).....20,000A
- Occurrences (8x20µs waveform).....10 minimum @ 20,000A
- Maximum Clamp Voltage.....395VAC
- Operating Current.....15 amps
- Response Time.....< 5 nanoseconds

Provide a loop surge suppressor for each set of loop terminals in the cabinet. Ensure the device meets the following specifications:

- Peak Surge Current (6 times, 8x20µs)
 - (Differential Mode).....400A
 - (Common Mode).....1,000A
- Occurrences (8x20µs waveform).....500 min @ 200A
- Maximum Clamp Voltage
 - (Differential Mode @400A).....35V
 - (Common Mode @1,000A).....35V
- Response Time.....< 5 nanoseconds
- Maximum Capacitance.....35 pF

Provide a data communications surge suppressor for each communications line entering or leaving the cabinet. Ensure the device meets the following specifications:

- Peak Surge Current (Single pulse, 8x20µs).....10,000A

| | |
|--|-------------------------------|
| Occurrences (8x20 μ s waveform)..... | 100 min @ 2,000A |
| Maximum Clamp Voltage..... | Rated for equipment protected |
| Response Time..... | < 1 nanosecond |
| Maximum Capacitance..... | 1,500 pF |
| Maximum Series Resistance..... | 15 Ω |

Provide a DC signal surge suppressor for each DC input channel in the cabinet. Ensure the device meets the following specifications:

| | |
|--|----------------|
| Peak Surge Current (Single pulse, 8x20 μ s)..... | 10,000A |
| Occurrences (8x20 μ s waveform)..... | 100 @ 2,000A |
| Maximum Clamp Voltage..... | 30V |
| Response Time..... | < 1 nanosecond |

Provide a 120 VAC signal surge suppressor for each AC+ interconnect signal input. Ensure the device meets the following specifications:

| | |
|--|-----------------------|
| Peak Surge Current (Single pulse, 8x20 μ s)..... | 20,000A |
| Maximum Clamp Voltage..... | 350VAC |
| Response Time..... | < 200 nanoseconds |
| Discharge Voltage..... | <200 Volts @ 1,000A |
| Insulation Resistance..... | \geq 100 M Ω |

Provide conductors for surge protection wiring that are of sufficient size (ampacity) to withstand maximum overcurrents which could occur before protective device thresholds are attained and current flow is interrupted.

If additional surge protected power outlets are needed to accommodate fiber transceivers, modems, etc., install a UL listed, industrial, heavy-duty type power outlet strip with a minimum rating of 15 A / 125 VAC, 60 Hz. Provide a strip that has a minimum of 3 grounded outlets. Ensure the power outlet strip plugs into one of the controller unit receptacles located on the rear of the PDA. Ensure power outlet strip is mounted securely; provide strain relief if necessary.

Provide a door switch in the front and a door switch in the rear of the cabinet that will provide the controller unit with a Door Ajar alarm when either the front or the rear door is open. Ensure the door switches apply DC ground to the Input File when either the front door or the rear door is open.

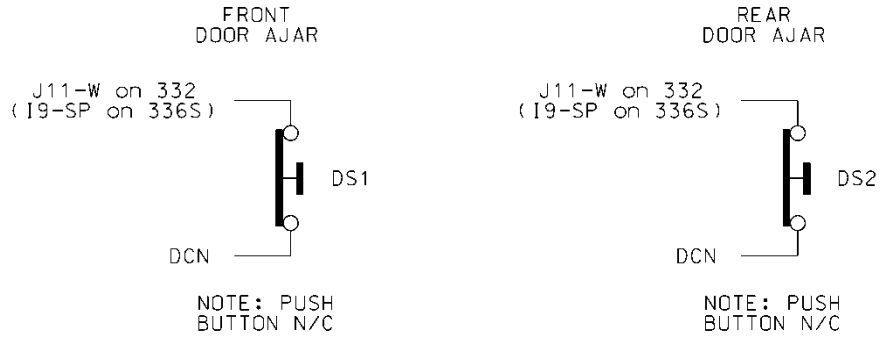

Furnish a fluorescent fixture in the rear across the top of the cabinet and another fluorescent fixture in the front across the top of the cabinet at a minimum. Ensure that the fixtures provide sufficient light to illuminate all terminals, labels, switches, and devices in the cabinet. Conveniently locate the fixtures so as not to interfere with a technician’s ability to perform work on any devices or terminals in the cabinet. Provide a protective diffuser to cover exposed bulbs. Install 16 watt T-4 lamps in the fluorescent fixtures. Provide a door switch to provide power to each fixture when the respective door is open. Wire the fluorescent fixtures to the 15 amp ECB (equipment circuit breaker).

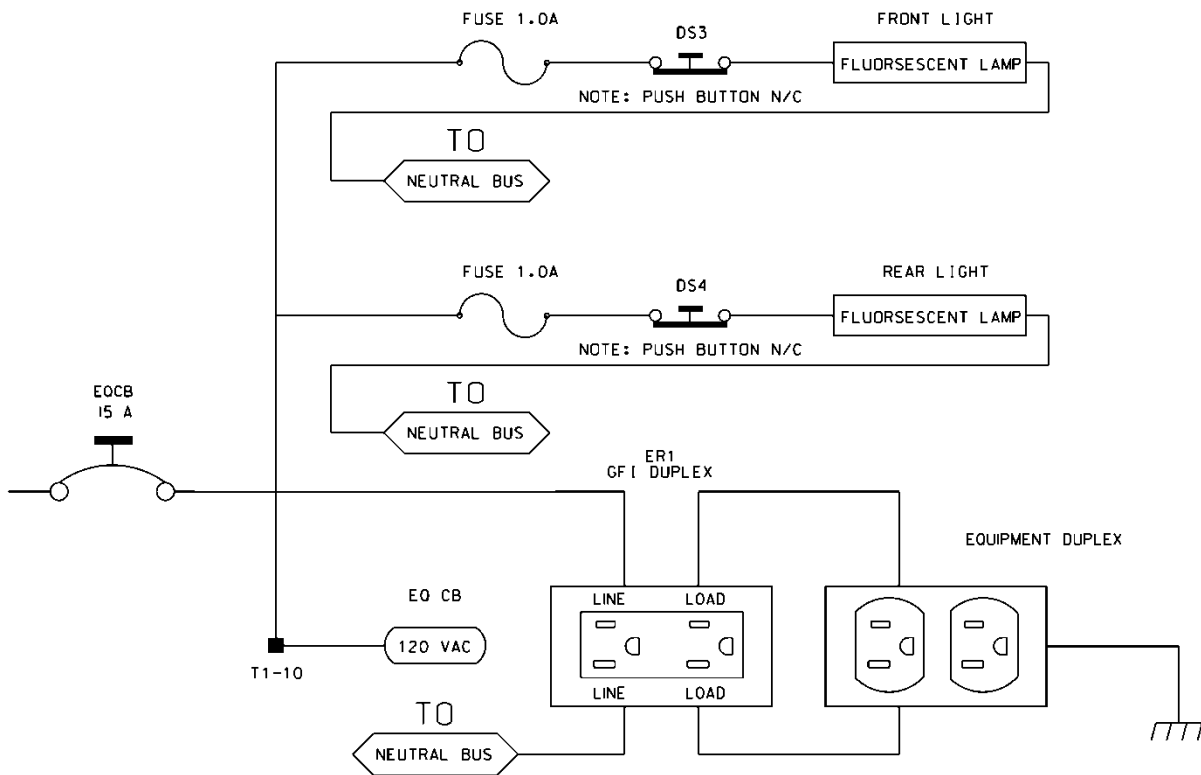

Furnish a police panel with a police panel door. Ensure that the police panel door permits access to the police panel when the main door is closed. Ensure that no rainwater can enter the cabinet even with the police panel door open. Provide a police panel door hinged on the right side as viewed from the front. Provide a police panel door lock that is keyed to a standard police/fire call box key. In addition to the requirements of LA Specification No. 54-053-08, provide the police panel with a toggle switch

connected to switch the intersection operation between normal stop-and-go operation (AUTO) and manual operation (MANUAL). Ensure that manual control can be implemented using inputs and software such that the controller provides full programmed clearance times for the yellow clearance and red clearance for each phase while under manual control.

Provide a 1/4-inch locking phone jack in the police panel for a hand control to manually control the intersection. Provide sufficient room in the police panel for storage of a hand control and cord.

For model 332 base mounted cabinets, ensure terminals J14-E and J14-K are wired together on the rear of the Input File. Connect TB9-12 (J14 Common) on the Input Panel to T1-2 (AC-) on the rear of the PDA.

Provide detector test switches mounted at the top of the cabinet rack or other convenient location which may be used to place a call on each of eight phases based on the chart below. Provide three positions for each switch: On (place call), Off (normal detector operation), and Momentary On (place momentary call and return to normal detector operation after switch is released). Ensure that the switches are located such that the technician can read the controller display and observe the intersection.

Connect detector test switches for cabinets as follows:

| 332 Cabinet | |
|-------------------------------|------------------|
| Detector Call Switches | Terminals |
| Phase 1 | I1-W |
| Phase 2 | I4-W |
| Phase 3 | I5-W |
| Phase 4 | I8-W |
| Phase 5 | J1-W |
| Phase 6 | J4-W |
| Phase 7 | J5-W |
| Phase 8 | J8-W |

Provide the PCB 28/56 connector for the conflict monitor unit (CMU) with 28 independent contacts per side, dual-sided with 0.156 inch contact centers. Provide the PCB 28/56 connector contacts with solder eyelet terminations. Ensure all connections to the PCB 28/56 connector are soldered to the solder eyelet terminations.

Ensure that all cabinets have the CMU connector wired according to the 332 cabinet connector pin assignments (include all wires for auxiliary output file connection). Wire pins 13, 16, R, and U of the CMU connector to a separate 4 pin plug, P1, as shown below. Provide a second plug, P2, which will mate with P1 and is wired to the auxiliary output file as shown below. Provide an additional plug, P3, which will mate with P1 and is wired to the pedestrian yellow circuits as shown below. When no auxiliary output file is installed in the cabinet, provide wires for the green and yellow inputs for channels 11, 12, 17, and 18, the red inputs for channels 17 and 18, and the wires for the P2 plug. Terminate the two-foot wires with ring type lugs, insulated, and bundled for optional use.

| PIN | P1 | | P2 | | P3 | |
|-----|----------|---------|----------|---------|----------|---------|
| | FUNCTION | CONN TO | FUNCTION | CONN TO | FUNCTION | CONN TO |
| 1 | CH-9G | CMU-13 | OLA-GRN | A123 | 2P-YEL | 114 |
| 2 | CH-9Y | CMU-16 | OLA-YEL | A122 | 4P-YEL | 105 |
| 3 | CH-10G | CMU-R | OLB-GRN | A126 | 6P-YEL | 120 |
| 4 | CH-10Y | CMU-U | OLB-YEL | A125 | 8P-YEL | 111 |

Do not provide the P20 terminal assembly (red monitor board) or red interface ribbon cable as specified in LA Specification No. 54-053-08.

Provide a P20 connector that mates with and is compatible with the red interface connector mounted on the front of the conflict monitor. Ensure that the P20 connector and the red interface connector on the conflict monitor are center polarized to ensure proper connection. Ensure that removal of the P20 connector will cause the conflict monitor to recognize a latching fault condition and place the cabinet into flashing operation.

Wire the P20 connector to the output file and auxiliary output file using 22 AWG stranded wires. Ensure the length of these wires is a minimum of 42 inches in length. Provide a durable braided sleeve around the wires to organize and protect the wires.

Wire the P20 connector to the traffic signal red displays to provide inputs to the conflict monitor as shown below. Ensure the pedestrian Don't Walk circuits are wired to channels 13 through 16 of the P20 connector. When no auxiliary output file is installed in the cabinet, provide wires for channels 9 through 12 reds. Provide a wire for special function 1. Terminate the unused wires with ring type lugs, insulated, and bundled for optional use.

| P20 Connector | | | | | |
|---------------|----------------|---------|-----|-----------------|---------|
| PIN | FUNCTION | CONN TO | PIN | FUNCTION | CONN TO |
| 1 | Channel 15 Red | 119 | 2 | Channel 16 Red | 110 |
| 3 | Channel 14 Red | 104 | 4 | Chassis GND | 01-9 |
| 5 | Channel 13 Red | 113 | 6 | N/C | |
| 7 | Channel 12 Red | AUX 101 | 8 | Spec Function 1 | |
| 9 | Channel 10 Red | AUX 124 | 10 | Channel 11 Red | AUX 114 |
| 11 | Channel 9 Red | AUX 121 | 12 | Channel 8 Red | 107 |
| 13 | Channel 7 Red | 122 | 14 | Channel 6 Red | 134 |
| 15 | Channel 5 Red | 131 | 16 | Channel 4 Red | 101 |
| 17 | Channel 3 Red | 116 | 18 | Channel 2 Red | 128 |
| 19 | Channel 1 Red | 125 | 20 | Red Enable | 01-14 |

Ensure the controller unit outputs to the auxiliary output file are pre-wired to the C5 connector. When no auxiliary output file is installed in the cabinet, connect the C5 connector to a storage socket located on the Input Panel or on the rear of the PDA.

Do not wire pin 12 of the load switch sockets.

In addition to the requirements of LA Specification No. 54-053-08, ensure relay K1 on the Power Distribution Assembly (PDA) is a four pole relay and K2 on the PDA is a two pole relay.

Provide a two pole, ganged circuit breaker for the flash bus circuit. Ensure the flash bus circuit breaker is an inverse time circuit breaker rated for 10 amps at 120 VAC with a minimum of 10,000 RMS symmetrical amperes short circuit current rating. Do not provide the auxiliary switch feature on the flash bus circuit breaker. Ensure the ganged flash bus circuit breaker is certified by the circuit breaker manufacturer to provide gang tripping operation.

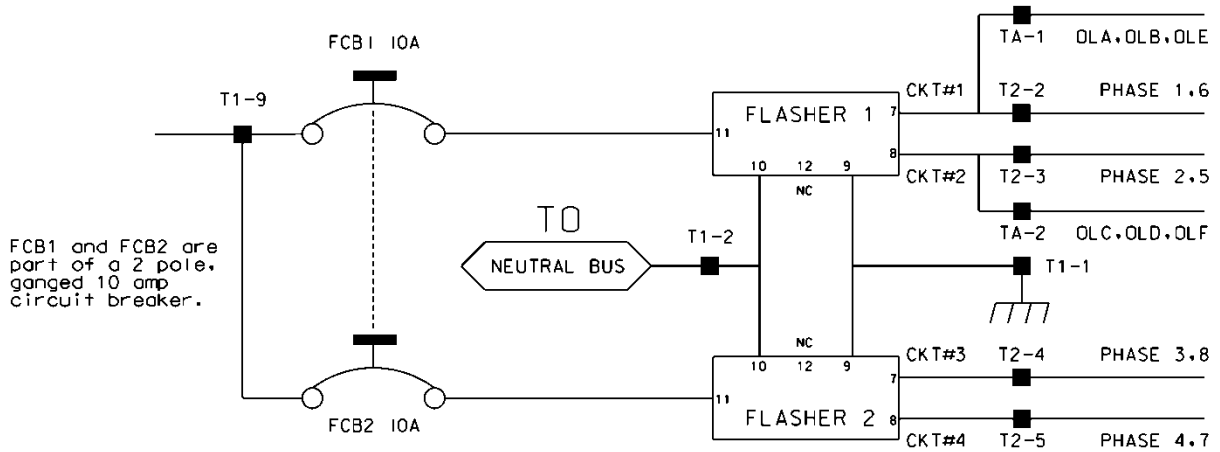

Ensure auxiliary output files are wired as follows:

| AUXILIARY OUTPUT FILE | |
|-------------------------------|---|
| TERMINAL BLOCK TA ASSIGNMENTS | |
| POSITION | FUNCTION |
| 1 | Flasher Unit #1, Circuit 1/FTR1 (OLA, OLB)/FTR3 (OLE) |
| 2 | Flasher Unit #1, Circuit 2/FTR2 (OLC, OLD)/FTR3 (OLF) |
| 3 | Flash Transfer Relay Coils |
| 4 | AC - |
| 5 | Power Circuit 5 |
| 6 | Power Circuit 5 |
| 7 | Equipment Ground Bus |
| 8 | NC |

Provide four spare load resistors mounted in each cabinet. Ensure each load resistor is rated as shown in the table below. Wire one side of each load resistor to AC-. Connect the other side of each resistor to a separate terminal on a four (4) position terminal block. Mount the load resistors and terminal block either inside the back of Output File No. 1 or on the upper area of the Service Panel.

| ACCEPTABLE LOAD RESISTOR VALUES | |
|------------------------------------|-----------|
| VALUE (ohms) | WATTAGE |
| 1.5K – 1.9 K | 25W (min) |
| 2.0K – 3.0K | 10W (min) |

Provide Model 200 load switches, Model 204 flashers, Model 242 DC isolators, Model 252 AC isolators, and Model 206L power supply units that conform to CALTRANS' "Transportation Electrical Equipment Specifications" dated March 12, 2009 with Erratum 1.

C. Type 170 E Cabinet Physical Requirements:

Do not mold, cast, or scribe the name "City of Los Angeles" on the outside of the cabinet door as specified in LA Specification No. 54-053-08. Do not provide a Communications Terminal Panel as specified in LA Specification No. 54-053-08. Do not provide terminal block TBB on the Service Panel. Do not provide Cabinet Verification Test Program software or associated test jigs as specified in LA Specification No. 54-053-08.

Furnish unpainted, natural, aluminum cabinet shells. Ensure that all non-aluminum hardware on the cabinet is stainless steel or a Department approved non-corrosive alternate.

Ensure the lifting eyes, gasket channels, police panel, and all supports welded to the enclosure and doors are fabricated from 0.125 inch minimum thickness aluminum sheet and meet the same standards as the cabinet and doors.

Provide front and rear doors with latching handles that allow padlocking in the closed position. Furnish 0.75 inch minimum diameter stainless steel handles with a minimum 0.5 inch shank. Place the padlocking attachment at 4.0 inches from the handle shank center to clear the lock and key. Provide an additional 4.0 inches minimum gripping length.

Provide Corbin #2 locks on the front and rear doors. Provide one (1) Corbin #2 and one (1) police master key with each cabinet. Ensure main door locks allow removal of keys in the locked position only.

Provide a surge protection panel with 16 loop surge protection devices and designed to allow sufficient free space for wire connection/disconnection and surge protection device replacement. For model 332 cabinets, provide an additional 20 loop surge protection devices. Provide an additional two AC+ interconnect surge devices to protect one slot and eight DC surge protection devices to protect four slots. Provide no protection devices on slot I14.

For base mounted cabinets, mount surge protection panels on the left side of the cabinet as viewed from the rear. Attach each panel to the cabinet rack assembly using bolts and make it easily removable. Mount the surge protection devices in vertical rows on each panel and connect the devices to one side of 12 position, double row terminal blocks with #8 screws. For each surge protection panel, terminate all grounds from the surge protection devices on a copper equipment ground bus attached to the surge protection panel. Wire the terminals to the rear of a standard input file using spade lugs for input file protection.

Provide permanent labels that indicate the slot and the pins connected to each terminal that may be viewed from the rear cabinet door. Label and orient terminals so that each pair of inputs is next to each other. Indicate on the labeling the input file (I or J), the slot number (1-14) and the terminal pins of the input slots (either D & E for upper or J & K for lower).

Provide a minimum 14 x 16 inch pull out, hinged top shelf located immediately below controller mounting section of the cabinet. Ensure the shelf is designed to fully expose the table surface outside the controller at a height approximately even with the bottom of the controller. Ensure the shelf has a storage bin interior which is a minimum of 1 inch deep and approximately the same dimensions as the shelf. Provide an access to the storage area by lifting the hinged top of the shelf. Fabricate the shelf and slide from aluminum or stainless steel and ensure the assembly can support the 2070L controller plus 15 pounds of additional weight. Ensure shelf has a locking mechanism to secure it in the fully extended position and does not inhibit the removal of the 2070L controller or removal of cards inside the controller when fully extended. Provide a locking mechanism that is easily released when the shelf is to be returned to its non-use position directly under the controller.

D. Model 2018 Enhanced Conflict Monitor:

Furnish Model 2018 Enhanced Conflict Monitors that provide monitoring of 18 channels. Ensure each channel consists of a green, yellow, and red field signal input. Ensure that the conflict monitor meets or exceeds CALTRANS' Transportation Electrical Equipment Specifications dated March 12, 2009, with Erratum 1 (hereafter referred to as CALTRANS' 2009 TEES) for a model 210 monitor unit and other requirements stated in this specification.

Ensure the conflict monitor is provided with an 18 channel conflict programming card. Pin EE and Pin T of the conflict programming card shall be connected together. Pin 16 of the conflict programming card shall be floating. Ensure that the absence of the conflict programming card will cause the conflict monitor to trigger (enter into fault mode), and remain in the triggered state until the programming card is properly inserted and the conflict monitor is reset.

Provide a conflict monitor that incorporates LED indicators into the front panel to dynamically display the status of the monitor under normal conditions and to provide a comprehensive review of field inputs with monitor status under fault conditions. Ensure that the monitor indicates the channels that were active during a conflict condition and the channels that experienced a failure for all other per channel fault conditions detected. Ensure that these indications and the status of each channel are retained until the Conflict Monitor is reset. Furnish LED indicators for the following:

- AC Power (Green LED indicator)
- VDC Failed (Red LED indicator)
- WDT Error (Red LED indicator)
- Conflict (Red LED indicator)
- Red Fail (Red LED indicator)
- Dual Indication (Red LED indicator)
- Yellow/Clearance Failure (Red LED indicator)
- PCA/PC Ajar (Red LED indicator)
- Monitor Fail/Diagnostic Failure (Red LED indicator)
- 54 Channel Status Indicators (1 Red, 1 Yellow, and 1 Green LED indicator for each of the 18 channels)

Provide a switch to set the Red Fail fault timing. Ensure that when the switch is in the ON position the Red Fail fault timing value is set to 1350 +/- 150 ms (2018 mode). Ensure that when the switch is in the OFF position the Red Fail fault timing value is set to 850 +/- 150 ms (210 mode).

Provide a switch to set the Watchdog fault timing. Ensure that when the switch is in the ON position the Watchdog fault timing value is set to 1.0 +/- 0.1 s (2018 mode). Ensure that when the switch is in the OFF position the Watchdog fault timing value is set to 1.5 +/- 0.1 s (210 mode).

Provide a jumper or switch to set the AC line brown-out levels. Ensure that when the jumper is present or the switch is in the ON position the AC line dropout voltage threshold is 98 +/- 2 Vrms, the AC line restore voltage threshold is 103 +/- 2 Vrms, and the AC line brown-out timing value is set to 400 +/- 50ms (2018 mode). Ensure that when the jumper is not present or the switch is in the OFF position the AC line dropout voltage threshold is 92 +/- 2 Vrms, the AC line restore voltage threshold is 98 +/- 2 Vrms, and the AC line brown-out timing value is set to 80 +/- 17 ms (210 mode).

Provide a jumper or switch that will enable and disable the Watchdog Latch function. Ensure that when the jumper is not present or the switch is in the OFF position the Watchdog Latch function is disabled. In this mode of operation, a Watchdog fault will be reset following a power loss, brownout, or power interruption. Ensure that when the jumper is present or the switch is in the ON position the Watchdog Latch function is enabled. In this mode of operation, a Watchdog fault will be retained until a Reset command is issued.

Provide a jumper that will reverse the active polarity for pin #EE (output relay common). Ensure that when the jumper is not present pin #EE (output relay common) will be considered 'Active' at a voltage greater than 70 Vrms and 'Not Active' at a voltage less than 50 Vrms (Caltrans mode). Ensure that when the jumper is present pin #EE (output relay common) will be considered 'Active' at a voltage less than 50 Vrms and 'Not Active' at a voltage greater than 70 Vrms (Failsafe mode).

In addition to the connectors required by CALTRANS' 2009 TEES, provide the conflict monitor with a red interface connector mounted on the front of the monitor. Ensure the connector is a 20 pin, right angle, center polarized, male connector with latching clip locks and polarizing keys. Ensure the right angle solder tails are designed for a 0.062" thick printed circuit board. Keying of the connector shall be between pins 3 and 5, and between 17 and 19. Ensure the connector has two rows of pins with the odd numbered pins on one row and the even pins on the other row. Ensure the connector pin row spacing is 0.10" and pitch is 0.10". Ensure the mating length of the connector pins is 0.24". Ensure the pins are finished with gold plating 30μ" thick.

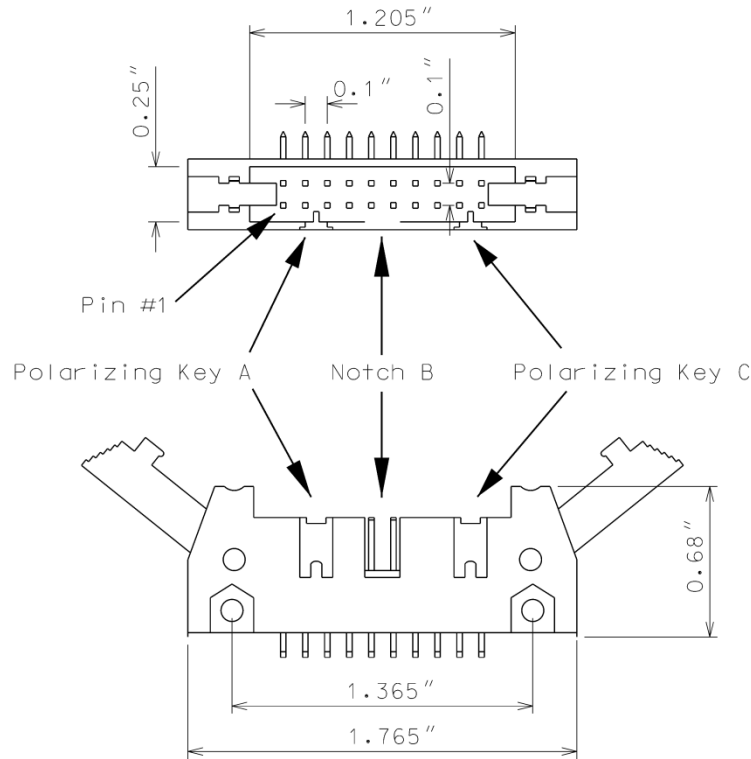

Ensure the red interface connector pins on the monitor have the following functions:

| Pin # | Function | Pin # | Function |
|-------|----------------|-------|--------------------|
| 1 | Channel 15 Red | 2 | Channel 16 Red |
| 3 | Channel 14 Red | 4 | Chassis Ground |
| 5 | Channel 13 Red | 6 | Special Function 2 |
| 7 | Channel 12 Red | 8 | Special Function 1 |
| 9 | Channel 10 Red | 10 | Channel 11 Red |
| 11 | Channel 9 Red | 12 | Channel 8 Red |
| 13 | Channel 7 Red | 14 | Channel 6 Red |
| 15 | Channel 5 Red | 16 | Channel 4 Red |
| 17 | Channel 3 Red | 18 | Channel 2 Red |
| 19 | Channel 1 Red | 20 | Red Enable |

Ensure that removal of the P20 cable connector will cause the conflict monitor to recognize a latching fault condition and place the cabinet into flashing operation.

Provide Special Function 1 and Special Function 2 inputs to the unit which shall disable only Red Fail Monitoring when either input is sensed active. A Special Function input shall be sensed active when the input voltage exceeds 70 Vrms with a minimum duration of 550 ms. A Special Function input shall be sensed not active when the input voltage is less than 50 Vrms or the duration is less than 250 ms. A

Special Function input is undefined by these specifications and may or may not be sensed active when the input voltage is between 50 Vrms and 70 Vrms or the duration is between 250 ms and 550 ms.

Ensure the conflict monitor recognizes field signal inputs for each channel that meet the following requirements:

- consider a Red input greater than 70 Vrms and with a duration of at least 500 ms as an “on” condition;
- consider a Red input less than 50 Vrms or with a duration of less than 200 ms as an “off” condition (no valid signal);
- consider a Red input between 50 Vrms and 70 Vrms or with a duration between 200 ms and 500 ms to be undefined by these specifications;
- consider a Green or Yellow input greater than 25 Vrms and with a duration of at least 500 ms as an “on” condition;
- consider a Green or Yellow input less than 15 Vrms or with a duration of less than 200 ms as an “off” condition; and
- consider a Green or Yellow input between 15 Vrms and 25 Vrms or with a duration between 200 ms and 500 ms to be undefined by these specifications.

Provide a conflict monitor that recognizes the faults specified by CALTRANS’ 2009 TEES and the following additional faults. Ensure the conflict monitor will trigger upon detection of a fault and will remain in the triggered (in fault mode) state until the unit is reset at the front panel or through the external remote reset input for the following failures:

1. **Red Monitoring or Absence of Any Indication (Red Failure):** A condition in which no “on” voltage signal is detected on any of the green, yellow, or red inputs to a given monitor channel. If a signal is not detected on at least one input (R, Y, or G) of a conflict monitor channel for a period greater than 1000 ms when used with a 170 controller and 1500 ms when used with a 2070 controller, ensure monitor will trigger and put the intersection into flash. If the absence of any indication condition lasts less than 700 ms when used with a 170 controller and 1200 ms when used with a 2070 controller, ensure conflict monitor will not trigger. Red fail monitoring shall be enabled on a per channel basis by the use of switches located on the conflict monitor. Have red monitoring occur when all of the following input conditions are in effect:
 - a) Red Enable input to monitor is active (Red Enable voltages are “on” at greater than 70 Vrms, off at less than 50 Vrms, undefined between 50 and 70 Vrms), and
 - b) Neither Special Function 1 nor Special Function 2 inputs are active.
 - c) Pin #EE (output relay common) is not active
2. **Short/Missing Yellow Indication Fault (Clearance Error):** Yellow indication following a green is missing or shorter than 2.7 seconds (with ± 0.1 -second accuracy). If a channel fails to detect an “on” signal at the Yellow input for a minimum of 2.7 seconds (± 0.1 second) following the detection of an “on” signal at a Green input for that channel, ensure that the monitor triggers and generates a clearance/short yellow error fault indication. Short/missing yellow (clearance) monitoring shall be enabled on a per channel basis by the use of switches located on the conflict

monitor. This fault shall not occur when the channel is programmed for Yellow Inhibit, when the Red Enable signal is inactive or pin #EE (output relay common) is active.

3. **Dual Indications on the Same Channel:** In this condition, more than one indication (R,Y,G) is detected as “on” at the same time on the same channel. If dual indications are detected for a period greater than 500 ms, ensure that the conflict monitor triggers and displays the proper failure indication (Dual Ind fault). If this condition is detected for less than 200 ms, ensure that the monitor does not trigger. G-Y-R dual indication monitoring shall be enabled on a per channel basis by the use of switches located on the conflict monitor. G-Y dual indication monitoring shall be enabled for all channels by use of a switch located on the conflict monitor. This fault shall not occur when the Red Enable signal is inactive or pin #EE (output relay common) is active.
4. **Configuration Settings Change:** The configuration settings are comprised of (as a minimum) the permissive diode matrix, dual indication switches, yellow disable jumpers, any option switches, any option jumpers, and the Watchdog Enable switch. Ensure the conflict monitor compares the current configuration settings with the previous stored configuration settings on power-up, on reset, and periodically during operation. If any of the configuration settings are changed, ensure that the conflict monitor triggers and causes the program card indicator to flash. Ensure that configuration change faults are only reset by depressing and holding the front panel reset button for a minimum of three seconds. Ensure the external remote reset input does not reset configuration change faults.

Ensure the conflict monitor will trigger and the AC Power indicator will flash at a rate of $2 \text{ Hz} \pm 20\%$ with a 50% duty cycle when the AC Line voltage falls below the “drop-out” level. Ensure the conflict monitor will resume normal operation when the AC Line voltage returns above the “restore” level. Ensure the AC Power indicator will remain illuminated when the AC voltage returns above the “restore” level. Should an AC Line power interruption occur while the monitor is in the fault mode, then upon restoration of AC Line power, the monitor will remain in the fault mode and the correct fault and channel indicators will be displayed.

Provide a flash interval of at least 6 seconds and at most 16 seconds in duration following a power-up, an AC Line interruption, or a brownout restore. Ensure the conflict monitor will suspend all fault monitoring functions, close the Output relay contacts, and flash the AC indicator at a rate of $4 \text{ Hz} \pm 20\%$ with a 50% duty cycle during this interval. Ensure the termination of the flash interval after at least 6 seconds if the Watchdog input has made 5 transitions between the True and False state and the AC Line voltage is greater than the “restore” level. If the watchdog input has not made 5 transitions between the True and False state within 10 ± 0.5 seconds, the monitor shall enter a WDT error fault condition.

Ensure the conflict monitor will monitor an intersection with a minimum of four approaches using the four-section Flashing Yellow Arrow (FYA) vehicle traffic signal as outlined by the NCHRP 3-54 research project for protected-permissive left turn signal displays. Ensure the conflict monitor will operate in the FYA mode and FYAc (Compact) mode as specified below to monitor each channel pair for the following fault conditions: Conflict, Flash Rate Detection, Red Fail, Dual Indication, and Clearance. Provide a switch to select between the FYA mode and FYAc mode. Provide a switch to select each FYA phase movement for monitoring.

FYA mode

| FYA Signal Head | Phase 1 | Phase 3 | Phase 5 | Phase 7 |
|-----------------------|------------------|-------------------|-------------------|-------------------|
| Red Arrow | Channel 9 Red | Channel 10 Red | Channel 11 Red | Channel 12 Red |
| Yellow Arrow | Channel 9 Yellow | Channel 10 Yellow | Channel 11 Yellow | Channel 12 Yellow |
| Flashing Yellow Arrow | Channel 9 Green | Channel 10 Green | Channel 11 Green | Channel 12 Green |
| Green Arrow | Channel 1 Green | Channel 3 Green | Channel 5 Green | Channel 7 Green |

FYAc mode

| FYA Signal Head | Phase 1 | Phase 3 | Phase 5 | Phase 7 |
|-----------------------|------------------|------------------|------------------|-------------------|
| Red Arrow | Channel 1 Red | Channel 3 Red | Channel 5 Red | Channel 7 Red |
| Yellow Arrow | Channel 1 Yellow | Channel 3 Yellow | Channel 5 Yellow | Channel 7 Yellow |
| Flashing Yellow Arrow | Channel 1 Green | Channel 3 Green | Channel 5 Green | Channel 7 Green |
| Green Arrow | Channel 9 Green | Channel 9 Yellow | Channel 10 Green | Channel 10 Yellow |

If a FYA channel pair is enabled for FYA operation, the conflict monitor will monitor the FYA logical channel pair for the additional following conditions:

1. **Conflict:** Channel conflicts are detected based on the permissive programming jumpers on the program card. This operation remains unchanged from normal operation except for the solid Yellow arrow (FYA clearance) signal.
2. **Yellow Change Interval Conflict:** During the Yellow change interval of the Permissive Turn channel (flashing Yellow arrow) the conflict monitor shall verify that no conflicting channels to the solid Yellow arrow channel (clearance) are active. These conflicting channels shall be determined by the program card compatibility programming of the Permissive Turn channel (flashing Yellow arrow). During the Yellow change interval of the Protected Turn channel (solid Green arrow) the conflict monitor shall verify that no conflicting channels to the solid Yellow arrow channel (clearance) are active as determined by the program card compatibility programming of the Protected Turn channel (solid Green arrow).
3. **Flash Rate Detection:** The conflict monitor unit shall monitor for the absence of a valid flash rate for the Permissive turn channel (flashing Yellow arrow). If the Permissive turn channel (flashing Yellow arrow) is active for a period greater than 1600 milliseconds, ensure the conflict monitor triggers and puts the intersection into flash. If the Permissive turn channel (flashing

Yellow arrow) is active for a period less than 1400 milliseconds, ensure the conflict monitor does not trigger. Ensure the conflict monitor will remain in the triggered (in fault mode) state until the unit is reset at the front panel or through the external remote reset input. Provide a jumper or switch that will enable and disable the Flash Rate Detection function. Ensure that when the jumper is not present or the switch is in the OFF position the Flash Rate Detection function is enabled. Ensure that when the jumper is present or the switch is in the ON position the Flash Rate Detection function is disabled.

4. **Red Monitoring or Absence of Any Indication (Red Failure):** The conflict monitor unit shall detect a red failure if there is an absence of voltage on all four of the inputs of a FYA channel pair (RA, YA, FYA, GA).
5. **Dual Indications on the Same Channel:** The conflict monitor unit shall detect a dual indication if two or more inputs of a FYA channel pair (RA, YA, FYA, GA) are “on” at the same time.
6. **Short/Missing Yellow Indication Fault (Clearance Error):** The conflict monitor unit shall monitor the solid Yellow arrow for a clearance fault when terminating both the Protected Turn channel (solid Green arrow) interval and the Permissive Turn channel (flashing Yellow arrow) interval.

Ensure that the conflict monitor will log at least nine of the most recent events detected by the monitor in non-volatile EEPROM memory (or equivalent). For each event, record at a minimum the time, date, type of event, status of each field signal indication with RMS voltage, and specific channels involved with the event. Ensure the conflict monitor will log the following events: monitor reset, configuration, previous fault, and AC line. Furnish the signal sequence log that shows all channel states (Greens, Yellows, and Reds) and the Red Enable State for a minimum of 2 seconds prior to the current fault trigger point. Ensure the display resolution of the inputs for the signal sequence log is not greater than 50 ms.

For conflict monitors used within an Ethernet communications system, provide a conflict monitor with an Ethernet 10/100 Mbps, RJ-45 port for data communication access to the monitor by a local notebook computer and remotely via a workstation or notebook computer device connected to the signal system local area network. The Ethernet port shall be electrically isolated from the conflict monitor's electronics and shall provide a minimum of 1500 Vrms isolation. Integrate monitor with Ethernet network in cabinet. Provide software to retrieve the time and date from a network server in order to synchronize the on-board times between the conflict monitor and the controller. Furnish and install the following Windows based, graphic user interface software on workstations and notebook computers where the signal system client software is installed: 1) software to view and retrieve all event log information, 2) software that will search and display a list of conflict monitor IP addresses and IDs on the network, and 3) software to change the conflict monitor's network parameters such as IP address and subnet mask.

For non-Ethernet connected monitors, provide a RS-232C/D compliant port (DB-9 female connector) on the front panel of the conflict monitor in order to provide communications from the conflict monitor to the 170/2070 controller or to a Department-furnished laptop computer. Electrically isolate the port interface electronics from all monitor electronics, excluding Chassis Ground. Ensure that the controller can receive all event log information through a controller Asynchronous Communications Interface Adapter (Type 170E) or Async Serial Comm Module (2070). Furnish and connect a serial cable from the conflict monitor's DB-9 connector to Comm Port 1 of the 2070 controller. Ensure conflict monitor communicates with the controller. Provide a Windows based graphic user interface software to communicate directly through the same monitor RS-232C/D

compliant port to retrieve and view all event log information to a Department-furnished laptop computer. The RS-232C/D compliant port on the monitor shall allow the monitor to function as a DCE device with pin connections as follows:

| Conflict Monitor RS-232C/D (DB-9 Female) Pinout | | |
|--|-----------------|------------|
| Pin Number | Function | I/O |
| 1 | DCD | O |
| 2 | TX Data | O |
| 3 | RX Data | I |
| 4 | DTR | I |
| 5 | Ground | - |
| 6 | DSR | O |
| 7 | CTS | I |
| 8 | RTS | O |
| 9 | NC | - |

MONITOR BOARD EDGE CONNECTOR

| Pin # | Function (Back Side) | Pin # | Function (Component Side) |
|--------------|-----------------------------|--------------|----------------------------------|
| 1 | Channel 2 Green | A | Channel 2 Yellow |
| 2 | Channel 13 Green | B | Channel 6 Green |
| 3 | Channel 6 Yellow | C | Channel 15 Green |
| 4 | Channel 4 Green | D | Channel 4 Yellow |
| 5 | Channel 14 Green | E | Channel 8 Green |
| 6 | Channel 8 Yellow | F | Channel 16 Green |
| 7 | Channel 5 Green | H | Channel 5 Yellow |
| 8 | Channel 13 Yellow | J | Channel 1 Green |
| 9 | Channel 1 Yellow | K | Channel 15 Yellow |
| 10 | Channel 7 Green | L | Channel 7 Yellow |
| 11 | Channel 14 Yellow | M | Channel 3 Green |
| 12 | Channel 3 Yellow | N | Channel 16 Yellow |
| 13 | Channel 9 Green | P | Channel 17 Yellow |
| 14 | Channel 17 Green | R | Channel 10 Green |
| 15 | Channel 11 Yellow | S | Channel 11 Green |
| 16 | Channel 9 Yellow | T | Channel 18 Yellow |
| 17 | Channel 18 Green | U | Channel 10 Yellow |
| -- | | -- | |
| 18 | Channel 12 Yellow | V | Channel 12 Green |
| 19 | Channel 17 Red | W | Channel 18 Red |
| 20 | Chassis Ground | X | Not Assigned |
| 21 | AC- | Y | DC Common |
| 22 | Watchdog Timer | Z | External Test Reset |
| 23 | +24VDC | AA | +24VDC |
| 24 | Tied to Pin 25 | BB | Stop Time (Output) |
| 25 | Tied to Pin 24 | CC | Not Assigned |
| 26 | Not Assigned | DD | Not Assigned |
| 27 | Relay Output, Side #3, N.O. | EE | Relay Output, Side #2, Common |
| 28 | Relay Output, Side #1, N.C. | FF | AC+ |

-- Slotted for keying between Pins 17/U and 18/V

CONFLICT PROGRAM CARD PIN ASSIGNMENTS

| Pin # | Function (Back Side) | Pin # | Function (Component Side) |
|--------------|-----------------------------|--------------|----------------------------------|
| 1 | Channel 2 Green | A | Channel 1 Green |
| 2 | Channel 3 Green | B | Channel 2 Green |
| 3 | Channel 4 Green | C | Channel 3 Green |
| 4 | Channel 5 Green | D | Channel 4 Green |
| 5 | Channel 6 Green | E | Channel 5 Green |
| 6 | Channel 7 Green | F | Channel 6 Green |
| 7 | Channel 8 Green | H | Channel 7 Green |
| 8 | Channel 9 Green | J | Channel 8 Green |
| 9 | Channel 10 Green | K | Channel 9 Green |
| 10 | Channel 11 Green | L | Channel 10 Green |
| 11 | Channel 12 Green | M | Channel 11 Green |
| 12 | Channel 13 Green | N | Channel 12 Green |
| 13 | Channel 14 Green | P | Channel 13 Green |
| 14 | Channel 15 Green | R | Channel 14 Green |
| 15 | Channel 16 Green | S | Channel 15 Green |
| 16 | N/C | T | PC AJAR |
| 17 | Channel 1 Yellow | U | Channel 9 Yellow |
| 18 | Channel 2 Yellow | V | Channel 10 Yellow |
| 19 | Channel 3 Yellow | W | Channel 11 Yellow |
| 20 | Channel 4 Yellow | X | Channel 12 Yellow |
| 21 | Channel 5 Yellow | Y | Channel 13 Yellow |
| 22 | Channel 6 Yellow | Z | Channel 14 Yellow |
| 23 | Channel 7 Yellow | AA | Channel 15 Yellow |
| 24 | Channel 8 Yellow | BB | Channel 16 Yellow |
| -- | | -- | |
| 25 | Channel 17 Green | CC | Channel 17 Yellow |
| 26 | Channel 18 Green | DD | Channel 18 Yellow |
| 27 | Channel 16 Green | EE | PC AJAR (Program Card) |
| 28 | Yellow Inhibit Common | FF | Channel 17 Green |

-- Slotted for keying between Pins 24/BB and 25/CC

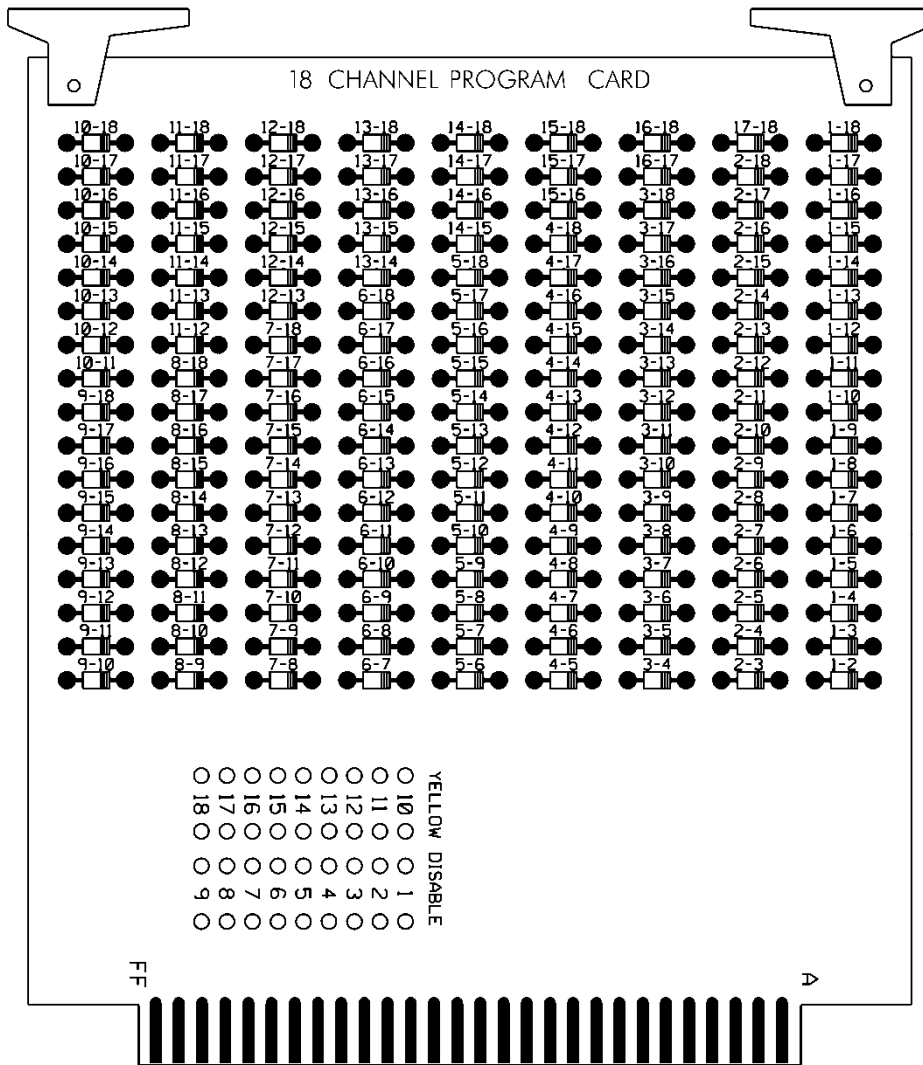

2.4. MATERIALS – TYPE 170 DETECTOR SENSOR UNITS

Furnish detector sensor units that comply with Chapter 5 Section 1, “General Requirements,” and Chapter 5 Section 2, “Model 222 & 224 Loop Detector Sensor Unit Requirements,” of the CALTRANS “Transportation Electrical Equipment Specifications” dated March 12, 2009 with Erratum 1.

2.5. CONSTRUCTION METHODS

Furnish and install Type 2070LX Controllers in existing cabinets when work begins as shown in the plans at the following locations:

- 09-0734 – NC 8 at US 29 NB/US 64-70 EB Ramp
- 09-0735 – NC 8 at US 29 SB/US 64-70 WB Ramp during deployment of Temporary Signal Plan 1
- 09-0402 – NC 8 at 9th St during deployment of Temporary Phase 1
- 09-0400 – NC 8 at SR 1408 (Biesecker Rd) during deployment of Temporary Phase 1
- 09-1325 – NC 8 at Walser Rd

Furnish and install a Type 270LX Controller and Cabinet as shown in the plans at the following location:

09-0401 – NC 8 at 11th St during deployment of Temporary Signal Plan 1

Relocate 2070LX controllers installed in Temporary Phase 1 to new cabinets as shown in the plans at the following locations:

09-0402 - NC 8 at 9th St during deployment of Temporary Signal Plan 2

09-0400 – NC 8 at SR 1408 (Biesecker Rd) during deployment of the Final Signal Design

2.6. MEASUREMENT AND PAYMENT

2070LX Controller will be measured and paid as the actual number of 2070LX Controllers furnished, installed, relocated, and accepted.

Cabinet Without Controller (332) will be measured and paid as the actual number of 332 cabinets furnished, installed, and accepted.

No measurement will be made for relocating 2070LX Controllers from existing cabinets to new cabinets as this will be incidental to the Pay Item for *Controller (2070LX)*.

Payment will be made under:

| | |
|--|------|
| 2070LX Controller | Each |
| Cabinet Without Controller (332) | Each |

3. VIDEO IMAGING LOOP EMULATOR DETECTOR SYSTEMS FOR TEMPORARY INSTALLATION

3.1. DESCRIPTION

Design, furnish, provide training, and install video imaging loop emulator detection systems with all necessary hardware for temporary traffic signals in accordance with the plans and specifications.

Unless otherwise specified in the contract, all loop emulator detection equipment will remain the property of the contractor.

3.2. MATERIALS

A. General:

Material and equipment furnished under this section must be pre-approved on the Department’s QPL by the date of installation except miscellaneous hardware such as cables and mounting hardware do not need to be pre-approved.

Used equipment will be acceptable provided the following conditions have been met:

- Equipment is listed on the current QPL.
- Equipment is in good working condition.
- Equipment is to remain the property of the contractor.

Ensure that software is licensed for use by the Department and by any other agency responsible for maintaining or operating the loop emulation system. Provide the Department with a license to duplicate and distribute the software as necessary for design and maintenance support.

Design and furnish video imaging loop emulator detection systems that detect vehicles at signalized intersections by processing video images and providing detection outputs to the signal controller in real time (within 112 milliseconds of vehicle arrival).

Furnish all required camera sensor units, loop emulator processor units, hardware and software packages, cabling, poles, mast arms, harnesses, camera mounting assemblies, surge protection panels, grounding systems, messenger cable and all necessary hardware. Furnish systems that allow the display of detection zones superimposed on an image of the roadway on a Department-furnished monitor or laptop computer screen. Ensure detection zones can be defined and data entered using a simple keyboard or mouse and monitor, or using a laptop PC with software.

Provide design drawings showing design details and camera sensor unit locations for review and acceptance before installation. Provide mounting height and location requirements for camera sensor units on the design based on site survey. Design video imaging loop emulator detection systems with all necessary hardware. Indicate all necessary poles, spans, mast arms, luminaire arms, cables, camera mounting assemblies and hardware to achieve the required detection zones where Department owned poles are not adequate to locate the camera sensor units. Do not design for the installation of poles in medians.

Obtain the Engineer's approval before furnishing video imaging loop emulator detection systems. The contractor is responsible for the final design of video imaging loop emulator detection systems. Review and acceptance of the designs by the Department does not relieve the contractor from the responsibility to provide fully functional systems and to ensure that the required detection zones can be provided.

Provide the ability to program each detection call (input to the controller) with the following functions:

- Full Time Delay – Delay timer is active continuously,
- Normal Delay – Delay timer is inhibited when assigned phase is green (except when used with TS 2 and 170/2070L controllers),
- Extend – Call is extended for this amount of time after vehicle leaves detection area,
- Delay Call/Extend Call – This feature uses a combination of full time delay and extend time on the same detection call. Ensure operation is as follows: Vehicle calls are received after the delay timer times out. When a call is detected, it is held until the detection area is empty and the programmed extend time expires. If another vehicle enters the detection area before the extend timer times out, the call is held and the extend time is reset. When the extend timer times out, the delay timer has to expire before another vehicle call can be received.

Provide the ability to program each detection zone as one of the following functions:

- Presence detector,
- Directional presence detector,
- Pulse detector,
- Directional pulse detector.

Ensure previously defined detector zones and configurations can be edited.

Provide each individual system with all the necessary equipment to focus and zoom the camera lenses without the need to enter the camera enclosure.

Provide systems that allow for the placement of at least 8 detection zones within the combined field of view of a single camera sensor unit. Provide a minimum of 8 detection outputs per camera.

Provide detection zones that can be overlapped. Ensure systems reliably detect vehicles when the horizontal distance from the camera sensor unit to the detection zone area is less than ten times the mounting height of the sensor. Ensure systems detect vehicles in multiple travel lanes.

Ensure systems can detect vehicle presence within a 98 to 102 percent accuracy (up to 2 percent of the vehicles missed and up to 2 percent of false detection) for clear, dry, daylight conditions, a 96 to 105 percent accuracy (up to 4 percent of the vehicles missed and up to 5 percent false detection) for dawn and dusk conditions, and a 96 percent accuracy (up to 4 percent of the vehicles missed) for night and adverse conditions (fog, snow, rain, etc.) using standard sensor optics and in the absence of occlusion.

Repair and replace all failed components within 72 hours.

The Department may conduct field-testing to ensure the accuracy of completed video imaging loop emulator detection systems.

B. Loop Emulator System:

Furnish loop emulator systems that receive and simultaneously process information from camera sensor units, and provides detector outputs to signal controllers.

Ensure systems provide the following:

- Operate in a typical roadside environment and meet the environmental specifications and are fully compatible with NEMA TS 1, NEMA TS 2, or Type 170/2070L controllers and cabinets,
- provide a “fail-safe” mode whereby failure of one or more of the camera sensor units or power failure of the loop emulator system will cause constant calls to be placed on the affected vehicle detection outputs to the signal controller,
- provide compensation for minor camera movement of up to 2 percent of the field of view at 400 feet without falsely detecting vehicles,
- process the video at a minimum rate of 30 times per second,
- provide separate wired connectors inside the controller cabinet for video recording each camera,
- provide remote video monitoring with a minimum refresh rate at 1 frame per second over a standard dial-up telephone line,
- provide remote video detection monitoring.

Furnish camera sensor units that comply with the following:

- have an output signal conforming to EIA RS-170 standard,
- have a nominal output impedance of 75 ohms,
- be immune to bright light sources, or have built in circuitry or protective devices to prevent damage to the sensor when pointed directly at strong light sources,
- be housed in a light colored environmental enclosure that is water proof and dust tight, and that conforms to NEMA-4 specifications or better,
- simultaneously monitor at least five travel lanes when placed at the proper mounting location with a zoom lens,
- have a sunshield attached to the environmental enclosure to minimize solar heating,
- meet FCC class B requirements for electromagnetic interference emissions,
- have a heater attached to the viewing window of the environmental enclosure to prevent ice and condensation in cold weather.

Where coaxial video cables and other cables are required between the camera sensor and other components located in the controller cabinet, furnish surge protection in the controller cabinet.

If furnishing coaxial communications cable comply with the following, as recommended by the approved loop emulator manufacturer:

- Number 20 AWG, solid bare copper conductor terminated with crimped-on BNC connectors (do not use BNC adapters) from the camera sensor to the signal controller cabinet.
- Number 22 AWG, stranded bare copper conductor terminated with crimped-on BNC connectors (do not use BNC adapters) from the camera sensor unit to the junction box, and within the signal controller cabinet.

Furnish power cable appropriately sized to meet the power requirements of the sensors. At a minimum, provide three conductor 120 VAC field power cable.

As determined during the site survey, furnish sensor junction boxes with nominal 6 x 10 x 6 inches dimensions at each sensor location. Provide terminal blocks and tie points for coaxial cable.

C. Video Imaging Loop Emulator System Support:

Furnish video imaging loop emulator systems with either a simple keyboard or a mouse with monitor and appropriate software, or with system software for use on department-owned laptop PCs. Ensure the system is Windows 2000 and Windows XP compatible.

Provide Windows 2000 and Windows XP compatible personal computer software, if needed, to provide remote video and video detection monitoring.

Ensure systems allow the user to edit previously defined detector configurations. When a vehicle is within a detection zone, provide for a change in color or intensity of the detection zone perimeter or other appropriate display changes on the Department-furnished monitor or laptop computer screen.

Provide cabling and interconnection hardware with 6-foot minimum length interconnection cable to interface with the system.

Provide all associated equipment manuals and documentation.

3.3. CONSTRUCTION METHODS

Arrange and conduct site surveys with the system manufacturer's representative and Department personnel to determine proper camera sensor unit selection and placement. Provide the Department at least 3 working days notice before conducting site surveys. Upon completion of the site surveys the Department will provide revised plans reflecting the findings of the site survey.

Before beginning work at locations requiring video imaging loop emulator detection systems, furnish system software. Upon activation of detection zones, provide detector configuration files. Ensure that up-to-date detection configuration files are furnished for various detection zone configurations that may be required for construction phasing.

Place into operation loop emulator detection systems. Configure loop emulator detection systems to achieve required detection in designated zones. Have a certified manufacturer's representative on site to supervise and assist with installation, set up, and testing of the system.

Install the necessary processing and communications equipment in the signal controller cabinet. Make all necessary modifications to install equipment, cabling harnesses, and camera sensor interface panels with surge suppression.

Perform modifications to camera sensor unit gain, sensitivity, and iris limits necessary to complete the installation.

Do not install camera sensor units on signal poles unless approved by the Engineer.

Install the necessary cables from each sensor to the signal controller cabinet along signal cabling routes. Install surge protection and terminate all cable conductors.

Reconfigure detection zones as necessary according to the plans for construction phases.

Provide at least 8 hours of training on the set up, operation, troubleshooting, and maintenance of the loop emulator detection system to a maximum of ten Department personnel. Arrange for training to be conducted by the manufacturer’s representative at an approved site within the Division responsible for administration of the project. Thirty days before conducting training submit a detailed course curriculum, draft manuals and materials, and resumes. Obtain approval of the submittal before conducting the training. At least one week before beginning training, provide three sets of complete documentation necessary to maintain and operate the system. Do not perform training until installation of loop emulator detection systems is complete.

3.4. MEASUREMENT AND PAYMENT

Actual number of site surveys, arranged, conducted, and accepted.

Actual number of luminaire arms for temporary video systems furnished, installed, and accepted.

Actual number of cameras without internal loop emulator processing units furnished, installed, and accepted.

Actual number of external loop emulator processing units furnished, installed, and accepted.

No measurement will be made of video imaging loop emulator system support or training, power and video cables, and trenching as these items will be considered incidental to furnishing and installing video imaging loop emulator detection systems.

Payment will be made under:

| | |
|---|------|
| Site Survey | Each |
| Luminaire Arm for Temporary Video System | Each |
| Camera without Internal Loop Emulator Processing Unit | Each |
| External Loop Emulator Processing Unit..... | Each |

4. METAL POLE SUPPORTS

4.1. METAL POLES

A. General:

Furnish and install metal poles, grounding systems, and all necessary hardware. Work covered under this special provision includes requirements for design, fabrication, and installation of standard and custom/site-specific designed metal pole supports and associated foundations.

Comply with applicable sections of the *2024 STANDARD SPECIFICATIONS FOR ROADS & STRUCTURES*, hereinafter referred to as the *Standard Specifications*. Provide designs of completed assemblies with hardware equaling or exceeding *AASHTO LRFD Specifications for Structural Supports for Highway Signs, Luminaires and Traffic Signals* 1st Edition, 2015 (hereinafter called 1st Edition AASHTO), including the latest interim specifications. Provide assemblies with a round or near-round (18 sides or more) cross-section, or a multi-sided cross section with no less than six sides. The sides may be straight, convex, or concave.

For bid purposes, pole heights shown on plans are estimated from available data. Prior to furnishing metal poles, use field measurements and adjusted cross-sections to determine whether pole heights will meet required clearances. If pole heights do not meet required clearances, the Contractor should immediately notify the Engineer of the required revised pole heights.

Standard Drawings for Metal Poles are available that supplement these project special provisions. The drawings are located on the Department’s website:

<https://connect.ncdot.gov/resources/safety/pages/ITS-Design-Resources.aspx>

Comply with article 1098-1(B) of the *Standard Specifications* for submittal requirements. Furnish shop drawings for approval. Provide copies of detailed shop drawings for each type of structure as summarized below. Ensure shop drawings include material specifications for each component. Ensure shop drawings identify welds by type and size on the detail drawing only, not in table format. **Do not release structures for fabrication until shop drawings have been approved by NCDOT.** Ensure shop drawings contain an itemized bill of materials for all structural components and associated connecting hardware.

Comply with article 1098-1(A) of the *Standard Specifications* for Qualified Products List (QPL) submittals. All shop drawings must include project location description, signal or asset inventory number(s) and project number or work order number.

Summary of information required for metal pole review submittal:

| Item | Electronic Submittal | Comments / Special Instructions |
|---|----------------------|---|
| Sealed, Approved Signal or ITS Plan/Loading Diagram | 1 set | All structure design information needs to reflect the latest approved Signal or ITS plans |
| Custom Pole Shop Drawings | 1 set | Submit drawings on 11" x 17" format media. Show NCDOT signal or asset inventory number(s), Contractor's name and relevant revision number in the title block. All drawings must have a <u>unique drawing number</u> for each project. |
| Standard Strain Pole Shop Drawings (from the QPL) | 1 set | Submit drawings on 11" x 17" format media. Show NCDOT signal inventory number(s), Contractor's name and relevant revision number in the title block. All drawings must have a <u>unique drawing number</u> for each project. |
| Structure Calculations | 1 set | Not required for Standard QPL Poles |
| Standard Strain Pole Foundation Drawings | 1 set | Submit drawings on 11" x 17" format media. Submit a completed Standard Foundation Selection form for each pole using foundation table on Metal Pole Drawing M8. |
| Custom Foundation Drawings | 1 set | Submit drawings on 11" x 17" format media. Show NCDOT signal or asset inventory number(s), Contractor's name and relevant revision number in the title block. All drawings must have a <u>unique drawing number</u> for each project. If QPL Poles are used, include the corresponding QPL pole shop drawings with this submittal. |
| Foundation Calculations | 1 set | Submit copies of LPILE input, output, and pile tip deflection graph per Section titled Drilled Pier Foundations for Metal Poles of this specification for each foundation. Not required for Standard Strain Poles (from the QPL) |
| Soil Boring Logs and Report | 1 set | Report shall include a location plan and a soil classification report including soil capacity, water level, hammer efficiency, soil bearing pressure, soil density, etc. for each pole. |

NOTE – All shop drawings and custom foundation design drawings must be sealed by a Professional Engineer licensed in the state of North Carolina. All geotechnical information must be sealed by either a Professional Engineer or Geologist licensed in the state of North Carolina. Include a title block and revision block on the shop drawings and foundation drawings showing the NCDOT signal or asset inventory number(s).

Shop drawings and foundation drawings may be submitted together or separately for approval. However, shop drawings must be approved before foundations can be reviewed.

Foundation designs will be returned without review if the associated shop drawing has not been approved. Boring reports shall include the following: Engineer's summary, boring location maps, soil classification per AASHTO Classification System, hammer efficiency, and Metal Pole Standard Foundation Selection Form. Incomplete submittals will be returned without review. The Reviewer has the right to request additional analysis and copies of the calculations to expedite the approval process.

B. Materials:

Fabricate metal pole from coil or plate steel that meet the requirements of ASTM A 572 Gr 55 or ASTM A 595 Grade A tubes. For structural steel shapes, plates, and bars use, as a minimum, ASTM A572 Gr 50, AASHTO M270 Gr 50, ASTM A709 Gr 50, or an approved equivalent. Provide pole shafts of round or near round (18 sides or more) cross-section, or multi-sided tubular cross-section with no less than six sides, having a uniform linear taper of 0.14 in/ft. Construct shafts from one piece of single-ply plate or coil. For anchor base fabrication, conform to the applicable bolt pattern and orientation as shown on Metal Pole Standard Drawing Sheet M2.

Use the submerged arc process, or other NCDOT previously approved process suitable for shafts, to continuously weld pole shafts along their entire length. Finish the longitudinal seam weld flush with the outside contour of the base metal. Ensure shaft has no circumferential welds except at the lower end joining the shaft to the pole base. Use full penetration groove welds with backing ring for all tube-to-transverse-plate connections in accordance with 1st Edition AASHTO. Provide welding that conforms to Article 1072-18 of the *Standard Specifications*. No field welding on any part of the pole will be permitted unless approved by a qualified Engineer.

After fabrication, hot-dip galvanize steel poles and all assembly components in accordance with section 1076-3 of the *Standard Specifications*. Design structural assemblies with weep holes large enough and properly located to drain molten zinc during the galvanization process. Galvanize hardware in accordance with section 1076-4 of the *Standard Specifications*. Ensure threaded material is brushed and retapped as necessary after galvanizing. Perform repair of damaged galvanizing in accordance with section 1076-7 of the *Standard Specifications*. Ensure all hardware is galvanized steel or stainless steel. The Contractor is responsible for ensuring the Designer/Fabricator specifies connecting hardware and/or materials that prevent a dissimilar metal corrosive reaction.

Ensure each anchor rod is 2-inch minimum diameter and 60-inch length. Provide 10-inch minimum thread projection at the top of the rod, and 8-inch minimum at the bottom of the rod. Use anchor rod assembly and drilled pier foundation materials complying with SP09_R005, hereinafter referred to as *Foundations and Anchor Rod Assemblies for Metal Poles*.

Ensure anchor bolt hole diameters are ¼-inch larger than the anchor bolt diameters in the base plate.

Provide a circular anchor bolt lock plate securing the anchor bolts at the embedded end with two (2) washers and two (2) nuts. Provide a base plate template matching the bolt circle diameter of the anchor bolt lock plate. Construct plates and templates from ¼-inch minimum thick steel with a minimum width of 4 inches. Hot-dip galvanizing is not required for both plates.

Provide four (4) heavy hex nuts and four (4) flat washers for each anchor bolt. For nuts, use AASHTO M291 grade 2H, DH, or DH3 or equivalent material. For flat washers, use AASHTO M293 or equivalent material. Ensure anchor bolts have required diameters, lengths, and positions, and will develop strengths comparable to their respective poles.

For each pole, provide a grounding lug with a ½-inch minimum thread diameter, coarse thread stud and nut that will accommodate #4 AWG ground wire. Ensure the lug is electrically bonded to the pole and is conveniently located inside the pole at the hand hole.

Provide a removable pole cap with stainless steel attachment screws for the top of each pole. Ensure cap is cast aluminum conforming to Aluminum Association Alloy 356.0F. Furnish cap attached to the pole with a sturdy stainless-steel chain that is long enough to permit cap to hang clear of the pole-top opening when cap is removed.

Where required by the plans, furnish couplings 42 inches above bottom of the pole base for mounting of pedestrian pushbuttons. Provide mounting points consisting of 1½-inch internally threaded half-couplings complying with the NEC, mounted within the poles. Ensure that couplings are essentially flush with the outside surfaces of the poles and are installed before any required hot-dip galvanizing. Provide a threaded plug in each mounting point. Ensure the surface of the plug is essentially flush with the outer end of the mounting point when installed and has a recessed slot that will accommodate a ½ “drive standard socket wrench.

Metal poles may be erected and fully loaded after concrete has attained a minimum allowable compressive strength of 3,000 psi.

Connect poles to grounding electrodes and bond them to the electrical service grounding electrodes.

When field drilling is necessary for wire or cable entrances into the pole, comply with the following requirements:

- Do not drill holes within 2 inches of any welds.
- Do not drill any holes larger than 3 inches in diameter without checking with the ITS & Signals Structure Engineers.
- Avoid drilling multiple holes along the same cross section of tube shafts.
- Install rubber grommets in all field drilled holes that wire, or cable will directly enter unless holes are drilled for installation of weather heads or couplings.
- Treat the inside of the drilled holes and repair all galvanized surfaces in accordance with Section 1076-7 of the latest edition of the *Standard Specification prior to installing grommets, caps, or plugs*.
- Cap or plug any existing field drilled holes that are no longer used with rubber, aluminum, or stainless-steel hole plugs.

When street lighting is installed on metal signal structures, isolate the conductors feeding the luminaires inside the pole shaft using liquid tight flexible metal conduit (Type LFMC), liquid tight flexible nonmetallic conduit (Type LFNC), high density polyethylene conduit (Type HDPE), or approved equivalent. All conductors supplying power for luminaires must run through an external disconnect prior to entrance into the structure. In accordance with the National Electrical Code (NEC) Article 230.2(E), provide identification of the electrical source provider for the luminaire feeder circuit with contact information on a permanent label located in the pole hand hole near the feeder circuit raceway.

Install a ¼-inch thick plate for a concrete foundation tag to include the following information: concrete grade, depth, diameter, and reinforcement sizes of the installed foundation. Install galvanized wire mesh to cover gap between the base plate and top of foundation for debris and pest control. Refer to standard drawing M7 for further details.

Immediately notify the Engineer of any structural deficiency that becomes apparent in any assembly, or member of any assembly, because of the design requirements imposed by these specifications, the plans, or the typical drawings.

C. Design:

Unless otherwise specified, design all metal pole support structures using the following 1st Edition AASHTO specifications:

- Use 700-Year MRI and 10-Year MRI wind pressure maps developed from 3-second gust speeds, as provided in Section 3.8.
- Ensure metal pole support structures include natural wind gust loading and truck-induced gust loading for fatigue design, as provided in Sections 11.7.1.2 and 11.7.1.3, respectively. Designs need not consider periodic galloping forces.
- Assume 11.2 mph natural wind gust speed in North Carolina. For natural wind fatigue stress calculations, utilize a drag coefficient (C_d) based on the yearly mean wind velocity of 11.2 mph.
- When selecting Fatigue Importance Factors, utilize Fatigue Importance Category II, as provided for in Table 11.6-1, unless otherwise specified.
- Calculate all forces using applicable equations from Section 5. The Maximum allowable force ratio for all metal pole support designs is 0.9.
- Conform to Sections 10.4.2 and 11.8 for deflection requirements. For CCTV and MVD support structures, ensure maximum deflection at top of pole does not exceed 2.0 percent of pole height.
- Assume the combined minimum weight of a messenger cable bundle (including messenger cable, signal cable and detector lead-in cables) is 1.3 lbs/ft. Assume the combined minimum diameter of the cable bundle is 1.3 inches.
- All CCTV and MVD poles shall meet the compact section limits per section 5.7.2 along with Table 5.7.2-1. Minimum thickness of CCTV and MVD pole shafts shall be ¼-inch.
- All CCTV and MVD poles shall use full-penetration groove weld tube-to-transverse plate connection with backing ring. Refer to Metal Pole Standard Drawing Sheet M9 for details. Fillet-welded tube-to-transverse-plate connections are not permitted.

Unless otherwise specified by special loading criteria, the following computed surface area for ice load on signal heads shall be used:

- 3-section, 12-inch, Surface area: 26.0 ft²
- 4-section, 12-inch, Surface area: 32.0 ft²
- 5-section, 12-inch, Surface area: 42.0 ft²

Design a base plate for each pole. The minimum base plate thickness for all poles is determined by the following criteria:

Case 1 Circular or rectangular solid base plate with the upright pole welded to the top surface of base plate with full penetration butt weld, where no stiffeners are provided. A base plate with a small center hole, which is less than 1/3 of the upright diameter, and located concentrically with the upright pole, may be considered as a solid base plate.

The magnitude of bending moment in the base plate, induced by the anchoring force of each anchor bolt is $M = (P \times D_1) / 2$, where

M = bending moment at the critical section of the base plate induced by one (1) anchor bolt

P = anchoring force of each anchor bolt

D_1 = horizontal distance between the anchor bolt center and the outer face of the upright, or the difference between the bolt circle radius and the outside radius of the upright

Locate the critical section at the face of the anchor bolt and perpendicular to the bolt circle radius. The overlapped part of two (2) adjacent critical sections is considered ineffective.

Case 2 Circular or rectangular base plate with the upright pole socketed into and attached to the base plate with two (2) lines of fillet weld, and where no stiffeners are provided, or any base plate with a center hole that is larger in diameter than 1/3 of the upright diameter.

The magnitude of bending moment induced by the anchoring force of each anchor bolt is $M = P \times D_2$,

where P = anchoring force of each anchor bolt

D_2 = horizontal distance between the face of the upright and the face of the anchor bolt nut

Locate the critical section at the face of the anchor bolt top nut and perpendicular to the radius of the bolt circle. The overlapped part of two (2) adjacent critical sections is considered ineffective.

If the base plate thickness calculated for Case 2 is less than Case 1, use the thickness calculated for Case 1.

The following additional requirements apply concerning pole base plates.

- Ensure that whichever case governs as defined above, the anchor bolt diameter is set to match the base plate thickness. If the minimum diameter required for the anchor bolt exceeds the thickness required for the base plate, set the base plate thickness equal to the required bolt diameter.
- For all metal poles, use a full penetration groove weld with a backing ring to connect the pole upright component to the base. Refer to Metal Pole Standard Drawing Sheet M3 or M4.

The Professional Engineer is wholly responsible for the design of all poles. Review and acceptance of these designs by the Department does not relieve the said Professional Engineer of his or her responsibility.

D. Mast Arm Poles:

Refer to Metal Pole Standard Drawing Sheets M2 through M5 for fabrication details.

Fabricate metal arm shaft from coil or plate steel that meet the requirements of ASTM A 595 Grade A tubes. Provide arm shafts of round or near round (18 sides or more) cross-section, or multi-sided tubular cross-section with no less than six sides, having a uniform linear taper of 0.14 in/ft. Construct shafts from one piece of single-ply plate or coil, eliminating circumferential weld splices.

Use the submerged arc process, or other NCDOT previously approved process suitable for arm shafts, to continuously weld arm shafts along their entire length. The longitudinal seam weld shall be finished flush to the outside contour of the base metal. Ensure arm shaft has no circumferential welds except at the lower end joining the shaft to the arm flange plate. Use full penetration groove welds with backing ring for all tube-to-transverse-plate connections in accordance with 1st Edition AASHTO. Provide welding that conforms to Article 1072-18 of the *Standard Specifications*, except no field welding on any part of the arm shaft will be permitted unless approved by a qualified Engineer.

After fabrication, hot-dip galvanize steel arm shafts and all assembly components per section 1076 of the *Standard Specifications*. Design arm shafts with weep holes large enough and properly located to drain molten zinc during the galvanization process. Provide hot-dip galvanizing on steel arm shafts that meets or exceeds ASTM Standard A-123, AASHTO M111, or an approved equivalent. Perform repair of damaged galvanizing that complies with the following *Standard Specifications* article:

Repair of Galvanizing Article 1076-7

Ensure metal arm shafts permit cables to be installed inside arm shafts. For holes in arm shafts used to accommodate cables, provide full-circumference grommets. Wire access holes for arm flange plates should be deburred, non-grommeted, and oversized to fit around 4-inch diameter grommeted wire access holes for shaft flange plates.

Provide a minimum of four (4) 1-1/2" diameter high strength bolts for connection between arm plate and pole plate. Increase number of bolts to a minimum of six (6) 1-1/2" diameter high strength bolts when arm lengths are greater than 50'-0" long.

Provide designs with a 6" x 12" hand hole with reinforcing frame for each pole.

Provide a terminal compartment with cover and screws in each pole encompassing the hand hole and containing a 12-terminal barrier type terminal block. Provide two (2) terminal screws with a removable shorting bar between them for each termination. Furnish terminal compartment covers attached to the pole by a sturdy chain or cable approved by the Engineer. Ensure chain or cable is long enough to permit cover to hang clear of the compartment opening when cover is removed and is strong enough to prevent vandalism. Ensure chain or cable will not interfere with service to cables in the pole base.

Have poles permanently stamped above the hand holes with the identification tag details as shown on Metal Pole Standard Drawing Sheets M2 and M4.

Provide a removable end cap with stainless steel attachment screws for the end of each mast arm. Ensure cap is cast aluminum conforming to Aluminum Association Alloy 356.0F. Furnish cap attached to arm with a sturdy chain or cable approved by the Engineer. Ensure chain or cable is long enough to permit cap to hang clear of arm end opening when cap is removed.

Provide pole flange plates and associated gussets and fittings for attachment of required mast arms. As part of each mast arm attachment, provide a cable passage hole in pole to allow passage of cables from pole to arm. Provide a grommeted 4-inch diameter cable passage hole on the shaft side of the connection to allow passage of cables from pole to arm.

Furnish all arm plates and necessary attachment hardware, including bolts and brackets.

Provide two (2) extra bolts for each arm.

Provide arms with weatherproof connections for attaching to the pole shaft.

Provide hardware that is galvanized steel, stainless steel, or corrosive-resistant aluminum.

Install metal poles, hardware, and fittings as shown on the manufacturer's installation drawings. Ensure the installed pole, when fully loaded, is within 1 degree 40 minutes (1°40') of vertical. Install poles with the manufacturer's recommended "rake." Where required, use threaded leveling nuts to establish rake.

Install horizontal-type arms with a manufactured rise preventing arm from deflecting below arm attachment height.

Ensure maximum angular rotation of the top of mast arm pole does not exceed 1 degree 40 minutes (1°40'). Ensure allowable mast arm deflection does not exceed that allowed per 1st Edition AASHTO. For all load combination limit states specified under Section 3 of 1st Edition AASHTO, restrict tip of fully loaded arm from going below arm attachment point with the pole.

4.2. DRILLED PIER FOUNDATIONS FOR METAL POLES

Analysis procedures and formulas shall be based on AASHTO 1st Edition, latest ACI-318 code and the *Drilled Shafts: Construction Procedures and Design Methods* FHWA-NHI-10-016 manual. Design methods based on engineering publications or research papers must have prior approval from NCDOT. The Department reserves the right to accept or reject any method used for the analysis.

Ensure deflection at top of foundation does not exceed 1 inch for worst-case (Service Limit State) lateral load.

Use LPILE Plus V6.0 or later for lateral analysis. Submit inputs, results and corresponding graphs with the design calculations.

Calculate skin friction using the α -method for cohesive soils and the β -method for cohesion-less soils (**Broms method will not be accepted**). Detailed descriptions of the “ α ” and “ β ” methods can be found in *FHWA-NHI-10-016*.

Omit first 2.5 feet for cohesive soils when calculating skin friction.

Assume a hammer efficiency of 0.70 unless value is provided.

All CCTV and MVD pole drilled shafts shall be a minimum of 4'-0" diameter. Refer to Standard Drawing Nos. M7 and M8.

Design custom foundations to carry maximum capacity of each metal pole. For standard case strain poles with custom design, use actual shear, axial and moment reactions from the Standard Strain Pole Foundation Selection Table shown on Standard Drawing No. M8.

When poor soil conditions are encountered, which could create an excessively large foundation design, consideration may be given to allow an exemption to the maximum capacity design. The Contractor must gain approval from the Engineer before reducing a foundation's capacity. On projects where poor soil is known to be present, the Contractor should have foundation designs approved before releasing poles for fabrication.

Have the Contractor notify the Engineer if the proposed foundation is to be installed on a slope other than 8H: 1V or flatter.

A. Description:

Furnish and install foundations for NCDOT metal poles with all necessary hardware in accordance with the plans and specifications.

Metal Pole Standards have been developed and implemented by NCDOT for use at signalized intersections in North Carolina. If the plans call for a standard strain pole, then a standard foundation may be selected from the plans. However, the Contractor is not required to use a standard foundation. If the Contractor chooses to design a non-standard site-specific foundation for a standard strain pole or if the plans call for a non-standard site-specific pole, design the foundation to conform to the applicable provisions in the NCDOT Metal Pole Standard Drawings and Section B4 (Non-Standard Foundation Design) below. If non-standard site-specific foundations are designed for standard QPL approved strain poles, the foundation designer must use the design moment specified by load case on Metal Pole Standard Drawing Sheet M8. Failure to conform to this requirement will be grounds for rejection of the design.

If the Contractor chooses to design a non-standard foundation for a standard strain pole and the soil test results indicate a standard foundation is feasible for the site, the Contractor will be paid the cost of the standard foundation. Any additional cost associated with a non-standard site-specific foundation including additional materials, labor and equipment will be considered incidental to the cost of the standard foundation. All costs for the non-standard foundation design will be considered incidental to the cost of the standard foundation.

B. Soil Test and Foundation Determination:

1. General:

Drilled piers are reinforced concrete sections, cast-in-place against in situ, undisturbed material. Drilled piers are of straight shaft type and vertical.

2. Soil Test:

Perform a soil test at each proposed metal pole location. Complete all required fill placement and excavation at each pole location to finished grade before drilling each boring. Soil tests performed that are not in compliance with this requirement may be rejected and will not be paid. Drill one boring to a depth of 26 feet within a 25-foot radius of each proposed foundation.

Perform standard penetration tests (SPT) in accordance with ASTM D 1586 at depths of 1, 2.5, 5, 7.5, 10, 15, 20 and 26 feet. Discontinue the boring if one of the following occurs:

- A total of 100 blows have been applied in any two consecutive 6-inch intervals.
- A total of 50 blows have been applied with < 3-inch penetration.

Describe each pole location along the project corridor in a manner that is easily discernible to both the Contractor’s Designer and NCDOT Reviewers. If the pole is at an intersection, label the boring the “Intersection of (*Route or SR #*), (*Street Name*) and (*Route or SR #*), (*Street Name*), _____ County, Signal or Asset Inventory No. _____”. Label borings with “B- *N, S, E, W, NE, NW, SE or SW*” corresponding to the quadrant location within the intersection.

If the pole location is located between intersections, provide a coordinate location and offset, or milepost number and offset. Pole numbers should be made available to the Drill Contractor. Include pole numbers in the boring label if they are available. If they are not available, ensure the boring labels can be cross-referenced to corresponding pole numbers. For each boring, submit a legible (hand-written or typed) boring log signed and sealed by a licensed Geologist or Professional Engineer registered in North Carolina. Include on each boring the SPT blow counts and N-values at each depth, depth of the boring, hammer efficiency, depth of water table and a general description of the soil types encountered using the AASHTO Classification System.

Borings that cannot be easily correlated to their specific pole location will be returned to the Contractor for clarification; or if approved by the Engineer, the foundation may be designed using the worst-case soil condition obtained as part of this project.

3. Standard Foundation Determination:

Use the following method for determining the Design N-value:

$$N_{AVG} = \frac{N_{@1'} + N_{@2.5'} + \dots + N_{@Deepest\ Boring\ Depth}}{Total\ Number\ of\ N\ values}$$

$$Y = (N_{@1'})^2 + (N_{@2.5'})^2 + \dots + (N_{@Deepest\ Boring\ Depth})^2$$

$$Z = N_{@1'} + N_{@2.5'} + \dots + N_{@Deepest\ Boring\ Depth}$$

$$N_{STD\ DEV} = \sqrt{\left(\frac{(Total\ Number\ of\ N\ values \times Y) - Z^2}{(Total\ Number\ of\ N\ values) \times (Total\ Number\ of\ N\ values - 1)} \right)}$$

Design N-value equals lesser of the following two conditions:

$$N_{AVG} - (N_{STD\ DEV} \times 0.45)$$

OR

$$\text{Average of First Four (4) } N \text{ values} = \frac{N_{@1'} + N_{@2.5'} + N_{@5'} + N_{@7.5'}}{4}$$

Note: If less than four (4) N-values are obtained because of criteria listed in Section 2 above, use average of N-values collected for second condition. Do not include the N-value at the deepest boring depth for above calculations if the boring is discontinued at or before the required boring depth because of criteria listed in Section 2 above. Use N-value of zero (0) for weight of hammer or weight of rod. If N-value is greater than fifty (50), reduce N-value to fifty (50) for calculations.

If standard NCDOT strain poles are shown on the plans and the Contractor chooses to use standard foundations, determine a drilled pier length, “L,” for each signal pole from the Standard Strain Pole Foundations Chart (sheet M8) based on the Design N-value and the predominant soil type. For each standard pole location, submit a completed “Metal Pole Standard Foundation Selection Form” signed by the Contractor’s representative. Signature on form is for verification purposes only. Include the Design N-value calculation and resulting drilled pier length, “L,” on each form.

If non-standard site-specific poles are shown on the plans, submit completed boring logs collected in accordance with Section 2 (Soil Test) along with pole loading diagrams from the plans to the Contractor-selected pole Fabricator to assist in the pole and foundation design.

If one of the following occurs, the Standard Foundations Chart shown on the plans may not be used and a non-standard foundation may be required. In such case, contact the Engineer.

- The Design N-value is less than four (4).
- The drilled pier length, “L”, determined from the Standard Foundations Chart, is greater than the depth of the corresponding boring.

In the case where a standard foundation cannot be used, the Department will be responsible for the additional cost of the non-standard foundation.

Foundation designs are based on level ground around the traffic signal pole. If the slope around the edge of the drilled pier is steeper than 8:1 (H:V) or the proposed foundation will be less than 10 feet from the top of an embankment slope, the Contractor is responsible for providing slope information to the foundation Designer and to the Engineer so it can be considered in the design.

The “Metal Pole Standard Foundation Selection Form” may be found at:

<https://connect.ncdot.gov/resources/safety/Pages/ITS-Design-Resources.aspx>

If assistance is needed, contact the Engineer.

4. Non-Standard Foundation Design:

Design non-standard foundations based upon site-specific soil test information collected in accordance with Section 2 (Soil Test). Design drilled piers for side resistance in accordance with Section 10.8 of the *2014 AASHTO LRFD Bridge Design Specifications, 7th Edition*. Use computer software LPILE version-6.0 or later manufactured by Ensoft, Inc. to analyze drilled piers. Use computer software gINT V8i or later manufactured by Bentley Systems, Inc. with the current NCDOT gINT library and data template to produce SPT boring logs. Provide a drilled pier foundation for each pole with a length and diameter resulting in horizontal lateral movement less than 1 inch at top of the pier, and horizontal rotational movement less than 1 inch at the edge of pier. Contact the Engineer for pole loading diagrams of standard poles used for non-standard foundation designs. Submit non-standard

foundation designs including drawings, calculations, and soil boring logs to the Engineer for review and approval before construction.

C. Drilled Pier Construction:

Construct drilled pier foundation and Install anchor rod assemblies in accordance with the *Foundations and Anchor Rod Assemblies for Metal Poles* Standard Special Provision SP09-R005 located at:

<https://connect.ncdot.gov/resources/Specifications/Pages/2024-Specifications-and-Special-Provisions.aspx>

4.3. METAL POLE REMOVALS

A. Description:

Remove and dispose of existing metal support poles, and remove and dispose of existing foundations, associated anchor bolts, electrical wires and connections.

B. Construction Methods:

1. Foundations:

Remove and promptly dispose of the metal support pole foundations including reinforcing steel, electrical wires, and anchor bolts to a minimum depth of 2 feet below the finished ground elevation. At the Contractor's option, remove the complete foundation.

2. Metal Poles:

Consult Division Traffic Services regarding ownership of poles. If the Division chooses to maintain these structures in their inventory for future use, permanently mark the pole with the signal inventory number, asset inventory number or some identifying information that identifies where the pole came from

Remove the metal support poles, and promptly transport the metal support poles from the project. Use methods to remove the metal support poles and attached equipment that will not result in damage to other portions of the project or facility. Repair damages that are a result of the Contractor's actions at no additional cost to the Department.

Transport and properly dispose of the materials.

Backfill and compact disturbed areas to match the finished ground elevation. Seed unpaved areas.

Use methods to remove the foundations that will not result in damage to other portions of the project or facility. Repair damages that are a result of the Contractor's actions at no cost to the Department.

4.4. POLE NUMBERING SYSTEM

Attach an identification tag to each pole shaft section as shown on Metal Pole Standard Sheet M2 "Typical Fabrication Details for All Metal Poles."

4.5. MEASUREMENT AND PAYMENT

Actual number of metal poles with single mast arms furnished, installed, and accepted.

Actual number of metal poles with dual mast arms furnished, installed, and accepted.

Actual number of designs for mast arms with metal poles furnished and accepted.

Actual number of metal signal pole foundations removed and disposed.

Actual number of metal signal poles removed and disposed.

Actual number of soil tests with SPT borings drilled furnished and accepted.

Actual volume of concrete poured in cubic yards of drilled pier foundation furnished, installed and accepted.

No measurement will be made for foundation designs prepared with metal pole designs, as these will be considered incidental to designing Traffic Signal , CCTV or MVD support structures.

Payment will be made under:

| | |
|--------------------------------------|------------|
| Metal Pole with Single Mast Arm..... | Each |
| Metal Pole with Dual Mast Arm | Each |
| Mast Arm with Metal Pole Design..... | Each |
| Metal Pole Foundation Removal..... | Each |
| Metal Pole Removal | Each |
| Soil Test..... | Each |
| Drilled Pier Foundation..... | Cubic Yard |

5. PROTECTIVE COATING FOR METAL POLES

5.1. General

This special provision is intended for use as an additional treatment to metal traffic signal structures installed in areas where maintaining an aesthetic appearance is important and specified in the project documents. The provision contains all of the requirements necessary to accomplish this additional treatment to galvanized steel traffic signal structures fabricated by a steel manufacturer using their local powder coating/paint facility and includes the material and shop certification requirements. The provision also contains pay items for protective coating treatment to aluminum signal and pedestrian pedestals that are Standard Specification items (See Section 1743 and associated Standard Drawings). These aluminum pedestals are on the Qualified Product List (QPL), and as such would not likely be powder coated at the same facility and thus not bound by the material certification requirements in this provision. In this case, the pedestal supplier should comply with Type 6 – Supplier’s Certification as defined in Section 106-3 of the Standard Specification.

5.2. Description

Protective coating for metal poles is a supplemental durable color coating that is applied to galvanized steel and aluminum traffic signal structures. Powder Coating is the preferred supplemental protective coating process for coating galvanized steel and aluminum structures. However, for the purposes of this special provision, an Acrylic Primer and topcoat paint system is included as an acceptable alternative when protective color coating is required.

Use **RAL# 9017 Traffic Black** as the shade of protective black coating over galvanization for all steel poles including all necessary hardware in accordance with the plans and specifications.

NOTE: The selected shade of color (RAL# 9017 Traffic Black**) for black protective coating must be verified and approved by the Engineer and City of Lexington prior to fabrication. Shop drawings for metal poles requiring powder coating will not be reviewed until the approving parties listed above have approved the color.**

5.3. Materials

With the exception of aluminum components, furnish all metal poles with galvanic protection along with a tough and durable application of protective coating. Aluminum components shall have a durable powder coating application. Galvanization is not required for aluminum components.

Furnish pole caps that have a low gloss powder finish applied over a hot-dipped galvanized surface. Comply with the applicable provisions of Section 442-10 and 442-13 of the 2024 Standard Specifications.

Ensure the selected color for protective coating has been verified and approved by the Engineer and City of Lexington prior to fabrication.

5.4. Facility Approval

The Department maintains an approved producer/supplier listing for various facility types associated with this work, which include powder applicator (PA), structural steel galvanizer (SSG), and structural steel shop coating facilities (SCF). A complete list of approved facilities can be found at the following weblink: <https://apps.ncdot.gov/vendor/ApprovedProducts/Producer.aspx> Approve the coating shop facility prior to the application of any coating process. Submit all new facility requests, procedures, and documents electronically to:

Materials and Test
1801 Blue Ridge Road
Raleigh, NC 27607
Attn: Manufactured Products Engineer

Powder Coating Shop Approval

- A) Submit a quality control procedure that the company has established to ensure a quality and durable coating. The quality control procedure shall contain at a minimum the following:
- Qualified / Certified personnel to manage the QC Program and to conduct Quality Control tests
 - Qualified / certified coaters
 - Source and type of powder
 - How the powder will be stored
 - Powder application facility (heated or unheated)
 - Surface pre-treatment
 - Surface preparation including profile
 - Application methods
 - Curing conditions (conventional or infrared)
 - Curing Temperature
 - Adhesion & Holiday Detection
 - Repair Procedure
 - Storage and protection of coated items
 - Shipping and handling (packing, protection, and wrapping)
- B) Submit a powder certification from the manufacturer
- C) Submit the following to the Chemical Testing Engineer a minimum of four weeks prior to coating application.

1. Two test panels of ASTM A36 steel, $\frac{1}{4}$ or greater in thickness measuring 8 inches by 11 inches using the proposed color of the final coat; a powder coated over galvanized test panel and a powder coated over un-galvanized test panel.
2. In addition, provide two (2) samples of the same or comparable material and thickness as production pieces. Ensure production piece replicas do not exceed twelve inches (12") in length and width nor 50 pounds in weight.
3. Submit all test panels with inspection reports and records according to *Standard Specifications*, Section 442, Section 1072, Section 1076, and Section 1080.
4. Acceptance of the panels is determined by meeting the requirements of ASTM D-4541 of 800 psi for both galvanized and un-galvanized and production piece test panels.
5. Send all panels to:
Materials and Tests Unit
1801 Blue Ridge Road
Raleigh, NC 27607
Attn: Chemical Lab

5.5. POWDER COATING

A. Galvanizing

Galvanize steel products in accordance with Section 1076 of the Standard Specifications. Ensure the fabricator or designated representative(s) that is supplying the components to be galvanized communicates with the galvanizer to indicate that the galvanized pieces will be powder coated to avoid water or chromate quenching.

B. Surface Preparation

Comply with manufacturer's recommended surface coating specifications, Steel Structure Painting Council (SSPC) specifications and applicable articles of Section 442 (Painting Steel Structures) of the Standard Specifications. Ensure that surface preparations and treatments are performed and meet the requirements of the above referenced specifications.

Some pole components, specifically steel plates $\frac{3}{4}$ inches or more in thickness, may need blast cleaning prior to structure assembly to remove impurities and non-metallic foreign materials. Mechanically remove all weld flux after structure is assembled

Degrease and prepare steel structure for zinc coating after assembly using full immersion baths and pickling processes in heat controlled caustic and acid solutions. Rinse and clean structure to remove caustic or acid solutions by immersion in a circulating fresh water bath. Immerse structure in a heat controlled concentrated zinc ammonium chloride flux solution and air dry as a final prep before hot-dip galvanization.

Ensure that the surface preparation is no less than specified by the powder manufacturer's recommendations. Prepare all components to be coated in accordance with SSPC SP-2 (Hand Tool Cleaning) and/or SSPC SP-3 (Power Tool Cleaning). Remove all drainage spikes, high spots, protrusions or other surface defects using hand or power tools. Do not remove the galvanization below the limits set forth in AASHTO M111.

Remove grease, oils, moisture, scale, rust or any other foreign matter prior to powder coating to ensure ideal adhesion and coating performance. Prepare and coat the galvanized surface as soon as possible after the galvanization process.

C. Powder Coating Application and Curing

Prepare galvanized finish for powder coating by brush blasting in accordance with SSPC-SP7. Ensure all threaded components of the structure are protected from damage during blasting process.

Use thermosetting powder resin that meets 5A or 5B classifications of ASTM D3359. Apply powder coating electrostatically. Follow manufacturer's recommended preheating requirements. Ensure the topcoat finish is applied uniformly to all surfaces with a dry film thickness of between 3.0 to 5.0 mils. Cure the topcoat by heating the structure to manufacturer recommended temperatures at the duration required to ensure complete and uniform bond.

D. Quality Control

Ensure the applicator provides all test reports and documentation and inspects all coated material as outlined in the Standard Specifications, Section 442, Section 1072, Section 1076, and Section 1080. Ensure the quality control inspection is kept separate from the production functions.

E. Storage, Shipping, and Handling

Store all powder coated material inside or as directed by the Engineer.

Protect the product from incurring damage during all shipping, handling, and storing activities. Do not store the product directly on the ground or in areas where water may pool; the Engineer determines the effectiveness of all storage, shipping and handling methods.

F. Repair of Powder Coated Material

Repair all damage to the coating by the original method of application as outlined in the coating facility's repair procedure. Ensure all repair areas meet the original requirements for adhesion as stated in this Project Special Provision.

Photograph, document, and report all damages upon delivery to the project site prior to unloading. Provide documented damage notifications to the Engineer or to their authorized representative so the application firm can be notified. The Engineer has the authority to accept or reject the material as outlined in the Standard Specifications.

Submit to the Engineer a repair procedure for damaged coatings which occur during storage, transporting, handling and or installation. Utilize a liquid paint approved by the Department, compatible with the powder applied product. Ensure all repair areas demonstrate an adhesion rating of 400 psi in accordance with ASTM D-4541. Obtain Engineer's acceptance of the final finish.

5.6. ACRYLIC PRIMER AND TOPCOAT PAINT SYSTEM

A. Description

Follow NCDOT procedures for Powder Coating over Galvanizing. Provide an Acrylic Primer and topcoat when a substitute for powder coating is necessary.

Provide supplemental coating for all mast arms with metal signal poles and all necessary hardware for the signalized intersection in accordance with the Structural Steel Shop Coatings Program, NCDOT Standard specifications – sections 442 and 1080, as contained herein, and as shown on the plans. The Structural Steel Shop Coatings Program can be found at the following link:

<https://connect.ncdot.gov/resources/Materials/MaterialsResources/Structural%20Steel%20Shop%20Coatings%20Program.pdf>

Ensure all painting work for new structures, except field touch-up and bolt painting is performed in the shop.

Coatings Shop Approval

Use only NCDOT approved shop coating facilities meeting the requirements outlined in the current edition of the Structural Steel Shop Coatings Program. This program is available on the Materials and Tests website. [Structural Steel Shop Coatings Program.pdf \(ncdot.gov\)](http://www.ncdot.gov/Structural%20Steel%20Shop%20Coatings%20Program.pdf)

Provide shop certification in accordance with the Structural Steel Shop Coatings Program (Shop facilities that are currently certified and in good standing with the American Institute Steel Construction (AISC) / Sophisticated Paint Endorsement (SPE) and/or the Society of Protective Coatings (SSPC) Qualification Procedure Three (QP-3).

B. Surface Preparation

Ensure all surface preparation is not less than that specified by the paint manufacturer's recommendations.

Clean galvanized surfaces to be painted with a 2,500-psi pressure washer. Allow surfaces to dry completely before beginning surface preparation.

Ensure all components to be coated are prepared in accordance with SSPC SP2 (Hand Tool Cleaning and or SSPC SP-3 (Power Tool Cleaning). Smooth high spots and rough edges, such as metal drip lines, of galvanized surfaces in accordance with ASTM D6386. Do not remove the galvanization below the limits set forth in AASHTO M111.

Perform abrasive sweep blasting in accordance with ASTM D6386. Refer to this section for a description of the abrasive blast material to be used. Use a material and technique capable of stripping action to remove corrosion products and to provide a rough surface profile while leaving base zinc layers intact.

Blow down all blasted surfaces with clean compressed air to provide a clean, dry surface.

Ensure all surfaces are free of visible zinc oxides or zinc hydroxides.

C. Materials

Use an approved/qualified waterborne paint meeting the requirements of NCDOT Standard specification section 1080. Do not apply paint until each batch has been tested by the Department. Provide color as specified in the contract documents.

Ensure all paint used on this contract is produced by the same manufacturer.

D. Painting

Apply paint in accordance with the requirements of the Structural Steel Shop Coatings Program, Section 442 and Section 1080 of the *Standard Specifications* as modified herein.

System for Paint over Galvanize Acrylic Primer and Topcoats

| Coat | Material | Mils Dry/Wet Film Thickness | Mils Dry/Wet Film Thickness |
|---------|--------------|-----------------------------|-----------------------------|
| | | Minimum | Maximum |
| Primer | 1080-9 White | 3.0 DFT | 5.0 DFT |
| Stripe | 1080-9 * | 4.0 WFT | 7.0 WFT |
| Topcoat | 1080-9 * | 2.0 DFT | 4.0 DFT |

| | | | |
|-------|--|---------|---------|
| Total | | 5.0 DFT | 9.0 DFT |
|-------|--|---------|---------|

***Ensure the selected color for protective coating has been verified and approved by the Engineer and City of Lexington prior to fabrication.**

The time between blast and coating application shall be in accordance with ASTM D6386 time requirements. In no case shall the prepared surface extend beyond 8 hours.

Mask off and do not paint all data plates and faying surfaces prior to application.

Spray apply all coatings except for the stripe coat. Brush apply the stripe coat to all plate edges, welds, bolt holes and bolts prior to applying the finish coat.

E. Curing

Follow manufacturer recommendations.

F. Inspection

Quality Control shall conduct the required quality control tests as outlined in the Structural Steel Shop Coatings Program and report the minimum information required by the appropriate ASTM test methods. At a minimum, quality control forms shall be on company letterhead with logo that provides a daily inspection report form equivalent to the information required on the M&T-611 Form. The M&T-611 Form can be found in the Structural Steel Shop Coatings Program. Dry Film Thickness (DFT) measurements shall be obtained on all coating layers, including the galvanized layer and shall incorporate the use of a Type 2 gauge as defined in SSPC PA-2.

Ensure all material is of a uniform appearance free of runs, drips, and sags.

G. Handling

Do not handle, ship, or erect coated members until paint is thoroughly dry.

Protect all shipping and handling either from the coating facility to project site and or storage site to area(s) to construction location from incurring damage to product. Wood blocks and nylon slings are recommended for securing, loading, hoisting or storing members.

H. Repair of Damaged Coating

Repair damage occurring to the galvanized portion of the coating during shipment or installation in accordance with Articles 1076-7 and 1080-7 of the *Standard Specifications*. Repair damage occurring to the painted portion of the coating during shipment or installation by applying 4.0-7.0 wet mils of topcoat with a brush or roller and feather or taper this to be level with the surrounding areas.

5.7. MEASUREMENT AND PAYMENT

Actual number of single mast arm poles with protective coating applied furnished, installed, and accepted.

Actual number of dual mast arm poles with protective coating applied furnished, installed, and accepted.

Actual number of signal TYPE I pedestals with protective coating applied furnished, installed, and accepted.

Actual number of signal TYPE II pedestals with protective coating applied furnished, installed, and accepted.

Actual number of signal TYPE III pedestals with protective coating applied furnished, installed, and accepted.

Payment will be made under:

| | | |
|---|-------|------|
| Protective Coating for Single Mast Arm Pole (_____) | | Each |
| Protective Coating for Dual Mast Arm Pole (_____) | | Each |
| Protective Coating for TYPE I Pushbutton Post (_____) | | Each |
| Protective Coating for TYPE II Signal Pedestal (_____) | | Each |
| Protective Coating for TYPE III Signal Pedestal (_____) | | Each |

6. ETHERNET EDGE SWITCH

Furnish and install a managed Ethernet edge switch as specified below that is fully compatible, interoperable, and completely interchangeable and functional within the existing City, Division, or Statewide traffic signal system communications network.

6.1. DESCRIPTION

A. Ethernet Edge Switch:

Furnish and install a hardened, field Ethernet edge switch (hereafter “edge switch”) for the traffic signal controller or ITS device as specified below. Ensure that the edge switch provides wire-speed, fast Ethernet connectivity at transmission rates of 1000 megabits per second from each remote traffic signal controller or ITS device location to the routing switches.

Contact the City or NCDIT to arrange for the programming of the new Field Ethernet Switches with the necessary network configuration data, including but not limited to, the IP Address, Default Gateway, Subnet Mask and VLAN ID information. Provide a minimum ten (10) working days’ notice to allow the City or NCDIT to program the new devices.

B. Network Management:

Ensure that the edge switch is fully compatible with the existing City, Division, or Statewide Network Management Software.

6.2. MATERIALS

A. General:

Ensure that the edge switch is fully compatible and interoperable with the trunk Ethernet network interface and that the edge switch supports half and full duplex Ethernet communications.

Furnish an edge switch that provide 99.999% error-free operation, and that complies with the Electronic Industries Alliance (EIA) Ethernet data communication requirements using single-mode fiber-optic transmission medium and copper transmission medium. Ensure that the edge switch has a minimum mean time between failures (MTBF) of 10 years, or 87,600 hours, as calculated using the Bellcore/Telcordia SR-332 standard for reliability prediction.

B. Compatibility Acceptance

The Engineer has the authority to require the Contractor to submit a sample Field Ethernet Switch and SFP along with all supporting documentation, software and testing procedures to allow a compatibility acceptance test be performed prior to approving the proposed Field Ethernet Switch and Field Ethernet Transceiver for deployment. The Compatibility Acceptance testing will ensure that

the proposed device is 100% compatible and interoperable with the existing City, Division, or Statewide Signal System network, monitoring software and Traffic Operations Center network hardware. Allow fifteen (15) working days for the Compatibility Acceptance Testing to be performed

C. Standards:

Ensure that the edge switch complies with all applicable IEEE networking standards for Ethernet communications, including but not limited to:

- IEEE 802.1D standard for media access control (MAC) bridges used with the Spanning Tree Protocol (STP);
- IEEE 802.1Q standard for port-based virtual local area networks (VLANs);
- IEEE 802.1P standard for Quality of Service (QoS);
- IEEE 802.1w standard for MAC bridges used with the Rapid Spanning Tree Protocol (RSTP);
- IEEE 802.1s standard for MAC bridges used with the Multiple Spanning Tree Protocol;
- IEEE 802.1x standard for port based network access control, including RADIUS;
- IEEE 802.3 standard for local area network (LAN) and metropolitan area network (MAN) access and physical layer specifications;
- IEEE 802.3u supplement standard regarding 100 Base TX/100 Base FX;
- IEEE 802.3x standard regarding flow control with full duplex operation; and
- IFC 2236 regarding IGMP v2 compliance.
- IEEE 802.1AB Link Layer Discovery Protocol (LLDP)
- IEEE 802.3ad Ethernet Link Aggregation
- IEEE 802.3i for 10BASE-T (10 Mbit/s over Fiber-Optic)
- IEEE 802.3ab for 1000BASE-T (1Gbit/s over Ethernet)
- IEEE 802.3z for 1000BASE-X (1 Gbit/s Ethernet over Fiber-Optic)

D. Functional:

Ensure that the edge switch supports all Layer 2 management features and certain Layer 3 features related to multicast data transmission and routing. These features shall include, but not be limited to:

- An STP healing/convergence rate that meets or exceeds specifications published in the IEEE 802.1D standard.
- An RSTP healing/convergence rate that meets or exceeds specifications published in the IEEE 802.1w standard.
- An Ethernet edge switch that is a port-based VLAN and supports VLAN tagging that meets or exceeds specifications as published in the IEEE 802.1Q standard, and has a minimum 4-kilobit VLAN address table (254 simultaneous).
- A forwarding/filtering rate that is a minimum of 14,880 packets per second for 10 megabits per second and 148,800 packets per second for 100 megabits per second.
- A minimum 4-kilobit MAC address table.
- Support of Traffic Class Expediting and Dynamic Multicast Filtering.
- Support of, at a minimum, snooping of Version 2 & 3 of the Internet Group Management Protocol (IGMP).
- Support of remote and local setup and management via telnet or secure Web-based GUI and command line interfaces.

- Support of the Simple Network Management Protocol version 3 (SNMPv3). Verify that the Ethernet edge switch can be accessed using the resident EIA-232 management port, a telecommunication network, or the Trivial File Transfer Protocol (TFTP).
- Port security through controlling access by the users. Ensure that the Ethernet edge switch has the capability to generate an alarm and shut down ports when an unauthorized user accesses the network.
- Support of remote monitoring (RMON-1 & RMON-2) of the Ethernet agent.
- Support of the TFTP and SNTP. Ensure that the Ethernet edge switch supports port mirroring for troubleshooting purposes when combined with a network analyzer.

E. Physical Features:

Ports: Provide 10/100/1000 Mbps auto-negotiating ports (RJ-45) copper Fast Ethernet ports for all edge switches. Provide auto-negotiation circuitry that will automatically negotiate the highest possible data rate and duplex operation possible with attached devices supporting the IEEE 802.3 Clause 28 auto-negotiation standard.

Optical Ports: Ensure that all fiber-optic link ports operate at 1310 or 1550 nanometers in single mode. Provide Type LC connectors for the optical ports, as specified in the Plans or by the Engineer. Do not use mechanical transfer registered jack (MTRJ) type connectors.

Provide an edge switch having a minimum of two optical 100/1000 Base X ports capable of transmitting data at 100/1000 megabits per second. Ensure that each optical port consists of a pair of fibers; one fiber will transmit (TX) data and one fiber will receive (RX) data. Ensure that the optical ports have an optical power budget of at least 15 dB. Provide small form-factor pluggable modules (SFPs) with a maximum range that meets or exceeds the distance requirement as indicated on the Plans.

Copper Ports: Provide an edge switch that includes a minimum of four copper ports. Provide Type RJ-45 copper ports and that auto-negotiate speed (i.e., 10/100/1000 Base) and duplex (i.e., full or half). Ensure that all 10/100/1000 Base TX ports meet the specifications detailed in this section and are compliant with the IEEE 802.3 standard pinouts. Ensure that all Category 6 unshielded twisted pair/shielded twisted pair network cables are compliant with the EIA/TIA-568-B standard.

Port Security: Ensure that the edge switch supports/complies with the following (remotely) minimum requirements:

- Ability to configure static MAC addresses access;
- Ability to disable automatic address learning per ports; know hereafter as Secure Port. Secure Ports only forward; and
- Trap and alarm upon any unauthorized MAC address and shutdown for programmable duration. Port shutdown requires administrator to manually reset the port before communications are allowed.

F. Management Capabilities:

Ensure that the edge switch supports all Layer 2 management features and certain Layer 3 features related to multicast data transmission and routing. These features shall include, but not be limited to:

- An STP healing/convergence rate that meets or exceeds specifications published in the IEEE 802.1 D standards;
- An RSTP healing/convergence rate that meets or exceeds specifications published in the IEEE 802.1w standard;

- An Ethernet edge switch that is a port-based VLAN and supports VLAN tagging that meets or exceeds specifications as published in the IEEE 802.1Q standard, and has a minimum 4-kilobit VLAN address table (254 simultaneous);
- A forwarding/filtering rate that is a minimum of 14,880 packets per second for 10 megabits per second, 148,800 packets per second for 100 megabits per second and 1,488,000 packets per second for 1000 megabits per second;
- A minimum 4-kilobit MAC address table;
- Support of Traffic Class Expediting and Dynamic Multicast Filtering.
- Support of, at a minimum, snooping of Version 2 & 3 of the Internet Group Management Protocol (IGMP);
- Support of remote and local setup and management via telnet or secure Web-based GUI and command line interfaces; and
- Support of the Simple Network Management Protocol (SNMP). Verify that the Ethernet edge switch can be accessed using the resident EIA-232 management port, a telecommunication network, or the Trivial File Transfer Protocol (TFTP).

Network Capabilities: Provide an edge switch that supports/complies with the following minimum requirements:

- Provide full implementation of IGMPv2 snooping (RFC 2236);
- Provide full implementation of SNMPv1, SNMPv2c, and/or SNMPv3;
- Provide support for the following RMON-I groups, at a minimum:
 - Part 1: Statistics
 - Part 2: History
 - Part 3: Alarm
 - Part 9: Event
- Provide support for the following RMON-2 groups, at a minimum:
 - Part 13: Address Map
 - Part 16: Layer Host
 - Part 17: Layer Matrix
 - Part 18: User History
- Capable of mirroring any port to any other port within the switch;
- Meet the IEEE 802.1Q (VLAN) standard per port for up to four VLANs;
- Meet the IEEE 802.3ad (Port Trunking) standard for a minimum of two groups of four ports;
- Password manageable;
- Telnet/CLI;
- HTTP (Embedded Web Server) with Secure Sockets Layer (SSL); and
- Full implementation of RFC 783 (TFTP) to allow remote firmware upgrades.

Network Security: Provide an edge switch that supports/complies with the following (remotely) minimum network security requirements:

- Multi-level user passwords;
- RADIUS centralized password management (IEEE 802.1X);
- SNMPv3 encrypted authentication and access security;
- Port security through controlling access by the users: ensure that the Ethernet edge switch has the capability to generate an alarm and shut down ports when an unauthorized user accesses the network;
- Support of remote monitoring (RMON-1&2) of the Ethernet agent; and
- Support of the TFTP and SNTP. Ensure that the Ethernet edge switch supports port mirroring for troubleshooting purposes when combined with a network analyzer.

G. Electrical Specifications:

Ensure that the edge switch operates and power is supplied with 115 volts of alternating current (VAC). Ensure that the edge switch has a minimum operating input of 110 VAC and a maximum operating input of 130 VAC. Ensure that if the device requires operating voltages other than 120 VAC, supply the required voltage converter. Ensure that the maximum power consumption does not exceed 50 watts. Ensure that the edge switch has diagnostic light emitting diodes (LEDs), including link, TX, RX, speed (for Category 6 ports only), and power LEDs.

H. Environmental Specifications:

Ensure that the edge switch performs all of the required functions during and after being subjected to an ambient operating temperature range of -30 degrees to 165 degrees Fahrenheit as defined in the environmental requirements section of the NEMA TS 2 standard, with a noncondensing humidity of 0 to 95%.

Provide certification that the device has successfully completed environmental testing as defined in the environmental requirements section of the NEMA TS 2 standard. Provide certification that the device meets the vibration and shock resistance requirements of Sections 2.1.9 and 2.1.10, respectively, of the NEMA TS 2 standard. Ensure that the edge switch is protected from rain, dust, corrosive elements, and typical conditions found in a roadside environment.

The edge switch shall meet or exceed the following environmental standards:

- IEEE 1613 (electric utility substations)
- IEC 61850-3 (electric utility substations)
- IEEE 61800-3 (variable speed drive systems)
- IEC 61000-6-2 (generic industrial)
- EMF – FCC Part 15 CISPR (EN5502) Class A

I. Ethernet Patch Cable:

Furnish a factory pre-terminated/pre-connectorized Ethernet patch cable with each edge switch. Furnish Ethernet patch cables meeting the following physical requirements:

- Five (5)-foot length
- Category 6 or better
- Factory-installed RJ-45 connectors on both ends
- Molded anti-snag hoods over connectors
- Gold plated connectors
- Copper-clad aluminum is **NOT** allowed.

Furnish Fast Ethernet patch cords meeting the following minimum performance requirements:

- TIA/EIA-568-B-5, Additional Transmission Performance Specifications for 4-pair 100 Ω Enhanced Category 6 Cabling
- Frequency Range: 1-100 MHz
- Near-End Crosstalk (NEXT): 30.1 dB
- Power-sum NEXT: 27.1 dB
- Attenuation to Crosstalk Ratio (ACR): 6.1 dB
- Power-sum ACR: 3.1 dB
- Return Loss: 10dB

- Propagation Delay: 548 nsec

6.3. CONSTRUCTION METHODS

A. General:

Ensure that the edge switch is UL listed.

Verify that network/field/data patch cords meet all ANSI/EIA/TIA requirements for Category 6 four-pair unshielded twisted pair cabling with stranded conductors and RJ45 connectors.

Contact the City, Division, or NCDIT a minimum of 10 working days prior to installation to allow for the programming of the edge switch.

B. Edge Switch:

Mount the edge switch inside each field cabinet by securely fastening the edge switch to the upper end of the right rear vertical rail of the equipment rack using manufacturer-recommended or Engineer-approved attachment methods, attachment hardware and fasteners.

Ensure that the edge switch is mounted securely in the cabinet and is fully accessible by field technicians without blocking access to other equipment. Verify that fiber-optic jumpers consist of a length of cable that has connectors on both ends, primarily used for interconnecting termination or patching facilities and/or equipment.

6.4. MEASUREMENT AND PAYMENT

Ethernet edge switch will be measured and paid as the actual number of Ethernet edge switches furnished, installed, and accepted.

No separate measurement will be made for Ethernet patch cable, small form factor pluggable modules (SFPs), power cord, mounting hardware, nuts, bolts, brackets, edge switch programming, or relocating Ethernet edge switches as these will be considered incidental to furnishing and installing the *Ethernet Edge Switches*.

Payment will be made under:

Ethernet Edge Switch Each

7. REMOVAL OF TYPE II SIGNAL PEDESTALS

7.1. DESCRIPTION

Type II signal pedestals and foundations will be removed after the deployment of the final signal designs at the following locations:

- 09-0402 – NC 8 at 9th Street
- 09-0401 – NC 8 at 11th Street

7.2. CONSTRUCTION METHODS

(A) General

Remove the existing Type II pedestals and foundations at the locations described above in Section 7.1.

(B) Removal

Use methods to remove the Type II Pedestals and Foundations that will not result in damage to other portions of the project or facility. Repair damage that results from the Contractor's actions at no additional cost to the Department.

(C) Disposal

At the end of the project, promptly transport the removed Type II Pedestals and supporting hardware to the Division 9 Traffic Services Office located at 350 Craft Drive in Winston-Salem, NC.

Return the removed equipment and material between the hours of 8:00 a.m. and 12:00 p.m. Monday through Thursday or at a time mutually agreed upon by the Contractor and the Engineer. Replace or repair all material lost or damaged during its removal and transit. Label all returned equipment and material to indicate its original location.

7.3. MEASUREMENT AND PAYMENT

No separate measurement will be made for the removal and transporting of the Type II Pedestals as this will be considered incidental to furnishing and installing *Type II Pedestal with Foundation*.

County: DAVIDSON

| Line # | Item Number | Sec # | Description | Quantity | Unit Cost | Amount |
|----------------------|--------------|-------|--|--------------|-----------|--------|
| ROADWAY ITEMS | | | | | | |
| 0001 | 0000100000-N | 800 | MOBILIZATION | Lump Sum | L.S. | |
| 0002 | 0000400000-N | 801 | CONSTRUCTION SURVEYING | Lump Sum | L.S. | |
| 0003 | 0043000000-N | 226 | GRADING | Lump Sum | L.S. | |
| 0004 | 0050000000-E | 226 | SUPPLEMENTARY CLEARING & GRUBBING | 1 ACR | | |
| 0005 | 0057000000-E | 226 | UNDERCUT EXCAVATION | 5,000 CY | | |
| 0006 | 0134000000-E | 240 | DRAINAGE DITCH EXCAVATION | 640 CY | | |
| 0007 | 0195000000-E | 265 | SELECT GRANULAR MATERIAL | 4,810 CY | | |
| 0008 | 0196000000-E | 270 | GEOTEXTILE FOR SOIL STABILIZATION | 5,010 SY | | |
| 0009 | 0255000000-E | SP | GENERIC GRADING ITEM HAULING AND DISPOSAL OF PETROLEUM CONTAMINATED SOIL | 200 TON | | |
| 0010 | 0318000000-E | 300 | FOUNDATION CONDITIONING MATERIAL, MINOR STRUCTURES | 1,125 TON | | |
| 0011 | 0321000000-E | 300 | FOUNDATION CONDITIONING GEOTEXTILE | 4,668 SY | | |
| 0012 | 0335200000-E | 305 | 15" DRAINAGE PIPE | 252 LF | | |
| 0013 | 0335300000-E | 305 | 18" DRAINAGE PIPE | 64 LF | | |
| 0014 | 0335400000-E | 305 | 24" DRAINAGE PIPE | 128 LF | | |
| 0015 | 0335500000-E | 305 | 30" DRAINAGE PIPE | 40 LF | | |
| 0016 | 0335600000-E | 305 | 36" DRAINAGE PIPE | 164 LF | | |
| 0017 | 0366000000-E | 310 | 15" RC PIPE CULVERTS, CLASS III | 364 LF | | |

County: DAVIDSON

| Line # | Item Number | Sec # | Description | Quantity | Unit Cost | Amount |
|--------|--------------|-------|---|-------------|-----------|--------|
| 0018 | 0372000000-E | 310 | 18" RC PIPE CULVERTS, CLASS III | 608 LF | | |
| 0019 | 0378000000-E | 310 | 24" RC PIPE CULVERTS, CLASS III | 224 LF | | |
| 0020 | 0384000000-E | 310 | 30" RC PIPE CULVERTS, CLASS III | 76 LF | | |
| 0021 | 0448200000-E | 310 | 15" RC PIPE CULVERTS, CLASS IV | 3,616 LF | | |
| 0022 | 0448300000-E | 310 | 18" RC PIPE CULVERTS, CLASS IV | 1,112 LF | | |
| 0023 | 0448400000-E | 310 | 24" RC PIPE CULVERTS, CLASS IV | 204 LF | | |
| 0024 | 0449000000-E | 310 | *** RC PIPE CULVERTS, CLASS V (15") | 104 LF | | |
| 0025 | 0449000000-E | 310 | *** RC PIPE CULVERTS, CLASS V (30") | 40 LF | | |
| 0026 | 0588000000-E | 310 | 18" CS PIPE CULVERTS, 0.064" THICK | 48 LF | | |
| 0027 | 0594000000-E | 310 | 24" CS PIPE CULVERTS, 0.064" THICK | 44 LF | | |
| 0028 | 0636000000-E | 310 | *** CS PIPE ELBOWS, ***** THICK (18", 0.064") | 2 EA | | |
| 0029 | 0973100000-E | 330 | *** WELDED STEEL PIPE, ***** THICK, GRADE B IN SOIL (18", 0.250") | 68 LF | | |
| 0030 | 0973300000-E | 330 | *** WELDED STEEL PIPE, ***** THICK, GRADE B NOT IN SOIL (18", 0.250") | 68 LF | | |
| 0031 | 0995000000-E | 340 | PIPE REMOVAL | 3,444 LF | | |
| 0032 | 1099500000-E | 505 | SHALLOW UNDERCUT | 350 CY | | |
| 0033 | 1099700000-E | 505 | CLASS IV SUBGRADE STABILIZATION | 800 TON | | |
| 0034 | 1112000000-E | 505 | GEOTEXTILE FOR SUBGRADE STABILIZATION | 1,200 SY | | |

County: DAVIDSON

| Line # | Item Number | Sec # | Description | Quantity | Unit Cost | Amount |
|--------|--------------|-------|--|--------------|-----------|--------|
| 0035 | 1121000000-E | 520 | AGGREGATE BASE COURSE | 140 TON | | |
| 0036 | 1220000000-E | 545 | INCIDENTAL STONE BASE | 500 TON | | |
| 0037 | 1297000000-E | 607 | MILLING ASPHALT PAVEMENT, **** DEPTH (1-1/2") | 15,000 SY | | |
| 0038 | 1308000000-E | 607 | MILLING ASPHALT PAVEMENT, **** TO ***** (0" TO 3") | 7,500 SY | | |
| 0039 | 1330000000-E | 607 | INCIDENTAL MILLING | 7,500 SY | | |
| 0040 | 1491000000-E | 610 | ASPHALT CONC BASE COURSE, TYPE B25.0C | 7,300 TON | | |
| 0041 | 1503000000-E | 610 | ASPHALT CONC INTERMEDIATE COURSE, TYPE I19.0C | 6,600 TON | | |
| 0042 | 1523000000-E | 610 | ASPHALT CONC SURFACE COURSE, TYPE S9.5C | 7,700 TON | | |
| 0043 | 1575000000-E | 620 | ASPHALT BINDER FOR PLANT MIX | 1,100 TON | | |
| 0044 | 1693000000-E | 654 | ASPHALT PLANT MIX, PAVEMENT REPAIR | 700 TON | | |
| 0045 | 2000000000-N | 806 | RIGHT-OF-WAY MARKERS | 75 EA | | |
| 0046 | 2022000000-E | 815 | SUBDRAIN EXCAVATION | 45 CY | | |
| 0047 | 2026000000-E | 815 | GEOTEXTILE FOR SUBSURFACE DRAINS | 200 SY | | |
| 0048 | 2036000000-E | 815 | SUBDRAIN COARSE AGGREGATE | 34 CY | | |
| 0049 | 2044000000-E | 815 | 6" PERFORATED SUBDRAIN PIPE | 200 LF | | |
| 0050 | 2070000000-N | 815 | SUBDRAIN PIPE OUTLET | 1 EA | | |
| 0051 | 2077000000-E | 815 | 6" OUTLET PIPE | 6 LF | | |

County: DAVIDSON

| Line # | Item Number | Sec # | Description | Quantity | Unit Cost | Amount |
|--------|--------------|-------|--|-------------|-----------|--------|
| 0052 | 2253000000-E | 840 | PIPE COLLARS | 0.5 CY | | |
| 0053 | 2286000000-N | 840 | MASONRY DRAINAGE STRUCTURES | 99 EA | | |
| 0054 | 2308000000-E | 840 | MASONRY DRAINAGE STRUCTURES | 62 LF | | |
| 0055 | 2364000000-N | 840 | FRAME WITH TWO GRATES, STD 840.16 | 9 EA | | |
| 0056 | 2366000000-N | 840 | FRAME WITH TWO GRATES, STD 840.24 | 4 EA | | |
| 0057 | 2367000000-N | 840 | FRAME WITH TWO GRATES, STD 840.29 | 8 EA | | |
| 0058 | 2374000000-N | 840 | FRAME WITH GRATE & HOOD, STD 840.03, TYPE ** (E) | 12 EA | | |
| 0059 | 2374000000-N | 840 | FRAME WITH GRATE & HOOD, STD 840.03, TYPE ** (F) | 32 EA | | |
| 0060 | 2374000000-N | 840 | FRAME WITH GRATE & HOOD, STD 840.03, TYPE ** (G) | 29 EA | | |
| 0061 | 2396000000-N | 840 | FRAME WITH COVER, STD 840.54 | 5 EA | | |
| 0062 | 2440000000-N | 852 | CONCRETE TRANSITIONAL SECTION FOR CATCH BASIN | 1 EA | | |
| 0063 | 2535000000-E | 846 | *** X *** CONCRETE CURB (8" X 18") | 900 LF | | |
| 0064 | 2542000000-E | 846 | 1'-6" CONCRETE CURB & GUTTER | 2,250 LF | | |
| 0065 | 2549000000-E | 846 | 2'-6" CONCRETE CURB & GUTTER | 8,100 LF | | |
| 0066 | 2570000000-N | SP | MODIFIED CONCRETE FLUME | 2 EA | | |
| 0067 | 2580000000-E | 846 | CONCRETE VALLEY GUTTER | 1,000 LF | | |
| 0068 | 2591000000-E | 848 | 4" CONCRETE SIDEWALK | 2,950 SY | | |

County: DAVIDSON

| Line # | Item Number | Sec # | Description | Quantity | Unit Cost | Amount |
|--------|--------------|-------|--|-------------|-----------|--------|
| 0069 | 2605000000-N | 848 | CONCRETE CURB RAMPS | 32 EA | | |
| 0070 | 2612000000-E | 848 | 6" CONCRETE DRIVEWAY | 500 SY | | |
| 0071 | 2619000000-E | 850 | 4" CONCRETE PAVED DITCH | 11 SY | | |
| 0072 | 2655000000-E | 852 | 5" MONOLITHIC CONCRETE ISLANDS (KEYED IN) | 1,100 SY | | |
| 0073 | 2800000000-N | 858 | ADJUSTMENT OF CATCH BASINS | 1 EA | | |
| 0074 | 3536000000-E | 866 | CHAIN LINK FENCE, 48" FABRIC | 220 LF | | |
| 0075 | 3542000000-E | 866 | METAL LINE POSTS FOR 48" CHAIN LINK FENCE | 19 EA | | |
| 0076 | 3548000000-E | 866 | METAL TERMINAL POSTS FOR 48" CHAIN LINK FENCE | 2 EA | | |
| 0077 | 3628000000-E | 876 | RIP RAP, CLASS I | 380 TON | | |
| 0078 | 3649000000-E | 876 | RIP RAP, CLASS B | 4 TON | | |
| 0079 | 3656000000-E | 876 | GEOTEXTILE FOR DRAINAGE | 1,129 SY | | |
| 0080 | 4072000000-E | 903 | SUPPORTS, 3-LB STEEL U-CHANNEL | 750 LF | | |
| 0081 | 4102000000-N | 904 | SIGN ERECTION, TYPE E | 27 EA | | |
| 0082 | 4108000000-N | 904 | SIGN ERECTION, TYPE F | 4 EA | | |
| 0083 | 4116100000-N | 904 | SIGN ERECTION, RELOCATE TYPE **** (GROUND MOUNTED) (E) | 1 EA | | |
| 0084 | 4155000000-N | 907 | DISPOSAL OF SIGN SYSTEM, U- CHANNEL | 37 EA | | |
| 0085 | 4400000000-E | 1110 | WORK ZONE SIGNS (STATIONARY) | 264 SF | | |

County: DAVIDSON

| Line # | Item Number | Sec # | Description | Quantity | Unit Cost | Amount |
|--------|--------------|-------|---|--------------|-----------|--------|
| 0086 | 4405000000-E | 1110 | WORK ZONE SIGNS (PORTABLE) | 242 SF | | |
| 0087 | 4410000000-E | 1110 | WORK ZONE SIGNS (BARRICADE MOUNTED) | 10 SF | | |
| 0088 | 4415000000-N | 1115 | FLASHING ARROW BOARD | 4 EA | | |
| 0089 | 4420000000-N | 1120 | PORTABLE CHANGEABLE MESSAGE SIGN | 2 EA | | |
| 0090 | 4430000000-N | 1130 | DRUMS | 300 EA | | |
| 0091 | 4435000000-N | 1135 | CONES | 100 EA | | |
| 0092 | 4445000000-E | 1145 | BARRICADES (TYPE III) | 64 LF | | |
| 0093 | 4447000000-E | SP | PEDESTRIAN CHANNELIZING DEVICES | 30 LF | | |
| 0094 | 4455000000-N | 1150 | FLAGGER | 60 DAY | | |
| 0095 | 4480000000-N | 1165 | TMA | 2 EA | | |
| 0096 | 4516000000-N | 1180 | SKINNY DRUM | 100 EA | | |
| 0097 | 4600000000-N | SP | GENERIC TRAFFIC CONTROL ITEM AUDIBLE WARNING DEVICE | 2 EA | | |
| 0098 | 4685000000-E | 1205 | THERMOPLASTIC PAVEMENT MARKING LINES (4", 90 MILS) | 18,828 LF | | |
| 0099 | 4695000000-E | 1205 | THERMOPLASTIC PAVEMENT MARKING LINES (8", 90 MILS) | 4,130 LF | | |
| 0100 | 4709000000-E | 1205 | THERMOPLASTIC PAVEMENT MARKING LINES (24", 90 MILS) | 700 LF | | |
| 0101 | 4725000000-E | 1205 | THERMOPLASTIC PAVEMENT MARKING SYMBOL (90 MILS) | 82 EA | | |
| 0102 | 4810000000-E | 1205 | PAINT PAVEMENT MARKING LINES (4") | 26,231 LF | | |

County: DAVIDSON

| Line # | Item Number | Sec # | Description | Quantity | Unit Cost | Amount |
|--------|--------------|-------|------------------------------------|--------------|-----------|--------|
| 0103 | 4820000000-E | 1205 | PAINT PAVEMENT MARKING LINES (8") | 4,276 LF | | |
| 0104 | 4835000000-E | 1205 | PAINT PAVEMENT MARKING LINES (24") | 950 LF | | |
| 0105 | 4840000000-N | 1205 | PAINT PAVEMENT MARKING CHARACTER | 8 EA | | |
| 0106 | 4845000000-N | 1205 | PAINT PAVEMENT MARKING SYMBOL | 115 EA | | |
| 0107 | 5325600000-E | 1510 | 6" WATER LINE | 5,507 LF | | |
| 0108 | 5325800000-E | 1510 | 8" WATER LINE | 80 LF | | |
| 0109 | 5326600000-E | 1510 | 16" WATER LINE | 483 LF | | |
| 0110 | 5329000000-E | 1510 | DUCTILE IRON WATER PIPE FITTINGS | 11,690 LB | | |
| 0111 | 5540000000-E | 1515 | 6" VALVE | 30 EA | | |
| 0112 | 5546000000-E | 1515 | 8" VALVE | 1 EA | | |
| 0113 | 5648000000-N | 1515 | RELOCATE WATER METER | 23 EA | | |
| 0114 | 5649000000-N | 1515 | RECONNECT WATER METER | 1 EA | | |
| 0115 | 5666000000-N | 1515 | FIRE HYDRANT | 4 EA | | |
| 0116 | 5673000000-E | 1515 | FIRE HYDRANT LEG | 104 LF | | |
| 0117 | 5686500000-E | 1515 | WATER SERVICE LINE | 499 LF | | |
| 0118 | 5691300000-E | 1520 | 8" SANITARY GRAVITY SEWER | 824 LF | | |
| 0119 | 5768000000-N | 1520 | SANITARY SEWER CLEAN-OUT | 11 EA | | |

County: DAVIDSON

| Line # | Item Number | Sec # | Description | Quantity | Unit Cost | Amount |
|--------|--------------|-------|---------------------------------------|--------------|-----------|--------|
| 0120 | 5768500000-E | 1520 | SEWER SERVICE LINE | 200 LF | | |
| 0121 | 5775000000-E | 1525 | 4' DIA UTILITY MANHOLE | 7 EA | | |
| 0122 | 5781000000-E | 1525 | UTILITY MANHOLE WALL 4' DIA | 15 LF | | |
| 0123 | 5800000000-E | 1530 | ABANDON 6" UTILITY PIPE | 5,311 LF | | |
| 0124 | 5801000000-E | 1530 | ABANDON 8" UTILITY PIPE | 1,607 LF | | |
| 0125 | 5816000000-N | 1530 | ABANDON UTILITY MANHOLE | 6 EA | | |
| 0126 | 5828000000-N | 1530 | REMOVE UTILITY MANHOLE | 2 EA | | |
| 0127 | 5835700000-E | 1540 | 16" ENCASEMENT PIPE | 100 LF | | |
| 0128 | 6000000000-E | 1605 | TEMPORARY SILT FENCE | 12,495 LF | | |
| 0129 | 6006000000-E | 1610 | STONE FOR EROSION CONTROL, CLASS A | 645 TON | | |
| 0130 | 6009000000-E | 1610 | STONE FOR EROSION CONTROL, CLASS B | 425 TON | | |
| 0131 | 6012000000-E | 1610 | SEDIMENT CONTROL STONE | 625 TON | | |
| 0132 | 6015000000-E | 1615 | TEMPORARY MULCHING | 17 ACR | | |
| 0133 | 6018000000-E | 1620 | SEED FOR TEMPORARY SEEDING | 1,100 LB | | |
| 0134 | 6021000000-E | 1620 | FERTILIZER FOR TEMPORARY SEEDING | 5.5 TON | | |
| 0135 | 6024000000-E | 1622 | TEMPORARY SLOPE DRAINS | 200 LF | | |
| 0136 | 6029000000-E | SP | SAFETY FENCE | 560 LF | | |

County: DAVIDSON

| Line # | Item Number | Sec # | Description | Quantity | Unit Cost | Amount |
|--------|--------------|-------|--|--------------|-----------|--------|
| 0137 | 6030000000-E | 1630 | SILT EXCAVATION | 1,100 CY | | |
| 0138 | 6036000000-E | 1631 | MATTING FOR EROSION CONTROL | 7,585 SY | | |
| 0139 | 6042000000-E | 1632 | 1/4" HARDWARE CLOTH | 360 LF | | |
| 0140 | 6071002000-E | 1642 | FLOCCULANT | 50 LB | | |
| 0141 | 6071030000-E | 1640 | COIR FIBER BAFFLE | 25 LF | | |
| 0142 | 6084000000-E | 1660 | SEEDING & MULCHING | 15 ACR | | |
| 0143 | 6087000000-E | 1660 | MOWING | 12 ACR | | |
| 0144 | 6090000000-E | 1661 | SEED FOR REPAIR SEEDING | 200 LB | | |
| 0145 | 6093000000-E | 1661 | FERTILIZER FOR REPAIR SEEDING | 0.5 TON | | |
| 0146 | 6096000000-E | 1662 | SEED FOR SUPPLEMENTAL SEEDING | 375 LB | | |
| 0147 | 6108000000-E | 1665 | FERTILIZER TOPDRESSING | 11.25 TON | | |
| 0148 | 6114500000-N | 1667 | SPECIALIZED HAND MOWING | 10 MHR | | |
| 0149 | 6114800000-N | SP | MANUAL LITTER REMOVAL | 7 MHR | | |
| 0150 | 6114900000-E | SP | LITTER DISPOSAL | 1 TON | | |
| 0151 | 6117000000-N | 1675 | RESPONSE FOR EROSION CONTROL | 25 EA | | |
| 0152 | 6117500000-N | SP | CONCRETE WASHOUT STRUCTURE | 6 EA | | |
| 0153 | 6132000000-N | SP | GENERIC EROSION CONTROL ITEM FABRIC INSERT INLET PROTECTION CLEANOUT | 549 EA | | |

County: DAVIDSON

| Line # | Item Number | Sec # | Description | Quantity | Unit Cost | Amount |
|--------|--------------|-------|---|--------------|-----------|--------|
| 0154 | 6132000000-N | SP | GENERIC EROSION CONTROL ITEM FABRIC INSERT INLET PROTECTION, TYPE 1 | 183 EA | | |
| 0155 | 7048500000-E | 1705 | PEDESTRIAN SIGNAL HEAD (16", 1 SECTION W/COUNTDOWN) | 22 EA | | |
| 0156 | 7060000000-E | 1705 | SIGNAL CABLE | 13,525 LF | | |
| 0157 | 7120000000-E | 1705 | VEHICLE SIGNAL HEAD (12", 3 SECTION) | 52 EA | | |
| 0158 | 7132000000-E | 1705 | VEHICLE SIGNAL HEAD (12", 4 SECTION) | 12 EA | | |
| 0159 | 7204000000-N | 1705 | LOUVER | 2 EA | | |
| 0160 | 7264000000-E | 1710 | MESSENGER CABLE (3/8") | 1,450 LF | | |
| 0161 | 7300000000-E | 1715 | UNPAVED TRENCHING (***** (2, 2") | 1,800 LF | | |
| 0162 | 7301000000-E | 1715 | DIRECTIONAL DRILL (***** (2, 2") | 650 LF | | |
| 0163 | 7324000000-N | 1716 | JUNCTION BOX (STANDARD SIZE) | 33 EA | | |
| 0164 | 7360000000-N | 1720 | WOOD POLE | 13 EA | | |
| 0165 | 7372000000-N | 1721 | GUY ASSEMBLY | 22 EA | | |
| 0166 | 7408000000-E | 1722 | 1" RISER WITH WEATHERHEAD | 3 EA | | |
| 0167 | 7420000000-E | 1722 | 2" RISER WITH WEATHERHEAD | 7 EA | | |
| 0168 | 7444000000-E | 1725 | INDUCTIVE LOOP SAWCUT | 2,550 LF | | |
| 0169 | 7456100000-E | 1726 | LEAD-IN CABLE (14-2) | 5,950 LF | | |
| 0170 | 7481000000-N | SP | SITE SURVEY | 4 EA | | |

County: DAVIDSON

| Line # | Item Number | Sec # | Description | Quantity | Unit Cost | Amount |
|--------|--------------|-------|---|----------|-----------|--------|
| 0171 | 7481240000-N | SP | CAMERA WITHOUT INTERNAL LOOP EMULATOR PROCESSING UNIT | 12 EA | | |
| 0172 | 7481260000-N | SP | EXTERNAL LOOP EMULATOR PROCESSING UNIT | 4 EA | | |
| 0173 | 7575142010-N | 1736 | 900MHZ SERIAL/ETHERNET SPREAD SPECTRUM RADIO | 6 EA | | |
| 0174 | 7575142060-N | 1737 | MODIFY RADIO INSTALLATION | 5 EA | | |
| 0175 | 7588000000-N | SP | METAL POLE WITH SINGLE MAST ARM | 1 EA | | |
| 0176 | 7590000000-N | SP | METAL POLE WITH DUAL MAST ARM | 5 EA | | |
| 0177 | 7613000000-N | SP | SOIL TEST | 6 EA | | |
| 0178 | 7614100000-E | SP | DRILLED PIER FOUNDATION | 54 CY | | |
| 0179 | 7631000000-N | SP | MAST ARM WITH METAL POLE DESIGN | 6 EA | | |
| 0180 | 7636000000-N | 1745 | SIGN FOR SIGNALS | 4 EA | | |
| 0181 | 7642100000-N | 1743 | TYPE I POST WITH FOUNDATION | 8 EA | | |
| 0182 | 7642200000-N | 1743 | TYPE II PEDESTAL WITH FOUNDATION | 9 EA | | |
| 0183 | 7642300000-N | 1743 | TYPE III PEDESTAL WITH FOUNDATION | 1 EA | | |
| 0184 | 7684000000-N | 1750 | SIGNAL CABINET FOUNDATION | 3 EA | | |
| 0185 | 7696000000-N | 1751 | CONTROLLERS WITH CABINET (***** (2070LX, 332) | 1 EA | | |
| 0186 | 7744000000-N | 1751 | DETECTOR CARD (TYPE 170) | 19 EA | | |
| 0187 | 7960000000-N | SP | METAL POLE FOUNDATION REMOVAL | 1 EA | | |

County: DAVIDSON

| Line # | Item Number | Sec # | Description | Quantity | Unit Cost | Amount |
|--------|--------------|-------|---|----------|-----------|--------|
| 0188 | 7972000000-N | SP | METAL POLE REMOVAL | 1 EA | | |
| 0189 | 7980000000-N | SP | GENERIC SIGNAL ITEM 2070LX CONTROLLER | 5 EA | | |
| 0190 | 7980000000-N | SP | GENERIC SIGNAL ITEM CABINET WITHOUT CONTROLLER (332) | 2 EA | | |
| 0191 | 7980000000-N | SP | GENERIC SIGNAL ITEM ETHERNET EDGE SWITCH | 6 EA | | |
| 0192 | 7980000000-N | SP | GENERIC SIGNAL ITEM LUMINAIRE ARM FOR TEMPORARY VIDEO SYSTEM | 13 EA | | |
| 0193 | 7980000000-N | SP | GENERIC SIGNAL ITEM PROTECTIVE COATING FOR DUAL MAST ARM POLE (BLACK) | 5 EA | | |
| 0194 | 7980000000-N | SP | GENERIC SIGNAL ITEM PROTECTIVE COATING FOR SINGLE MAST ARM POLE (BLACK) | 1 EA | | |
| 0195 | 7980000000-N | SP | GENERIC SIGNAL ITEM PROTECTIVE COATING FOR TYPE I PUSHBUTTON POST (BLACK) | 8 EA | | |
| 0196 | 7980000000-N | SP | GENERIC SIGNAL ITEM PROTECTIVE COATING FOR TYPE II SIGNAL PEDESTAL (BLACK) | 9 EA | | |
| 0197 | 7980000000-N | SP | GENERIC SIGNAL ITEM PROTECTIVE COATING FOR TYPE III SIGNAL PEDESTAL (BLACK) | 1 EA | | |

1332/Jul31/Q244641.75/D849536916070/E197

Total Amount Of Bid For Entire Project :

Vendor 1 of 4: KEMP SIGMON CONSTRUCTION CO INC (18313)
Call Order 004 (Proposal: C204941)

Bid Information

| | |
|--|-------------------------------------|
| Proposal County: DAVIDSON | Bid Checksum: 43F1CB099B |
| Vendor Address: P.O. Box 1270 CLAREMONT , NC , 28610 | Bid Total: \$13,458,673.90 |
| Signature Check: Tyler Dupree Sigmon | Items Total: \$13,458,673.90 |
| Time Bid Received: September 17, 2024 01:32 PM | Time Total: \$0.00 |
| Amendment Count: 1 | |

Bidding Errors:
None.

DBE GOAL SET: 5%
DBE GOAL OBT: 5.77%

Vendor 1 of 4: KEMP SIGMON CONSTRUCTION CO INC (18313)
Call Order 004 (Proposal: C204941)

Bid Bond Information

| | |
|-------------------------------------|---|
| Projects: | Bond Maximum: |
| Counties: | State of Incorporation: NY |
| Bond ID: 55DF-5EAD-067C-1876 | Agency Execution Date: 2024-09-17T00:00:00 |
| Paid by Check: No | Surety Name: Tinubu Surety |
| Bond Percent: 5% | Bond Agency Name: Atlantic Specialty Insurance Company |

DBE Load Information

Letting ID: L240917
Letting Date: 09/17/2024
Call Order: 004

DBE GOAL SET: 5%
DBE GOAL OBT: 5.77%

Contract ID: C204941
Project: STATE FUNDEDSTATE FUNDEDSTATE FUNDEDSTATE FUNDED
Bid Total: \$13,458,673.90
DBE Goal: 5.00% (\$672,933.70)

Vendor ID: 18313
Vendor Name: Kemp Sigmon Construction Co., Inc.
DBE Entered: 5.77% (\$776,830.00)

| Vendor ID | DBE Name | Is Supplier? | City/State | Goods/Service | Amount |
|-----------|------------------|--------------|--|-----------------------------------|------------|
| 7334 | RRC CONCRETE INC | False | P.O. Box 29769 CHARLOTTE, NC 28229 | SubContractor Committed | 776,830.00 |

BondID: 55DF-5EAD-067C-1876

Surety Registry Agency: Tinubu Surety

Verified?: 1

Surety Agency: Atlantic Specialty Insurance Company

Bond Execution Date: 2024-09-17T00:00:00

| Line Number | Item Number | Quantity | Unit | Unit Price | Extension Price |
|-------------------------------|--|----------|------|------------------|-----------------|
| Section 0001 ROADWAY ITEMS | | | | | |
| 0001 | 0000100000-N MOBILIZATION | 1.000 | LS | \$660,000.0000 | \$660,000.00 |
| 0002 | 0000400000-N CONSTRUCTION SURVEYING | 1.000 | LS | \$97,000.0000 | \$97,000.00 |
| 0003 | 0043000000-N GRADING | 1.000 | LS | \$1,600,000.0000 | \$1,600,000.00 |
| 0004 | 0050000000-E SUPPLEMENTARY CLEARING & GRUBBING | 1.000 | ACR | \$100.0000 | \$100.00 |
| 0005 | 0057000000-E UNDERCUT EXCAVATION | 5000.000 | CY | \$20.0000 | \$100,000.00 |
| 0006 | 0134000000-E DRAINAGE DITCH EXCAVATION | 640.000 | CY | \$15.0000 | \$9,600.00 |
| 0007 | 0195000000-E SELECT GRANULAR MATERIAL | 4810.000 | CY | \$20.0000 | \$96,200.00 |
| 0008 | 0196000000-E GEOTEXTILE FOR SOIL STABILIZATION | 5010.000 | SY | \$4.0000 | \$20,040.00 |
| 0009 | 0255000000-E GENERIC GRADING ITEM HAULING AND DISPOSAL OF PETROLEUM CONTAMINATED SOIL | 200.000 | TON | \$300.0000 | \$60,000.00 |
| 0010 | 0318000000-E FOUNDATION CONDITIONING MATERIAL, MINOR STRUCTURES | 1125.000 | TON | \$10.0000 | \$11,250.00 |
| 0011 | 0321000000-E FOUNDATION CONDITIONING GEOTEXTILE | 4668.000 | SY | \$1.0000 | \$4,668.00 |
| 0012 | 0335200000-E 15" DRAINAGE PIPE | 252.000 | LF | \$105.0000 | \$26,460.00 |
| 0013 | 0335300000-E 18" DRAINAGE PIPE | 64.000 | LF | \$115.0000 | \$7,360.00 |
| 0014 | 0335400000-E 24" DRAINAGE PIPE | 128.000 | LF | \$135.0000 | \$17,280.00 |
| 0015 | 0335500000-E 30" DRAINAGE PIPE | 40.000 | LF | \$185.0000 | \$7,400.00 |
| 0016 | 0335600000-E 36" DRAINAGE PIPE | 164.000 | LF | \$200.0000 | \$32,800.00 |
| 0017 | 0366000000-E 15" RC PIPE CULVERTS, CLASS III | 364.000 | LF | \$150.0000 | \$54,600.00 |
| 0018 | 0372000000-E 18" RC PIPE CULVERTS, CLASS III | 608.000 | LF | \$175.0000 | \$106,400.00 |
| 0019 | 0378000000-E 24" RC PIPE CULVERTS, CLASS III | 224.000 | LF | \$225.0000 | \$50,400.00 |
| 0020 | 0384000000-E 30" RC PIPE CULVERTS, CLASS III | 76.000 | LF | \$275.0000 | \$20,900.00 |
| 0021 | 0448200000-E 15" RC PIPE CULVERTS, CLASS IV | 3616.000 | LF | \$160.0000 | \$578,560.00 |
| 0022 | 0448300000-E 18" RC PIPE CULVERTS, CLASS IV | 1112.000 | LF | \$185.0000 | \$205,720.00 |
| 0023 | 0448400000-E 24" RC PIPE CULVERTS, CLASS IV | 204.000 | LF | \$235.0000 | \$47,940.00 |

| | | | | |
|------|---|--------------|------------|--------------|
| 0024 | 0449000000-E | 104.000 LF | \$170.0000 | \$17,680.00 |
| | *** RC PIPE CULVERTS, CLASS V (15") | | | |
| 0025 | 0449000000-E | 40.000 LF | \$350.0000 | \$14,000.00 |
| | *** RC PIPE CULVERTS, CLASS V (30") | | | |
| 0026 | 0588000000-E | 48.000 LF | \$115.0000 | \$5,520.00 |
| | 18" CS PIPE CULVERTS, 0.064" THICK | | | |
| 0027 | 0594000000-E | 44.000 LF | \$135.0000 | \$5,940.00 |
| | 24" CS PIPE CULVERTS, 0.064" THICK | | | |
| 0028 | 0636000000-E | 2.000 EA | \$750.0000 | \$1,500.00 |
| | *** CS PIPE ELBOWS, ***** THICK (18", 0.064") | | | |
| 0029 | 0973100000-E | 68.000 LF | \$800.0000 | \$54,400.00 |
| | *** WELDED STEEL PIPE, ***** THICK, GRADE B IN SOIL (18", 0.250") | | | |
| 0030 | 0973300000-E | 68.000 LF | \$900.0000 | \$61,200.00 |
| | *** WELDED STEEL PIPE, ***** THICK, GRADE B NOT IN SOIL (18", 0.250") | | | |
| 0031 | 0995000000-E | 3444.000 LF | \$20.0000 | \$68,880.00 |
| | PIPE REMOVAL | | | |
| 0032 | 1099500000-E | 350.000 CY | \$25.0000 | \$8,750.00 |
| | SHALLOW UNDERCUT | | | |
| 0033 | 1099700000-E | 800.000 TON | \$40.0000 | \$32,000.00 |
| | CLASS IV SUBGRADE STABILIZATION | | | |
| 0034 | 1112000000-E | 1200.000 SY | \$10.0000 | \$12,000.00 |
| | GEOTEXTILE FOR SUBGRADE STABILIZATION | | | |
| 0035 | 1121000000-E | 140.000 TON | \$75.0000 | \$10,500.00 |
| | AGGREGATE BASE COURSE | | | |
| 0036 | 1220000000-E | 500.000 TON | \$75.0000 | \$37,500.00 |
| | INCIDENTAL STONE BASE | | | |
| 0037 | 1297000000-E | 15000.000 SY | \$4.0000 | \$60,000.00 |
| | MILLING ASPHALT PAVEMENT, ****" DEPTH (1-1/2") | | | |
| 0038 | 1308000000-E | 7500.000 SY | \$7.6000 | \$57,000.00 |
| | MILLING ASPHALT PAVEMENT, ****" TO *****" (0" TO 3") | | | |
| 0039 | 1330000000-E | 7500.000 SY | \$8.3500 | \$62,625.00 |
| | INCIDENTAL MILLING | | | |
| 0040 | 1491000000-E | 7300.000 TON | \$99.0000 | \$722,700.00 |
| | ASPHALT CONC BASE COURSE, TYPE B25.0C | | | |
| 0041 | 1503000000-E | 6600.000 TON | \$97.0000 | \$640,200.00 |
| | ASPHALT CONC INTERMEDIATE COURSE, TYPE I19.0C | | | |
| 0042 | 1523000000-E | 7700.000 TON | \$90.0000 | \$693,000.00 |
| | ASPHALT CONC SURFACE COURSE, TYPE S9.5C | | | |
| 0043 | 1575000000-E | 1100.000 TON | \$695.0000 | \$764,500.00 |
| | ASPHALT BINDER FOR PLANT MIX | | | |
| 0044 | 1693000000-E | 700.000 TON | \$300.0000 | \$210,000.00 |
| | ASPHALT PLANT MIX, PAVEMENT REPAIR | | | |
| 0045 | 2000000000-N | 75.000 EA | \$260.0000 | \$19,500.00 |
| | RIGHT-OF-WAY MARKERS | | | |
| 0046 | 2022000000-E | 45.000 CY | \$25.0000 | \$1,125.00 |
| | SUBDRAIN EXCAVATION | | | |
| 0047 | 2026000000-E | 200.000 SY | \$4.0000 | \$800.00 |
| | GEOTEXTILE FOR SUBSURFACE DRAINS | | | |
| 0048 | 2036000000-E | 34.000 CY | \$125.0000 | \$4,250.00 |

SUBDRAIN COARSE AGGREGATE

| | | | | | |
|------|--|----------|----|--------------|--------------|
| 0049 | 2044000000-E | 200.000 | LF | \$20.0000 | \$4,000.00 |
| | 6" PERFORATED SUBDRAIN PIPE | | | | |
| 0050 | 2070000000-N | 1.000 | EA | \$300.0000 | \$300.00 |
| | SUBDRAIN PIPE OUTLET | | | | |
| 0051 | 2077000000-E | 6.000 | LF | \$75.0000 | \$450.00 |
| | 6" OUTLET PIPE | | | | |
| 0052 | 2253000000-E | 0.500 | CY | \$5,500.0000 | \$2,750.00 |
| | PIPE COLLARS | | | | |
| 0053 | 2286000000-N | 99.000 | EA | \$5,000.0000 | \$495,000.00 |
| | MASONRY DRAINAGE STRUCTURES | | | | |
| 0054 | 2308000000-E | 62.000 | LF | \$1,200.0000 | \$74,400.00 |
| | MASONRY DRAINAGE STRUCTURES | | | | |
| 0055 | 2364000000-N | 9.000 | EA | \$1,500.0000 | \$13,500.00 |
| | FRAME WITH TWO GRATES, STD 840.16 | | | | |
| 0056 | 2366000000-N | 4.000 | EA | \$1,500.0000 | \$6,000.00 |
| | FRAME WITH TWO GRATES, STD 840.24 | | | | |
| 0057 | 2367000000-N | 8.000 | EA | \$1,500.0000 | \$12,000.00 |
| | FRAME WITH TWO GRATES, STD 840.29 | | | | |
| 0058 | 2374000000-N | 12.000 | EA | \$1,500.0000 | \$18,000.00 |
| | FRAME WITH GRATE & HOOD, STD 840.03, TYPE ** (E) | | | | |
| 0059 | 2374000000-N | 32.000 | EA | \$1,500.0000 | \$48,000.00 |
| | FRAME WITH GRATE & HOOD, STD 840.03, TYPE ** (F) | | | | |
| 0060 | 2374000000-N | 29.000 | EA | \$1,500.0000 | \$43,500.00 |
| | FRAME WITH GRATE & HOOD, STD 840.03, TYPE ** (G) | | | | |
| 0061 | 2396000000-N | 5.000 | EA | \$1,500.0000 | \$7,500.00 |
| | FRAME WITH COVER, STD 840.54 | | | | |
| 0062 | 2440000000-N | 1.000 | EA | \$2,500.0000 | \$2,500.00 |
| | CONCRETE TRANSITIONAL SECTION FOR CATCH BASIN | | | | |
| 0063 | 2535000000-E | 900.000 | LF | \$35.0000 | \$31,500.00 |
| | **" X **" CONCRETE CURB (8" X 18") | | | | |
| 0064 | 2542000000-E | 2250.000 | LF | \$27.0000 | \$60,750.00 |
| | 1'-6" CONCRETE CURB & GUTTER | | | | |
| 0065 | 2549000000-E | 8100.000 | LF | \$29.0000 | \$234,900.00 |
| | 2'-6" CONCRETE CURB & GUTTER | | | | |
| 0066 | 2570000000-N | 2.000 | EA | \$3,800.0000 | \$7,600.00 |
| | MODIFIED CONCRETE FLUME | | | | |
| 0067 | 2580000000-E | 1000.000 | LF | \$28.0000 | \$28,000.00 |
| | CONCRETE VALLEY GUTTER | | | | |
| 0068 | 2591000000-E | 2950.000 | SY | \$58.0000 | \$171,100.00 |
| | 4" CONCRETE SIDEWALK | | | | |
| 0069 | 2605000000-N | 32.000 | EA | \$2,290.0000 | \$73,280.00 |
| | CONCRETE CURB RAMPS | | | | |
| 0070 | 2612000000-E | 500.000 | SY | \$93.0000 | \$46,500.00 |
| | 6" CONCRETE DRIVEWAY | | | | |
| 0071 | 2619000000-E | 11.000 | SY | \$200.0000 | \$2,200.00 |
| | 4" CONCRETE PAVED DITCH | | | | |
| 0072 | 2655000000-E | 1100.000 | SY | \$110.0000 | \$121,000.00 |
| | 5" MONOLITHIC CONCRETE ISLANDS (KEYED IN) | | | | |

| | | | | |
|------|--|-------------|---------------|-------------|
| 0073 | 2800000000-N | 1.000 EA | \$2,500.0000 | \$2,500.00 |
| | ADJUSTMENT OF CATCH BASINS | | | |
| 0074 | 3536000000-E | 220.000 LF | \$20.0000 | \$4,400.00 |
| | CHAIN LINK FENCE, 48" FABRIC | | | |
| 0075 | 3542000000-E | 19.000 EA | \$150.0000 | \$2,850.00 |
| | METAL LINE POSTS FOR 48" CHAIN LINK FENCE | | | |
| 0076 | 3548000000-E | 2.000 EA | \$250.0000 | \$500.00 |
| | METAL TERMINAL POSTS FOR 48" CHAIN LINK FENCE | | | |
| 0077 | 3628000000-E | 380.000 TON | \$120.0000 | \$45,600.00 |
| | RIP RAP, CLASS I | | | |
| 0078 | 3649000000-E | 4.000 TON | \$1,000.0000 | \$4,000.00 |
| | RIP RAP, CLASS B | | | |
| 0079 | 3656000000-E | 1129.000 SY | \$4.0000 | \$4,516.00 |
| | GEOTEXTILE FOR DRAINAGE | | | |
| 0080 | 4072000000-E | 750.000 LF | \$9.9900 | \$7,492.50 |
| | SUPPORTS, 3-LB STEEL U-CHANNEL | | | |
| 0081 | 4102000000-N | 27.000 EA | \$65.0000 | \$1,755.00 |
| | SIGN ERECTION, TYPE E | | | |
| 0082 | 4108000000-N | 4.000 EA | \$75.0000 | \$300.00 |
| | SIGN ERECTION, TYPE F | | | |
| 0083 | 4116100000-N | 1.000 EA | \$150.0000 | \$150.00 |
| | SIGN ERECTION, RELOCATE TYPE **** (GROUND MOUNTED) (E) | | | |
| 0084 | 4155000000-N | 37.000 EA | \$1.0000 | \$37.00 |
| | DISPOSAL OF SIGN SYSTEM, U-CHANNEL | | | |
| 0085 | 4400000000-E | 264.000 SF | \$7.7500 | \$2,046.00 |
| | WORK ZONE SIGNS (STATIONARY) | | | |
| 0086 | 4405000000-E | 242.000 SF | \$8.6500 | \$2,093.30 |
| | WORK ZONE SIGNS (PORTABLE) | | | |
| 0087 | 4410000000-E | 10.000 SF | \$8.8500 | \$88.50 |
| | WORK ZONE SIGNS (BARRICADE MOUNTED) | | | |
| 0088 | 4415000000-N | 4.000 EA | \$14,000.0000 | \$56,000.00 |
| | FLASHING ARROW BOARD | | | |
| 0089 | 4420000000-N | 2.000 EA | \$9,800.0000 | \$19,600.00 |
| | PORTABLE CHANGEABLE MESSAGE SIGN | | | |
| 0090 | 4430000000-N | 300.000 EA | \$100.0000 | \$30,000.00 |
| | DRUMS | | | |
| 0091 | 4435000000-N | 100.000 EA | \$50.0000 | \$5,000.00 |
| | CONES | | | |
| 0092 | 4445000000-E | 64.000 LF | \$25.0000 | \$1,600.00 |
| | BARRICADES (TYPE III) | | | |
| 0093 | 4447000000-E | 30.000 LF | \$68.0000 | \$2,040.00 |
| | PEDESTRIAN CHANNELIZING DEVICES | | | |
| 0094 | 4455000000-N | 60.000 DAY | \$750.0000 | \$45,000.00 |
| | FLAGGER | | | |
| 0095 | 4480000000-N | 2.000 EA | \$20,000.0000 | \$40,000.00 |
| | TMA | | | |
| 0096 | 4516000000-N | 100.000 EA | \$100.0000 | \$10,000.00 |
| | SKINNY DRUM | | | |
| 0097 | 4600000000-N | 2.000 EA | \$165.0000 | \$330.00 |

GENERIC TRAFFIC CONTROL ITEM AUDIBLE WARNING DEVICE

| | | | | |
|------|---|--------------|---------------|----------------|
| 0098 | 4685000000-E | 18828.000 LF | \$0.7000 | \$13,179.60 |
| | THERMOPLASTIC PAVEMENT MARKING LINES (4", 90 MILS) | | | |
| 0099 | 4695000000-E | 4130.000 LF | \$2.7500 | \$11,357.50 |
| | THERMOPLASTIC PAVEMENT MARKING LINES (8", 90 MILS) | | | |
| 0100 | 4709000000-E | 700.000 LF | \$10.0000 | \$7,000.00 |
| | THERMOPLASTIC PAVEMENT MARKING LINES (24", 90 MILS) | | | |
| 0101 | 4725000000-E | 82.000 EA | \$75.0000 | \$6,150.00 |
| | THERMOPLASTIC PAVEMENT MARKING SYMBOL (90 MILS) | | | |
| 0102 | 4810000000-E | 26231.000 LF | \$0.2500 | \$6,557.75 |
| | PAINT PAVEMENT MARKING LINES (4") | | | |
| 0103 | 4820000000-E | 4276.000 LF | \$0.7500 | \$3,207.00 |
| | PAINT PAVEMENT MARKING LINES (8") | | | |
| 0104 | 4835000000-E | 950.000 LF | \$4.0000 | \$3,800.00 |
| | PAINT PAVEMENT MARKING LINES (24") | | | |
| 0105 | 4840000000-N | 8.000 EA | \$25.0000 | \$200.00 |
| | PAINT PAVEMENT MARKING CHARACTER | | | |
| 0106 | 4845000000-N | 115.000 EA | \$25.0000 | \$2,875.00 |
| | PAINT PAVEMENT MARKING SYMBOL | | | |
| 0107 | 5325600000-E | 5507.000 LF | \$200.0000 | \$1,101,400.00 |
| | 6" WATER LINE | | | |
| 0108 | 5325800000-E | 80.000 LF | \$400.0000 | \$32,000.00 |
| | 8" WATER LINE | | | |
| 0109 | 5326600000-E | 483.000 LF | \$550.0000 | \$265,650.00 |
| | 16" WATER LINE | | | |
| 0110 | 5329000000-E | 11690.000 LB | \$20.0000 | \$233,800.00 |
| | DUCTILE IRON WATER PIPE FITTINGS | | | |
| 0111 | 5540000000-E | 30.000 EA | \$5,000.0000 | \$150,000.00 |
| | 6" VALVE | | | |
| 0112 | 5546000000-E | 1.000 EA | \$5,500.0000 | \$5,500.00 |
| | 8" VALVE | | | |
| 0113 | 5648000000-N | 23.000 EA | \$3,500.0000 | \$80,500.00 |
| | RELOCATE WATER METER | | | |
| 0114 | 5649000000-N | 1.000 EA | \$2,000.0000 | \$2,000.00 |
| | RECONNECT WATER METER | | | |
| 0115 | 5666000000-N | 4.000 EA | \$10,000.0000 | \$40,000.00 |
| | FIRE HYDRANT | | | |
| 0116 | 5673000000-E | 104.000 LF | \$175.0000 | \$18,200.00 |
| | FIRE HYDRANT LEG | | | |
| 0117 | 5686500000-E | 499.000 LF | \$150.0000 | \$74,850.00 |
| | WATER SERVICE LINE | | | |
| 0118 | 5691300000-E | 824.000 LF | \$275.0000 | \$226,600.00 |
| | 8" SANITARY GRAVITY SEWER | | | |
| 0119 | 5768000000-N | 11.000 EA | \$5,000.0000 | \$55,000.00 |
| | SANITARY SEWER CLEAN-OUT | | | |
| 0120 | 5768500000-E | 200.000 LF | \$350.0000 | \$70,000.00 |
| | SEWER SERVICE LINE | | | |
| 0121 | 5775000000-E | 7.000 EA | \$4,000.0000 | \$28,000.00 |
| | 4' DIA UTILITY MANHOLE | | | |

| | | | | | |
|------|------------------------------------|-----------|-----|--------------|--------------|
| 0122 | 5781000000-E | 15.000 | LF | \$750.0000 | \$11,250.00 |
| | UTILITY MANHOLE WALL 4' DIA | | | | |
| 0123 | 5800000000-E | 5311.000 | LF | \$20.0000 | \$106,220.00 |
| | ABANDON 6" UTILITY PIPE | | | | |
| 0124 | 5801000000-E | 1607.000 | LF | \$20.0000 | \$32,140.00 |
| | ABANDON 8" UTILITY PIPE | | | | |
| 0125 | 5816000000-N | 6.000 | EA | \$5,000.0000 | \$30,000.00 |
| | ABANDON UTILITY MANHOLE | | | | |
| 0126 | 5828000000-N | 2.000 | EA | \$7,500.0000 | \$15,000.00 |
| | REMOVE UTILITY MANHOLE | | | | |
| 0127 | 5835700000-E | 100.000 | LF | \$1,000.0000 | \$100,000.00 |
| | 16" ENCASEMENT PIPE | | | | |
| 0128 | 6000000000-E | 12495.000 | LF | \$3.0500 | \$38,109.75 |
| | TEMPORARY SILT FENCE | | | | |
| 0129 | 6006000000-E | 645.000 | TON | \$50.0000 | \$32,250.00 |
| | STONE FOR EROSION CONTROL, CLASS A | | | | |
| 0130 | 6009000000-E | 425.000 | TON | \$50.0000 | \$21,250.00 |
| | STONE FOR EROSION CONTROL, CLASS B | | | | |
| 0131 | 6012000000-E | 625.000 | TON | \$50.0000 | \$31,250.00 |
| | SEDIMENT CONTROL STONE | | | | |
| 0132 | 6015000000-E | 17.000 | ACR | \$1,350.0000 | \$22,950.00 |
| | TEMPORARY MULCHING | | | | |
| 0133 | 6018000000-E | 1100.000 | LB | \$3.0000 | \$3,300.00 |
| | SEED FOR TEMPORARY SEEDING | | | | |
| 0134 | 6021000000-E | 5.500 | TON | \$1,250.0000 | \$6,875.00 |
| | FERTILIZER FOR TEMPORARY SEEDING | | | | |
| 0135 | 6024000000-E | 200.000 | LF | \$10.0000 | \$2,000.00 |
| | TEMPORARY SLOPE DRAINS | | | | |
| 0136 | 6029000000-E | 560.000 | LF | \$2.2500 | \$1,260.00 |
| | SAFETY FENCE | | | | |
| 0137 | 6030000000-E | 1100.000 | CY | \$15.0000 | \$16,500.00 |
| | SILT EXCAVATION | | | | |
| 0138 | 6036000000-E | 7585.000 | SY | \$1.6000 | \$12,136.00 |
| | MATTING FOR EROSION CONTROL | | | | |
| 0139 | 6042000000-E | 360.000 | LF | \$6.0000 | \$2,160.00 |
| | 1/4" HARDWARE CLOTH | | | | |
| 0140 | 6071002000-E | 50.000 | LB | \$16.0000 | \$800.00 |
| | FLOCCULANT | | | | |
| 0141 | 6071030000-E | 25.000 | LF | \$8.0000 | \$200.00 |
| | COIR FIBER BAFFLE | | | | |
| 0142 | 6084000000-E | 15.000 | ACR | \$2,450.0000 | \$36,750.00 |
| | SEEDING & MULCHING | | | | |
| 0143 | 6087000000-E | 12.000 | ACR | \$225.0000 | \$2,700.00 |
| | MOWING | | | | |
| 0144 | 6090000000-E | 200.000 | LB | \$8.0000 | \$1,600.00 |
| | SEED FOR REPAIR SEEDING | | | | |
| 0145 | 6093000000-E | 0.500 | TON | \$2,100.0000 | \$1,050.00 |
| | FERTILIZER FOR REPAIR SEEDING | | | | |
| 0146 | 6096000000-E | 375.000 | LB | \$7.0000 | \$2,625.00 |

SEED FOR SUPPLEMENTAL SEEDING

| | | | | |
|------|--|--------------|--------------|-------------|
| 0147 | 6108000000-E | 11.250 TON | \$1,400.0000 | \$15,750.00 |
| | FERTILIZER TOPDRESSING | | | |
| 0148 | 6114500000-N | 10.000 MHR | \$95.0000 | \$950.00 |
| | SPECIALIZED HAND MOWING | | | |
| 0149 | 6114800000-N | 7.000 MHR | \$75.0000 | \$525.00 |
| | MANUAL LITTER REMOVAL | | | |
| 0150 | 6114900000-E | 1.000 TON | \$500.0000 | \$500.00 |
| | LITTER DISPOSAL | | | |
| 0151 | 6117000000-N | 25.000 EA | \$350.0000 | \$8,750.00 |
| | RESPONSE FOR EROSION CONTROL | | | |
| 0152 | 6117500000-N | 6.000 EA | \$2,000.0000 | \$12,000.00 |
| | CONCRETE WASHOUT STRUCTURE | | | |
| 0153 | 6132000000-N | 549.000 EA | \$140.0000 | \$76,860.00 |
| | GENERIC EROSION CONTROL ITEM FABRIC INSERT INLET PROTECTION CLEANOUT | | | |
| 0154 | 6132000000-N | 183.000 EA | \$140.0000 | \$25,620.00 |
| | GENERIC EROSION CONTROL ITEM FABRIC INSERT INLET PROTECTION, TYPE 1 | | | |
| 0155 | 7048500000-E | 22.000 EA | \$1,500.0000 | \$33,000.00 |
| | PEDESTRIAN SIGNAL HEAD (16", 1 SECTION W/COUNTDOWN) | | | |
| 0156 | 7060000000-E | 13525.000 LF | \$5.0000 | \$67,625.00 |
| | SIGNAL CABLE | | | |
| 0157 | 7120000000-E | 52.000 EA | \$1,300.0000 | \$67,600.00 |
| | VEHICLE SIGNAL HEAD (12", 3 SECTION) | | | |
| 0158 | 7132000000-E | 12.000 EA | \$1,500.0000 | \$18,000.00 |
| | VEHICLE SIGNAL HEAD (12", 4 SECTION) | | | |
| 0159 | 7204000000-N | 2.000 EA | \$250.0000 | \$500.00 |
| | LOUVER | | | |
| 0160 | 7264000000-E | 1450.000 LF | \$10.0000 | \$14,500.00 |
| | MESSENGER CABLE (3/8") | | | |
| 0161 | 7300000000-E | 1800.000 LF | \$20.0000 | \$36,000.00 |
| | UNPAVED TRENCHING (***** (2, 2")) | | | |
| 0162 | 7301000000-E | 650.000 LF | \$50.0000 | \$32,500.00 |
| | DIRECTIONAL DRILL (***** (2, 2")) | | | |
| 0163 | 7324000000-N | 33.000 EA | \$750.0000 | \$24,750.00 |
| | JUNCTION BOX (STANDARD SIZE) | | | |
| 0164 | 7360000000-N | 13.000 EA | \$1,800.0000 | \$23,400.00 |
| | WOOD POLE | | | |
| 0165 | 7372000000-N | 22.000 EA | \$1,500.0000 | \$33,000.00 |
| | GUY ASSEMBLY | | | |
| 0166 | 7408000000-E | 3.000 EA | \$600.0000 | \$1,800.00 |
| | 1" RISER WITH WEATHERHEAD | | | |
| 0167 | 7420000000-E | 7.000 EA | \$1,100.0000 | \$7,700.00 |
| | 2" RISER WITH WEATHERHEAD | | | |
| 0168 | 7444000000-E | 2550.000 LF | \$15.0000 | \$38,250.00 |
| | INDUCTIVE LOOP SAWCUT | | | |
| 0169 | 7456100000-E | 5950.000 LF | \$4.0000 | \$23,800.00 |
| | LEAD-IN CABLE (14-2) | | | |
| 0170 | 7481000000-N | 4.000 EA | \$1,000.0000 | \$4,000.00 |
| | SITE SURVEY | | | |

| | | | | |
|------|---|-----------|---------------|--------------|
| 0171 | 7481240000-N | 12.000 EA | \$3,500.0000 | \$42,000.00 |
| | CAMERA WITHOUT INTERNAL LOOP EMULATOR PROCESSING UNIT | | | |
| 0172 | 7481260000-N | 4.000 EA | \$5,200.0000 | \$20,800.00 |
| | EXTERNAL LOOP EMULATOR PROCESSING UNIT | | | |
| 0173 | 7575142010-N | 6.000 EA | \$6,000.0000 | \$36,000.00 |
| | 900MHZ SERIAL/ETHERNET SPREAD SPECTRUM RADIO | | | |
| 0174 | 7575142060-N | 5.000 EA | \$1,400.0000 | \$7,000.00 |
| | MODIFY RADIO INSTALLATION | | | |
| 0175 | 7588000000-N | 1.000 EA | \$30,000.0000 | \$30,000.00 |
| | METAL POLE WITH SINGLE MAST ARM | | | |
| 0176 | 7590000000-N | 5.000 EA | \$50,000.0000 | \$250,000.00 |
| | METAL POLE WITH DUAL MAST ARM | | | |
| 0177 | 7613000000-N | 6.000 EA | \$2,500.0000 | \$15,000.00 |
| | SOIL TEST | | | |
| 0178 | 7614100000-E | 54.000 CY | \$2,000.0000 | \$108,000.00 |
| | DRILLED PIER FOUNDATION | | | |
| 0179 | 7631000000-N | 6.000 EA | \$200.0000 | \$1,200.00 |
| | MAST ARM WITH METAL POLE DESIGN | | | |
| 0180 | 7636000000-N | 3.000 EA | \$500.0000 | \$1,500.00 |
| | SIGN FOR SIGNALS | | | |
| 0181 | 7642100000-N | 8.000 EA | \$2,200.0000 | \$17,600.00 |
| | TYPE I POST WITH FOUNDATION | | | |
| 0182 | 7642200000-N | 9.000 EA | \$3,000.0000 | \$27,000.00 |
| | TYPE II PEDESTAL WITH FOUNDATION | | | |
| 0183 | 7642300000-N | 1.000 EA | \$5,600.0000 | \$5,600.00 |
| | TYPE III PEDESTAL WITH FOUNDATION | | | |
| 0184 | 7684000000-N | 3.000 EA | \$2,500.0000 | \$7,500.00 |
| | SIGNAL CABINET FOUNDATION | | | |
| 0185 | 7696000000-N | 1.000 EA | \$27,600.0000 | \$27,600.00 |
| | CONTROLLERS WITH CABINET (***** (2070LX, 332) | | | |
| 0186 | 7744000000-N | 19.000 EA | \$335.0000 | \$6,365.00 |
| | DETECTOR CARD (TYPE 170) | | | |
| 0187 | 7960000000-N | 1.000 EA | \$2,500.0000 | \$2,500.00 |
| | METAL POLE FOUNDATION REMOVAL | | | |
| 0188 | 7972000000-N | 1.000 EA | \$700.0000 | \$700.00 |
| | METAL POLE REMOVAL | | | |
| 0189 | 7980000000-N | 5.000 EA | \$6,600.0000 | \$33,000.00 |
| | GENERIC SIGNAL ITEM 2070LX CONTROLLER | | | |
| 0190 | 7980000000-N | 2.000 EA | \$22,000.0000 | \$44,000.00 |
| | GENERIC SIGNAL ITEM CABINET WITHOUT CONTROLLER (332) | | | |
| 0191 | 7980000000-N | 6.000 EA | \$2,100.0000 | \$12,600.00 |
| | GENERIC SIGNAL ITEM ETHERNET EDGE SWITCH | | | |
| 0192 | 7980000000-N | 13.000 EA | \$1,000.0000 | \$13,000.00 |
| | GENERIC SIGNAL ITEM LUMINAIRE ARM FOR TEMPORARY VIDEO SYSTEM | | | |
| 0193 | 7980000000-N | 5.000 EA | \$7,200.0000 | \$36,000.00 |
| | GENERIC SIGNAL ITEM PROTECTIVE COATING FOR DUAL MAST ARM POLE (BLACK) | | | |
| 0194 | 7980000000-N | 1.000 EA | \$2,900.0000 | \$2,900.00 |
| | GENERIC SIGNAL ITEM PROTECTIVE COATING FOR SINGLE MAST ARM POLE (BLACK) | | | |
| 0195 | 7980000000-N | 8.000 EA | \$100.0000 | \$800.00 |

GENERIC SIGNAL ITEM PROTECTIVE COATING FOR TYPE I PUSHBUTTON POST (BLACK)

| | | | | |
|------|--------------|----------|------------|------------|
| 0196 | 7980000000-N | 9.000 EA | \$150.0000 | \$1,350.00 |
|------|--------------|----------|------------|------------|

GENERIC SIGNAL ITEM PROTECTIVE COATING FOR TYPE II SIGNAL PEDESTAL (BLACK)

| | | | | |
|------|--------------|----------|------------|----------|
| 0197 | 7980000000-N | 1.000 EA | \$200.0000 | \$200.00 |
|------|--------------|----------|------------|----------|

GENERIC SIGNAL ITEM PROTECTIVE COATING FOR TYPE III SIGNAL PEDESTAL (BLACK)

| | | | | |
|--------------------|--|--|--|-----------------|
| Section 0001 Total | | | | \$13,458,673.90 |
|--------------------|--|--|--|-----------------|

| | | | | |
|------------|--|--|--|-----------------|
| Item Total | | | | \$13,458,673.90 |
|------------|--|--|--|-----------------|

ELECTRONIC BID SUBMISSION

By submitting this bid electronically, I hereby acknowledge that all requirements included in the hard copy proposal, addendum, amendments, plans, standard specifications, supplemental specifications and special provisions are part of the bid and contract. Further, I acknowledge that I have read, understand, accept, acknowledge and agree to comply with all statements in this electronic bid.

=====

NON-COLLUSION, DEBARMENT AND GIFT BAN CERTIFICATION

The prequalified bidder declares (or certifies, verifies, or states) under penalty of perjury under the laws of the United States that neither he, nor any official, agent or employee has entered into any agreement, participated in any collusion, or otherwise taken any action which is in restraint of free competitive bidding in connection with any bid or contract, that the prequalified bidder has not been convicted of violating N.C.G.S. §133-24 within the last three years, and that the prequalified bidder intends to do the work with his own bonafide employees or subcontractors and will not bid for the benefit of another contractor.

By submitting this non-collusion, debarment and gift ban certification, the Contractor is attesting his status under penalty of perjury under the laws of the United States in accordance with the Debarment Certification attached, provided that the Debarment Certification also includes any required statements concerning exceptions that are applicable.

N.C.G.S. §133-32 and Executive Order 24 prohibit the offer to, or acceptance by, any State Employee of any gift from anyone with a contract with the State, or from any person seeking to do business with the State. By execution of any response in this procurement, you attest, for your entire organization and its employees or agents, that you are not aware that any such gift has been offered, accepted, or promised by any employees of your organization.

DEBARMENT CERTIFICATION OF PREQUALIFIED BIDDER

Conditions for certification:

1. The prequalified bidder shall provide immediate written notice to the Department if at any time the bidder learns that his certification was erroneous when he submitted his debarment certification or explanation that is file with the Department, or has become erroneous because of changed circumstances.
2. The terms covered transaction, debarred, suspended, ineligible, lower tier

covered transaction, participant, person, primary covered transaction, principal, proposal, and voluntarily excluded, as used in this provision, have the meanings set out in the Definitions and Coverage sections of the rules implementing Executive Order 12549. A copy of the Federal Rules requiring this certification and detailing the definitions and coverages may be obtained from the Contract Officer of the Department.

3. The prequalified bidder agrees by submitting this form, that he will not knowingly enter into any lower tier covered transaction with a person who is debarred, suspended, declared ineligible, or voluntarily excluded from participation in NCDOT contracts, unless authorized by the Department.

4. For Federal Aid projects, the prequalified bidder further agrees that by submitting this form he will include the Federal- Aid Provision titled Required Contract Provisions Federal-Aid Construction Contract (Form FHWA PR 1273) provided by the Department, without subsequent modification, in all lower tier covered transactions.

5. The prequalified bidder may rely upon a certification of a participant in a lower tier covered transaction that he is not debarred, suspended, ineligible, or voluntarily excluded from the covered transaction, unless he knows that the certification is erroneous. The bidder may decide the method and frequency by which he will determine the eligibility of his subcontractors.

6. Nothing contained in the foregoing shall be construed to require establishment of a system of records in order to render in good faith the certification required by this provision. The knowledge and information of a participant is not required to exceed that which is normally possessed by a prudent person in the ordinary course of business dealings.

7. Except as authorized in paragraph 6 herein, the Department may terminate any contract if the bidder knowingly enters into a lower tier covered transaction with a person who is suspended, debarred, ineligible, or voluntarily excluded from participation in this transaction, in addition to other remedies available by the Federal Government.

DEBARMENT CERTIFICATION

The prequalified bidder certifies to the best of his knowledge and belief, that he and his principals:

a. Are not presently debarred, suspended, proposed for debarment, declared ineligible, or voluntarily excluded from covered transactions by any Federal department or agency;

b. Have not within a three-year period preceding this proposal been convicted of or had a civil judgment rendered against them for commission of fraud or a criminal offense in connection with obtaining, attempting to obtain, or performing a public (Federal, State or local) transaction or contract under a public transaction; violation of Federal or State antitrust statutes or

commission of embezzlement, theft, forgery, bribery, falsification or destruction of records; making false statements; or receiving stolen property;

c. Are not presently indicted for or otherwise criminally or civilly charged by a governmental entity (Federal, State or local) with commission of any of the offenses enumerated in paragraph b. of this certification; and

d. Have not within a three-year period preceding this proposal had one or more public transactions (Federal, State or local) terminated for cause or default.

e. Will submit a revised Debarment Certification immediately if his status changes and will show in his bid proposal an explanation for the change in status.

If the prequalified bidder cannot certify that he is not debarred, he shall provide an explanation with this submittal. An explanation will not necessarily result in denial of participation in a contract.

Failure to submit a non-collusion and debarment certification will result in the prequalified bidder's bid being considered non-responsive.

EXPLANATION:

=====

Award Limits on Multiple Projects

By answering YES to this statement, the bidder acknowledges that they are using the award limits on multiple projects? **Yes** **No**

A bidder who desires to bid on more than one project on which bids are to be opened on the same date, and who also desires to avoid receiving an award of more projects than he is equipped to handle, may bid on any number of projects but may limit the total amount of work awarded to him on selected projects by completing the AWARD LIMITS ON MULTIPLE PROJECTS.

The Award Limits on Multiple Projects must be filled in on each project bid for which the Bidder desires protection.

It is the desire of the Bidder to be awarded contracts, the value of which will not exceed a total of for those

projects indicated herein, for which bids will be opened on (MM/DD/YY)

The Award Limits shall apply to the following projects:

Contract Number
County

Contract Number
County

Contract Number
County

Contract Number
County

Contract Number
County

Contract Number
County

It is agreed that if I am (we are) the low Bidder(s) on indicated projects, the total value of which is more than the above stipulated award limits, the Board of Transportation will award me (us) projects from among those indicated

that have a total value not to exceed the award limit and will result in the lowest total bids to the Department of Transportation.

DBE List Summary

Project: STATE FUNDED
Bid Total: 13,458,673.90

Bidder ID: 18313
Business Name: Kemp Sigmon Construction Co.,
Inc.

Goal: 5.00% (672,933.70)
Total Entered: 5.77% (776,830.00)

| ID | Name | Supp?/Dist? | Item Count | Amount | Is Complete? |
|-----------|------------------|--------------------|-------------------|---------------|---------------------|
| 7334 | RRC CONCRETE INC | No | 10 | 776,830.00 | True |

Name: RRC CONCRETE INC ID: 7334

Address: P.O. Box 29769 CHARLOTTE, NC 28229

Used As: SubContractor DBE Items Total:\$776,830.00

Items for RRC CONCRETE INC

| 0001 ROADWAY ITEMS | | | | | |
|-----------------------|---|----------|----|--------------|--------------|
| 0063 | 2535000000-E | 900.000 | LF | \$35.0000 | \$31,500.00 |
| | **" X **" CONCRETE CURB (8" X 18") | | | | |
| 0064 | 2542000000-E | 2250.000 | LF | \$27.0000 | \$60,750.00 |
| | 1'-6" CONCRETE CURB & GUTTER | | | | |
| 0065 | 2549000000-E | 8100.000 | LF | \$29.0000 | \$234,900.00 |
| | 2'-6" CONCRETE CURB & GUTTER | | | | |
| 0066 | 2570000000-N | 2.000 | EA | \$3,800.0000 | \$7,600.00 |
| | MODIFIED CONCRETE FLUME | | | | |
| 0067 | 2580000000-E | 1000.000 | LF | \$28.0000 | \$28,000.00 |
| | CONCRETE VALLEY GUTTER | | | | |
| 0068 | 2591000000-E | 2950.000 | SY | \$58.0000 | \$171,100.00 |
| | 4" CONCRETE SIDEWALK | | | | |
| 0069 | 2605000000-N | 32.000 | EA | \$2,290.0000 | \$73,280.00 |
| | CONCRETE CURB RAMPS | | | | |
| 0070 | 2612000000-E | 500.000 | SY | \$93.0000 | \$46,500.00 |
| | 6" CONCRETE DRIVEWAY | | | | |
| 0071 | 2619000000-E | 11.000 | SY | \$200.0000 | \$2,200.00 |
| | 4" CONCRETE PAVED DITCH | | | | |
| 0072 | 2655000000-E | 1100.000 | SY | \$110.0000 | \$121,000.00 |
| | 5" MONOLITHIC CONCRETE ISLANDS (KEYED IN) | | | | |
| Section 0001 Total | | | | | \$776,830.00 |
| Item Total | | | | | \$776,830.00 |

THIS PROPOSAL CONTAINS THE FOLLOWING ERRORS/WARNINGS (IF ANY)

This Bid contains 1 amendment files

1 09/11/2024 MODIFY ITEM

Electronic Bid Submission

By submitting this bid electronically, I hereby acknowledge that all requirements included in the hard copy proposal, addendum, amendments, plans, standard specifications, supplemental specifications and special provisions are part of the bid and contract. Further, I acknowledge that I have read, understand, accept, acknowledge and agree to comply with all statements in this electronic bid.

I hereby certify that I have the authority to submit this bid.

Signature _____

Agency _____

Date _____

Signature _____

Agency _____

Date _____

Signature _____

Agency _____

Date _____

Attachments

Failure to complete and attach the Fuel Usage Factor Adjustment Form will result in using 2.90 gallons per ton as the Fuel Usage Factor for Diesel for the asphalt items included on the form. The contractor will not be permitted to change the option after the bids are submitted.

NOTE: The maximum upload limit is 5 MB. [_Fuel Usage Factor Adjustment Form JTR C204941.pdf](#) Verify

| Line # | ItemNumber | Sec # | Description | Quantity Unit | Unit Bid Price | Amount Bid |
|----------------------|--------------|-------|--|---------------|----------------|--------------|
| ROADWAY ITEMS | | | | | | |
| 0001 | 0000100000-N | 800 | MOBILIZATION | LUMP SUM | 660,000.00 | 660,000.00 |
| 0002 | 0000400000-N | 801 | CONSTRUCTION SURVEYING | LUMP SUM | 97,000.00 | 97,000.00 |
| 0003 | 0043000000-N | 226 | GRADING | LUMP SUM | 1,600,000.00 | 1,600,000.00 |
| 0004 | 0050000000-E | 226 | SUPPLEMENTARY CLEARING & GRUBBING | 1 ACR | 100.00 | 100.00 |
| 0005 | 0057000000-E | 226 | UNDERCUT EXCAVATION | 5,000 CY | 20.00 | 100,000.00 |
| 0006 | 0134000000-E | 240 | DRAINAGE DITCH EXCAVATION | 640 CY | 15.00 | 9,600.00 |
| 0007 | 0195000000-E | 265 | SELECT GRANULAR MATERIAL | 4,810 CY | 20.00 | 96,200.00 |
| 0008 | 0196000000-E | 270 | GEOTEXTILE FOR SOIL STABILIZATION | 5,010 SY | 4.00 | 20,040.00 |
| 0009 | 0255000000-E | SP | GENERIC GRADING ITEM HAULING AND DISPOSAL OF PETROLEUM CONTAMINATED SOIL | 200 TON | 300.00 | 60,000.00 |
| 0010 | 0318000000-E | 300 | FOUNDATION CONDITIONING MATERIAL, MINOR STRUCTURES | 1,125 TON | 10.00 | 11,250.00 |
| 0011 | 0321000000-E | 300 | FOUNDATION CONDITIONING GEOTEXTILE | 4,668 SY | 1.00 | 4,668.00 |
| 0012 | 0335200000-E | 305 | 15" DRAINAGE PIPE | 252 LF | 105.00 | 26,460.00 |
| 0013 | 0335300000-E | 305 | 18" DRAINAGE PIPE | 64 LF | 115.00 | 7,360.00 |
| 0014 | 0335400000-E | 305 | 24" DRAINAGE PIPE | 128 LF | 135.00 | 17,280.00 |
| 0015 | 0335500000-E | 305 | 30" DRAINAGE PIPE | 40 LF | 185.00 | 7,400.00 |
| 0016 | 0335600000-E | 305 | 36" DRAINAGE PIPE | 164 LF | 200.00 | 32,800.00 |
| 0017 | 0366000000-E | 310 | 15" RC PIPE CULVERTS, CLASS III | 364 LF | 150.00 | 54,600.00 |
| 0018 | 0372000000-E | 310 | 18" RC PIPE CULVERTS, CLASS III | 608 LF | 175.00 | 106,400.00 |
| 0019 | 0378000000-E | 310 | 24" RC PIPE CULVERTS, CLASS III | 224 LF | 225.00 | 50,400.00 |
| 0020 | 0384000000-E | 310 | 30" RC PIPE CULVERTS, CLASS III | 76 LF | 275.00 | 20,900.00 |
| 0021 | 0448200000-E | 310 | 15" RC PIPE CULVERTS, CLASS IV | 3,616 LF | 160.00 | 578,560.00 |
| 0022 | 0448300000-E | 310 | 18" RC PIPE CULVERTS, CLASS IV | 1,112 LF | 185.00 | 205,720.00 |

| Line # | ItemNumber | Sec # | Description | Quantity Unit | Unit Bid Price | Amount Bid |
|--------|--------------|-------|---|---------------|----------------|------------|
| 0023 | 0448400000-E | 310 | 24" RC PIPE CULVERTS, CLASS IV | 204 LF | 235.00 | 47,940.00 |
| 0024 | 0449000000-E | 310 | *** RC PIPE CULVERTS, CLASS V (15") | 104 LF | 170.00 | 17,680.00 |
| 0025 | 0449000000-E | 310 | *** RC PIPE CULVERTS, CLASS V (30") | 40 LF | 350.00 | 14,000.00 |
| 0026 | 0588000000-E | 310 | 18" CS PIPE CULVERTS, 0.064" THICK | 48 LF | 115.00 | 5,520.00 |
| 0027 | 0594000000-E | 310 | 24" CS PIPE CULVERTS, 0.064" THICK | 44 LF | 135.00 | 5,940.00 |
| 0028 | 0636000000-E | 310 | *** CS PIPE ELBOWS, ***** THICK (18", 0.064") | 2 EA | 750.00 | 1,500.00 |
| 0029 | 0973100000-E | 330 | *** WELDED STEEL PIPE, ***** THICK, GRADE B IN SOIL (18", 0.250") | 68 LF | 800.00 | 54,400.00 |
| 0030 | 0973300000-E | 330 | *** WELDED STEEL PIPE, ***** THICK, GRADE B NOT IN SOIL (18", 0.250") | 68 LF | 900.00 | 61,200.00 |
| 0031 | 0995000000-E | 340 | PIPE REMOVAL | 3,444 LF | 20.00 | 68,880.00 |
| 0032 | 1099500000-E | 505 | SHALLOW UNDERCUT | 350 CY | 25.00 | 8,750.00 |
| 0033 | 1099700000-E | 505 | CLASS IV SUBGRADE STABILIZATION | 800 TON | 40.00 | 32,000.00 |
| 0034 | 1112000000-E | 505 | GEOTEXTILE FOR SUBGRADE STABILIZATION | 1,200 SY | 10.00 | 12,000.00 |
| 0035 | 1121000000-E | 520 | AGGREGATE BASE COURSE | 140 TON | 75.00 | 10,500.00 |
| 0036 | 1220000000-E | 545 | INCIDENTAL STONE BASE | 500 TON | 75.00 | 37,500.00 |
| 0037 | 1297000000-E | 607 | MILLING ASPHALT PAVEMENT, ***** DEPTH (1-1/2") | 15,000 SY | 4.00 | 60,000.00 |
| 0038 | 1308000000-E | 607 | MILLING ASPHALT PAVEMENT, ***** TO ***** (0" TO 3") | 7,500 SY | 7.60 | 57,000.00 |
| 0039 | 1330000000-E | 607 | INCIDENTAL MILLING | 7,500 SY | 8.35 | 62,625.00 |
| 0040 | 1491000000-E | 610 | ASPHALT CONC BASE COURSE, TYPE B25.0C | 7,300 TON | 99.00 | 722,700.00 |
| 0041 | 1503000000-E | 610 | ASPHALT CONC INTERMEDIATE COURSE, TYPE I19.0C | 6,600 TON | 97.00 | 640,200.00 |
| 0042 | 1523000000-E | 610 | ASPHALT CONC SURFACE COURSE, TYPE S9.5C | 7,700 TON | 90.00 | 693,000.00 |
| 0043 | 1575000000-E | 620 | ASPHALT BINDER FOR PLANT MIX | 1,100 TON | 695.00 | 764,500.00 |

| Line # | ItemNumber | Sec # | Description | Quantity Unit | Unit Bid Price | Amount Bid |
|--------|--------------|-------|--|---------------|----------------|------------|
| 0044 | 1693000000-E | 654 | ASPHALT PLANT MIX, PAVEMENT REPAIR | 700 TON | 300.00 | 210,000.00 |
| 0045 | 2000000000-N | 806 | RIGHT-OF-WAY MARKERS | 75 EA | 260.00 | 19,500.00 |
| 0046 | 2022000000-E | 815 | SUBDRAIN EXCAVATION | 45 CY | 25.00 | 1,125.00 |
| 0047 | 2026000000-E | 815 | GEOTEXTILE FOR SUBSURFACE DRAINS | 200 SY | 4.00 | 800.00 |
| 0048 | 2036000000-E | 815 | SUBDRAIN COARSE AGGREGATE | 34 CY | 125.00 | 4,250.00 |
| 0049 | 2044000000-E | 815 | 6" PERFORATED SUBDRAIN PIPE | 200 LF | 20.00 | 4,000.00 |
| 0050 | 2070000000-N | 815 | SUBDRAIN PIPE OUTLET | 1 EA | 300.00 | 300.00 |
| 0051 | 2077000000-E | 815 | 6" OUTLET PIPE | 6 LF | 75.00 | 450.00 |
| 0052 | 2253000000-E | 840 | PIPE COLLARS | 0.5 CY | 5,500.00 | 2,750.00 |
| 0053 | 2286000000-N | 840 | MASONRY DRAINAGE STRUCTURES | 99 EA | 5,000.00 | 495,000.00 |
| 0054 | 2308000000-E | 840 | MASONRY DRAINAGE STRUCTURES | 62 LF | 1,200.00 | 74,400.00 |
| 0055 | 2364000000-N | 840 | FRAME WITH TWO GRATES, STD 840.16 | 9 EA | 1,500.00 | 13,500.00 |
| 0056 | 2366000000-N | 840 | FRAME WITH TWO GRATES, STD 840.24 | 4 EA | 1,500.00 | 6,000.00 |
| 0057 | 2367000000-N | 840 | FRAME WITH TWO GRATES, STD 840.29 | 8 EA | 1,500.00 | 12,000.00 |
| 0058 | 2374000000-N | 840 | FRAME WITH GRATE & HOOD, STD 840.03, TYPE ** (E) | 12 EA | 1,500.00 | 18,000.00 |
| 0059 | 2374000000-N | 840 | FRAME WITH GRATE & HOOD, STD 840.03, TYPE ** (F) | 32 EA | 1,500.00 | 48,000.00 |
| 0060 | 2374000000-N | 840 | FRAME WITH GRATE & HOOD, STD 840.03, TYPE ** (G) | 29 EA | 1,500.00 | 43,500.00 |
| 0061 | 2396000000-N | 840 | FRAME WITH COVER, STD 840.54 | 5 EA | 1,500.00 | 7,500.00 |
| 0062 | 2440000000-N | 852 | CONCRETE TRANSITIONAL SECTION FOR CATCH BASIN | 1 EA | 2,500.00 | 2,500.00 |
| 0063 | 2535000000-E | 846 | *** X *** CONCRETE CURB (8" X 18") | 900 LF | 35.00 | 31,500.00 |
| 0064 | 2542000000-E | 846 | 1'-6" CONCRETE CURB & GUTTER | 2,250 LF | 27.00 | 60,750.00 |

| Line # | ItemNumber | Sec # | Description | Quantity Unit | Unit Bid Price | Amount Bid |
|--------|--------------|-------|--|---------------|----------------|------------|
| 0065 | 2549000000-E | 846 | 2'-6" CONCRETE CURB & GUTTER | 8,100 LF | 29.00 | 234,900.00 |
| 0066 | 2570000000-N | SP | MODIFIED CONCRETE FLUME | 2 EA | 3,800.00 | 7,600.00 |
| 0067 | 2580000000-E | 846 | CONCRETE VALLEY GUTTER | 1,000 LF | 28.00 | 28,000.00 |
| 0068 | 2591000000-E | 848 | 4" CONCRETE SIDEWALK | 2,950 SY | 58.00 | 171,100.00 |
| 0069 | 2605000000-N | 848 | CONCRETE CURB RAMPS | 32 EA | 2,290.00 | 73,280.00 |
| 0070 | 2612000000-E | 848 | 6" CONCRETE DRIVEWAY | 500 SY | 93.00 | 46,500.00 |
| 0071 | 2619000000-E | 850 | 4" CONCRETE PAVED DITCH | 11 SY | 200.00 | 2,200.00 |
| 0072 | 2655000000-E | 852 | 5" MONOLITHIC CONCRETE ISLANDS (KEYED IN) | 1,100 SY | 110.00 | 121,000.00 |
| 0073 | 2800000000-N | 858 | ADJUSTMENT OF CATCH BASINS | 1 EA | 2,500.00 | 2,500.00 |
| 0074 | 3536000000-E | 866 | CHAIN LINK FENCE, 48" FABRIC | 220 LF | 20.00 | 4,400.00 |
| 0075 | 3542000000-E | 866 | METAL LINE POSTS FOR 48" CHAIN LINK FENCE | 19 EA | 150.00 | 2,850.00 |
| 0076 | 3548000000-E | 866 | METAL TERMINAL POSTS FOR 48" CHAIN LINK FENCE | 2 EA | 250.00 | 500.00 |
| 0077 | 3628000000-E | 876 | RIP RAP, CLASS I | 380 TON | 120.00 | 45,600.00 |
| 0078 | 3649000000-E | 876 | RIP RAP, CLASS B | 4 TON | 1,000.00 | 4,000.00 |
| 0079 | 3656000000-E | 876 | GEOTEXTILE FOR DRAINAGE | 1,129 SY | 4.00 | 4,516.00 |
| 0080 | 4072000000-E | 903 | SUPPORTS, 3-LB STEEL U-CHANNEL | 750 LF | 9.99 | 7,492.50 |
| 0081 | 4102000000-N | 904 | SIGN ERECTION, TYPE E | 27 EA | 65.00 | 1,755.00 |
| 0082 | 4108000000-N | 904 | SIGN ERECTION, TYPE F | 4 EA | 75.00 | 300.00 |
| 0083 | 4116100000-N | 904 | SIGN ERECTION, RELOCATE TYPE **** (GROUND MOUNTED) (E) | 1 EA | 150.00 | 150.00 |
| 0084 | 4155000000-N | 907 | DISPOSAL OF SIGN SYSTEM, U-CHANNEL | 37 EA | 1.00 | 37.00 |
| 0085 | 4400000000-E | 1110 | WORK ZONE SIGNS (STATIONARY) | 264 SF | 7.75 | 2,046.00 |
| 0086 | 4405000000-E | 1110 | WORK ZONE SIGNS (PORTABLE) | 242 SF | 8.65 | 2,093.30 |

| Line # | ItemNumber | Sec # | Description | Quantity Unit | Unit Bid Price | Amount Bid |
|--------|-------------|-------|---|---------------|----------------|--------------|
| 0087 | 441000000-E | 1110 | WORK ZONE SIGNS (BARRICADE MOUNTED) | 10 SF | 8.85 | 88.50 |
| 0088 | 441500000-N | 1115 | FLASHING ARROW BOARD | 4 EA | 14,000.00 | 56,000.00 |
| 0089 | 442000000-N | 1120 | PORTABLE CHANGEABLE MESSAGE SIGN | 2 EA | 9,800.00 | 19,600.00 |
| 0090 | 443000000-N | 1130 | DRUMS | 300 EA | 100.00 | 30,000.00 |
| 0091 | 443500000-N | 1135 | CONES | 100 EA | 50.00 | 5,000.00 |
| 0092 | 444500000-E | 1145 | BARRICADES (TYPE III) | 64 LF | 25.00 | 1,600.00 |
| 0093 | 444700000-E | SP | PEDESTRIAN CHANNELIZING DEVICES | 30 LF | 68.00 | 2,040.00 |
| 0094 | 445500000-N | 1150 | FLAGGER | 60 DAY | 750.00 | 45,000.00 |
| 0095 | 448000000-N | 1165 | TMA | 2 EA | 20,000.00 | 40,000.00 |
| 0096 | 451600000-N | 1180 | SKINNY DRUM | 100 EA | 100.00 | 10,000.00 |
| 0097 | 460000000-N | SP | GENERIC TRAFFIC CONTROL ITEM AUDIBLE WARNING DEVICE | 2 EA | 165.00 | 330.00 |
| 0098 | 468500000-E | 1205 | THERMOPLASTIC PAVEMENT MARKING LINES (4", 90 MILS) | 18,828 LF | 0.70 | 13,179.60 |
| 0099 | 469500000-E | 1205 | THERMOPLASTIC PAVEMENT MARKING LINES (8", 90 MILS) | 4,130 LF | 2.75 | 11,357.50 |
| 0100 | 470900000-E | 1205 | THERMOPLASTIC PAVEMENT MARKING LINES (24", 90 MILS) | 700 LF | 10.00 | 7,000.00 |
| 0101 | 472500000-E | 1205 | THERMOPLASTIC PAVEMENT MARKING SYMBOL (90 MILS) | 82 EA | 75.00 | 6,150.00 |
| 0102 | 481000000-E | 1205 | PAINT PAVEMENT MARKING LINES (4") | 26,231 LF | 0.25 | 6,557.75 |
| 0103 | 482000000-E | 1205 | PAINT PAVEMENT MARKING LINES (8") | 4,276 LF | 0.75 | 3,207.00 |
| 0104 | 483500000-E | 1205 | PAINT PAVEMENT MARKING LINES (24") | 950 LF | 4.00 | 3,800.00 |
| 0105 | 484000000-N | 1205 | PAINT PAVEMENT MARKING CHARACTER | 8 EA | 25.00 | 200.00 |
| 0106 | 484500000-N | 1205 | PAINT PAVEMENT MARKING SYMBOL | 115 EA | 25.00 | 2,875.00 |
| 0107 | 532560000-E | 1510 | 6" WATER LINE | 5,507 LF | 200.00 | 1,101,400.00 |
| 0108 | 532580000-E | 1510 | 8" WATER LINE | 80 LF | 400.00 | 32,000.00 |
| 0109 | 532660000-E | 1510 | 16" WATER LINE | 483 LF | 550.00 | 265,650.00 |

| Line # | ItemNumber | Sec # | Description | Quantity Unit | Unit Bid Price | Amount Bid |
|--------|--------------|-------|---------------------------------------|---------------|----------------|------------|
| 0110 | 5329000000-E | 1510 | DUCTILE IRON WATER PIPE FITTINGS | 11,690 LB | 20.00 | 233,800.00 |
| 0111 | 5540000000-E | 1515 | 6" VALVE | 30 EA | 5,000.00 | 150,000.00 |
| 0112 | 5546000000-E | 1515 | 8" VALVE | 1 EA | 5,500.00 | 5,500.00 |
| 0113 | 5648000000-N | 1515 | RELOCATE WATER METER | 23 EA | 3,500.00 | 80,500.00 |
| 0114 | 5649000000-N | 1515 | RECONNECT WATER METER | 1 EA | 2,000.00 | 2,000.00 |
| 0115 | 5666000000-N | 1515 | FIRE HYDRANT | 4 EA | 10,000.00 | 40,000.00 |
| 0116 | 5673000000-E | 1515 | FIRE HYDRANT LEG | 104 LF | 175.00 | 18,200.00 |
| 0117 | 5686500000-E | 1515 | WATER SERVICE LINE | 499 LF | 150.00 | 74,850.00 |
| 0118 | 5691300000-E | 1520 | 8" SANITARY GRAVITY SEWER | 824 LF | 275.00 | 226,600.00 |
| 0119 | 5768000000-N | 1520 | SANITARY SEWER CLEAN-OUT | 11 EA | 5,000.00 | 55,000.00 |
| 0120 | 5768500000-E | 1520 | SEWER SERVICE LINE | 200 LF | 350.00 | 70,000.00 |
| 0121 | 5775000000-E | 1525 | 4' DIA UTILITY MANHOLE | 7 EA | 4,000.00 | 28,000.00 |
| 0122 | 5781000000-E | 1525 | UTILITY MANHOLE WALL 4' DIA | 15 LF | 750.00 | 11,250.00 |
| 0123 | 5800000000-E | 1530 | ABANDON 6" UTILITY PIPE | 5,311 LF | 20.00 | 106,220.00 |
| 0124 | 5801000000-E | 1530 | ABANDON 8" UTILITY PIPE | 1,607 LF | 20.00 | 32,140.00 |
| 0125 | 5816000000-N | 1530 | ABANDON UTILITY MANHOLE | 6 EA | 5,000.00 | 30,000.00 |
| 0126 | 5828000000-N | 1530 | REMOVE UTILITY MANHOLE | 2 EA | 7,500.00 | 15,000.00 |
| 0127 | 5835700000-E | 1540 | 16" ENCASEMENT PIPE | 100 LF | 1,000.00 | 100,000.00 |
| 0128 | 6000000000-E | 1605 | TEMPORARY SILT FENCE | 12,495 LF | 3.05 | 38,109.75 |
| 0129 | 6006000000-E | 1610 | STONE FOR EROSION CONTROL, CLASS A | 645 TON | 50.00 | 32,250.00 |
| 0130 | 6009000000-E | 1610 | STONE FOR EROSION CONTROL, CLASS B | 425 TON | 50.00 | 21,250.00 |
| 0131 | 6012000000-E | 1610 | SEDIMENT CONTROL STONE | 625 TON | 50.00 | 31,250.00 |
| 0132 | 6015000000-E | 1615 | TEMPORARY MULCHING | 17 ACR | 1,350.00 | 22,950.00 |

| Line # | ItemNumber | Sec # | Description | Quantity Unit | Unit Bid Price | Amount Bid |
|--------|--------------|-------|--|---------------|----------------|------------|
| 0133 | 6018000000-E | 1620 | SEED FOR TEMPORARY SEEDING | 1,100 LB | 3.00 | 3,300.00 |
| 0134 | 6021000000-E | 1620 | FERTILIZER FOR TEMPORARY SEEDING | 5.5 TON | 1,250.00 | 6,875.00 |
| 0135 | 6024000000-E | 1622 | TEMPORARY SLOPE DRAINS | 200 LF | 10.00 | 2,000.00 |
| 0136 | 6029000000-E | SP | SAFETY FENCE | 560 LF | 2.25 | 1,260.00 |
| 0137 | 6030000000-E | 1630 | SILT EXCAVATION | 1,100 CY | 15.00 | 16,500.00 |
| 0138 | 6036000000-E | 1631 | MATTING FOR EROSION CONTROL | 7,585 SY | 1.60 | 12,136.00 |
| 0139 | 6042000000-E | 1632 | 1/4" HARDWARE CLOTH | 360 LF | 6.00 | 2,160.00 |
| 0140 | 6071002000-E | 1642 | FLOCCULANT | 50 LB | 16.00 | 800.00 |
| 0141 | 6071030000-E | 1640 | COIR FIBER BAFFLE | 25 LF | 8.00 | 200.00 |
| 0142 | 6084000000-E | 1660 | SEEDING & MULCHING | 15 ACR | 2,450.00 | 36,750.00 |
| 0143 | 6087000000-E | 1660 | MOWING | 12 ACR | 225.00 | 2,700.00 |
| 0144 | 6090000000-E | 1661 | SEED FOR REPAIR SEEDING | 200 LB | 8.00 | 1,600.00 |
| 0145 | 6093000000-E | 1661 | FERTILIZER FOR REPAIR SEEDING | 0.5 TON | 2,100.00 | 1,050.00 |
| 0146 | 6096000000-E | 1662 | SEED FOR SUPPLEMENTAL SEEDING | 375 LB | 7.00 | 2,625.00 |
| 0147 | 6108000000-E | 1665 | FERTILIZER TOPDRESSING | 11.25 TON | 1,400.00 | 15,750.00 |
| 0148 | 6114500000-N | 1667 | SPECIALIZED HAND MOWING | 10 MHR | 95.00 | 950.00 |
| 0149 | 6114800000-N | SP | MANUAL LITTER REMOVAL | 7 MHR | 75.00 | 525.00 |
| 0150 | 6114900000-E | SP | LITTER DISPOSAL | 1 TON | 500.00 | 500.00 |
| 0151 | 6117000000-N | 1675 | RESPONSE FOR EROSION CONTROL | 25 EA | 350.00 | 8,750.00 |
| 0152 | 6117500000-N | SP | CONCRETE WASHOUT STRUCTURE | 6 EA | 2,000.00 | 12,000.00 |
| 0153 | 6132000000-N | SP | GENERIC EROSION CONTROL ITEM FABRIC INSERT INLET PROTECTION CLEANOUT | 549 EA | 140.00 | 76,860.00 |
| 0154 | 6132000000-N | SP | GENERIC EROSION CONTROL ITEM FABRIC INSERT INLET PROTECTION, TYPE 1 | 183 EA | 140.00 | 25,620.00 |

| Line # | ItemNumber | Sec # | Description | Quantity Unit | Unit Bid Price | Amount Bid |
|--------|--------------|-------|---|---------------|----------------|------------|
| 0155 | 7048500000-E | 1705 | PEDESTRIAN SIGNAL HEAD (16", 1 SECTION W/COUNTDOWN) | 22 EA | 1,500.00 | 33,000.00 |
| 0156 | 7060000000-E | 1705 | SIGNAL CABLE | 13,525 LF | 5.00 | 67,625.00 |
| 0157 | 7120000000-E | 1705 | VEHICLE SIGNAL HEAD (12", 3 SECTION) | 52 EA | 1,300.00 | 67,600.00 |
| 0158 | 7132000000-E | 1705 | VEHICLE SIGNAL HEAD (12", 4 SECTION) | 12 EA | 1,500.00 | 18,000.00 |
| 0159 | 7204000000-N | 1705 | LOUVER | 2 EA | 250.00 | 500.00 |
| 0160 | 7264000000-E | 1710 | MESSENGER CABLE (3/8") | 1,450 LF | 10.00 | 14,500.00 |
| 0161 | 7300000000-E | 1715 | UNPAVED TRENCHING (***** (2, 2") | 1,800 LF | 20.00 | 36,000.00 |
| 0162 | 7301000000-E | 1715 | DIRECTIONAL DRILL (***** (2, 2") | 650 LF | 50.00 | 32,500.00 |
| 0163 | 7324000000-N | 1716 | JUNCTION BOX (STANDARD SIZE) | 33 EA | 750.00 | 24,750.00 |
| 0164 | 7360000000-N | 1720 | WOOD POLE | 13 EA | 1,800.00 | 23,400.00 |
| 0165 | 7372000000-N | 1721 | GUY ASSEMBLY | 22 EA | 1,500.00 | 33,000.00 |
| 0166 | 7408000000-E | 1722 | 1" RISER WITH WEATHERHEAD | 3 EA | 600.00 | 1,800.00 |
| 0167 | 7420000000-E | 1722 | 2" RISER WITH WEATHERHEAD | 7 EA | 1,100.00 | 7,700.00 |
| 0168 | 7444000000-E | 1725 | INDUCTIVE LOOP SAWCUT | 2,550 LF | 15.00 | 38,250.00 |
| 0169 | 7456100000-E | 1726 | LEAD-IN CABLE (14-2) | 5,950 LF | 4.00 | 23,800.00 |
| 0170 | 7481000000-N | SP | SITE SURVEY | 4 EA | 1,000.00 | 4,000.00 |
| 0171 | 7481240000-N | SP | CAMERA WITHOUT INTERNAL LOOP EMULATOR PROCESSING UNIT | 12 EA | 3,500.00 | 42,000.00 |
| 0172 | 7481260000-N | SP | EXTERNAL LOOP EMULATOR PROCESSING UNIT | 4 EA | 5,200.00 | 20,800.00 |
| 0173 | 7575142010-N | 1736 | 900MHZ SERIAL/ETHERNET SPREAD SPECTRUM RADIO | 6 EA | 6,000.00 | 36,000.00 |
| 0174 | 7575142060-N | 1737 | MODIFY RADIO INSTALLATION | 5 EA | 1,400.00 | 7,000.00 |
| 0175 | 7588000000-N | SP | METAL POLE WITH SINGLE MAST ARM | 1 EA | 30,000.00 | 30,000.00 |
| 0176 | 7590000000-N | SP | METAL POLE WITH DUAL MAST ARM | 5 EA | 50,000.00 | 250,000.00 |
| 0177 | 7613000000-N | SP | SOIL TEST | 6 EA | 2,500.00 | 15,000.00 |

| Line # | ItemNumber | Sec # | Description | Quantity Unit | Unit Bid Price | Amount Bid |
|--------|--------------|-------|--|---------------|----------------|------------|
| 0178 | 7614100000-E | SP | DRILLED PIER FOUNDATION | 54 CY | 2,000.00 | 108,000.00 |
| 0179 | 7631000000-N | SP | MAST ARM WITH METAL POLE DESIGN | 6 EA | 200.00 | 1,200.00 |
| 0180 | 7636000000-N | 1745 | SIGN FOR SIGNALS | 3 EA | 500.00 | 1,500.00 |
| 0181 | 7642100000-N | 1743 | TYPE I POST WITH FOUNDATION | 8 EA | 2,200.00 | 17,600.00 |
| 0182 | 7642200000-N | 1743 | TYPE II PEDESTAL WITH FOUNDATION | 9 EA | 3,000.00 | 27,000.00 |
| 0183 | 7642300000-N | 1743 | TYPE III PEDESTAL WITH FOUNDATION | 1 EA | 5,600.00 | 5,600.00 |
| 0184 | 7684000000-N | 1750 | SIGNAL CABINET FOUNDATION | 3 EA | 2,500.00 | 7,500.00 |
| 0185 | 7696000000-N | 1751 | CONTROLLERS WITH CABINET (***** (2070LX, 332) | 1 EA | 27,600.00 | 27,600.00 |
| 0186 | 7744000000-N | 1751 | DETECTOR CARD (TYPE 170) | 19 EA | 335.00 | 6,365.00 |
| 0187 | 7960000000-N | SP | METAL POLE FOUNDATION REMOVAL | 1 EA | 2,500.00 | 2,500.00 |
| 0188 | 7972000000-N | SP | METAL POLE REMOVAL | 1 EA | 700.00 | 700.00 |
| 0189 | 7980000000-N | SP | GENERIC SIGNAL ITEM 2070LX CONTROLLER | 5 EA | 6,600.00 | 33,000.00 |
| 0190 | 7980000000-N | SP | GENERIC SIGNAL ITEM CABINET WITHOUT CONTROLLER (332) | 2 EA | 22,000.00 | 44,000.00 |
| 0191 | 7980000000-N | SP | GENERIC SIGNAL ITEM ETHERNET EDGE SWITCH | 6 EA | 2,100.00 | 12,600.00 |
| 0192 | 7980000000-N | SP | GENERIC SIGNAL ITEM LUMINAIRE ARM FOR TEMPORARY VIDEO SYSTEM | 13 EA | 1,000.00 | 13,000.00 |
| 0193 | 7980000000-N | SP | GENERIC SIGNAL ITEM PROTECTIVE COATING FOR DUAL MAST ARM POLE (BLACK) | 5 EA | 7,200.00 | 36,000.00 |
| 0194 | 7980000000-N | SP | GENERIC SIGNAL ITEM PROTECTIVE COATING FOR SINGLE MAST ARM POLE (BLACK) | 1 EA | 2,900.00 | 2,900.00 |
| 0195 | 7980000000-N | SP | GENERIC SIGNAL ITEM PROTECTIVE COATING FOR TYPE I PUSHBUTTON POST (BLACK) | 8 EA | 100.00 | 800.00 |
| 0196 | 7980000000-N | SP | GENERIC SIGNAL ITEM PROTECTIVE COATING FOR TYPE II SIGNAL PEDESTAL (BLACK) | 9 EA | 150.00 | 1,350.00 |

Contract Item Sheets For C204941

| Line # | ItemNumber | Sec # | Description | Quantity Unit | Unit Bid Price | Amount Bid |
|--------|--------------|-------|---|---------------|----------------|------------|
| 0197 | 7980000000-N | SP | GENERIC SIGNAL ITEM PROTECTIVE COATING FOR TYPE III SIGNAL PEDESTAL (BLACK) | 1 EA | 200.00 | 200.00 |

TOTAL AMOUNT OF BID FOR ENTIRE PROJECT \$13,458,673.90

Fuel Usage Factor Adjustment Form

| | |
|----------------------|------------------------------------|
| Contract Number | C204941 |
| County | Davidson |
| Contractor Name | Kemp Sigmon Construction Co., Inc. |
| HiCAMS Vendor Number | 18313 |

Select a Fuel Usage Factor for each of the Asphalt Material Descriptions to be used on the project. Within the Selected Fuel Usage Factor column, choose either 2.90 or 0.90 Gallons per Ton for the corresponding asphalt material description.

The Selected Fuel Usage Factor chosen will be used for the entire contract duration.

| Description | Unit | Selected Fuel Usage Factor | |
|---|---------|-------------------------------------|--------------------------|
| | | 0.90 | 2.90 |
| Asphalt Concrete Base Course, Type B25.0C | Gal/Ton | <input checked="" type="checkbox"/> | <input type="checkbox"/> |
| Asphalt Concrete Intermediate Course, Type I19.0C | Gal/Ton | <input checked="" type="checkbox"/> | <input type="checkbox"/> |
| Asphalt Concrete Surface Course, Type SA-1 | Gal/Ton | <input checked="" type="checkbox"/> | <input type="checkbox"/> |
| Asphalt Concrete Surface Course, Type SA-1 (Leveling Course) | Gal/Ton | <input checked="" type="checkbox"/> | <input type="checkbox"/> |
| Asphalt Concrete Surface Course, Type S4.75 | Gal/Ton | <input checked="" type="checkbox"/> | <input type="checkbox"/> |
| Asphalt Concrete Surface Course, Type S4.75 (Leveling Course) | Gal/Ton | <input checked="" type="checkbox"/> | <input type="checkbox"/> |
| Asphalt Concrete Surface Course, Type S9.5B | Gal/Ton | <input checked="" type="checkbox"/> | <input type="checkbox"/> |
| Asphalt Concrete Surface Course, Type S9.5B (Leveling Course) | Gal/Ton | <input checked="" type="checkbox"/> | <input type="checkbox"/> |
| Asphalt Concrete Surface Course, Type S9.5C | Gal/Ton | <input checked="" type="checkbox"/> | <input type="checkbox"/> |
| Asphalt Concrete Surface Course, Type S9.5C (Leveling Course) | Gal/Ton | <input checked="" type="checkbox"/> | <input type="checkbox"/> |
| Asphalt Concrete Surface Course, Type S9.5D | Gal/Ton | <input checked="" type="checkbox"/> | <input type="checkbox"/> |
| Asphalt Concrete Surface Course, Type S9.5D (Leveling Course) | Gal/Ton | <input checked="" type="checkbox"/> | <input type="checkbox"/> |
| Open-Graded Asphalt Friction Course | Gal/Ton | <input checked="" type="checkbox"/> | <input type="checkbox"/> |
| Permeable Asphalt Drainage Course, Type _____ | Gal/Ton | <input checked="" type="checkbox"/> | <input type="checkbox"/> |
| Sand Asphalt Surface Course, Type _____ | Gal/Ton | <input checked="" type="checkbox"/> | <input type="checkbox"/> |

If the Contractor does not mark either Fuel Usage Factor or marks both Fuel Usage Factors for an asphalt item description, the 2.90 Fuel Usage Factor shall be used for that asphalt line item.

Contract No. C204941
County Davidson

Rev. 1-16-18

**EXECUTION OF CONTRACT
NON-COLLUSION, DEBARMENT AND GIFT BAN CERTIFICATION**

CORPORATION

The Contractor declares (or certifies, verifies, or states) under penalty of perjury under the laws of the United States that neither he, nor any official, agent or employee has entered into any agreement, participated in any collusion, or otherwise taken any action which is in restraint of free competitive bidding in connection with this Contract, that the Contractor has not been convicted of violating *N.C.G.S. § 133-24* within the last three years, and that the Contractor intends to do the work with its own bona fide employees or subcontractors and did not bid for the benefit of another contractor.

By submitting this Execution of Contract, Non-Collusion and Debarment Certification, the Contractor is certifying his status under penalty of perjury under the laws of the United States in accordance with the Debarment Certification attached, provided that the Debarment Certification also includes any required statements concerning exceptions that are applicable.

N.C.G.S. § 133-32 and Executive Order 24 prohibit the offer to, or acceptance by, any State Employee of any gift from anyone with a contract with the State, or from any person seeking to do business with the State. By execution of any response in this procurement, you attest, for your entire organization and its employees or agents, that you are not aware that any such gift has been offered, accepted, or promised by any employees of your organization.

SIGNATURE OF CONTRACTOR

Kemp Sigmon Construction Co., Inc.

Full name of Corporation

PO Box 1210, Claremont, NC 28610

Address as Prequalified

Attest

Secretary/Assistant Secretary
Select appropriate title

By

President/Vice President/Assistant Vice President
Select appropriate title

Kelsey Sigmon

Print or type Signer's name

Tyler Sigmon

Print or type Signer's name

CORPORATE SEAL

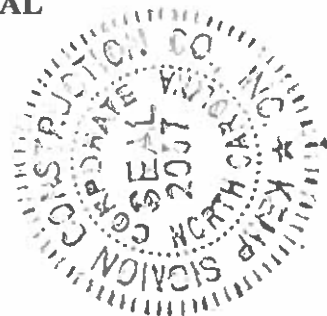

DEBARMENT CERTIFICATION

Conditions for certification:

1. The prequalified bidder shall provide immediate written notice to the Department if at any time the bidder learns that his certification was erroneous when he submitted his debarment certification or explanation filed with the Department, or has become erroneous because of changed circumstances.
2. The terms *covered transaction, debarred, suspended, ineligible, lower tier covered transaction, participant, person, primary covered transaction, principal, proposal, and voluntarily excluded*, as used in this provision, have the meanings set out in the Definitions and Coverage sections of the rules implementing Executive Order 12549. A copy of the Federal Rules requiring this certification and detailing the definitions and coverages may be obtained from the Contract Officer of the Department.
3. The prequalified bidder agrees by submitting this form, that he will not knowingly enter into any lower tier covered transaction with a person who is debarred, suspended, declared ineligible, or voluntarily excluded from participation in NCDOT contracts, unless authorized by the Department.
4. For Federal Aid projects, the prequalified bidder further agrees that by submitting this form he will include the Federal-Aid Provision titled *Required Contract Provisions Federal-Aid Construction Contract (Form FHWA PR 1273)* provided by the Department, without subsequent modification, in all lower tier covered transactions.
5. The prequalified bidder may rely upon a certification of a participant in a lower tier covered transaction that he is not debarred, suspended, ineligible, or voluntarily excluded from the covered transaction, unless he knows that the certification is erroneous. The bidder may decide the method and frequency by which he will determine the eligibility of his subcontractors.
6. Nothing contained in the foregoing shall be construed to require establishment of a system of records in order to render in good faith the certification required by this provision. The knowledge and information of a participant is not required to exceed that which is normally possessed by a prudent person in the ordinary course of business dealings.
7. Except as authorized in paragraph 6 herein, the Department may terminate any contract if the bidder knowingly enters into a lower tier covered transaction with a person who is suspended, debarred, ineligible, or voluntarily excluded from participation in this transaction, in addition to other remedies available by the Federal Government.

DEBARMENT CERTIFICATION

The prequalified bidder certifies to the best of his knowledge and belief, that he and his principals:

- a. Are not presently debarred, suspended, proposed for debarment, declared ineligible, or voluntarily excluded from covered transactions by any Federal department or agency;
- b. Have not within a three-year period preceding this proposal been convicted of or had a civil judgment rendered against them for commission of fraud or a criminal offense in connection with obtaining, attempting to obtain, or performing a public (Federal, State or local) transaction or contract under a public transaction; violation of Federal or State antitrust statutes or commission of embezzlement, theft, forgery, bribery, falsification or destruction of records; making false statements; or receiving stolen property;
- c. Are not presently indicted for or otherwise criminally or civilly charged by a governmental entity (Federal, State or local) with commission of any of the offenses enumerated in paragraph b. of this certification; and
- d. Have not within a three-year period preceding this proposal had one or more public transactions (Federal, State or local) terminated for cause or default.
- e. Will submit a revised Debarment Certification immediately if his status changes and will show in his bid proposal an explanation for the change in status.

If the prequalified bidder cannot certify that he is not debarred, he shall provide an explanation with this submittal. An explanation will not necessarily result in denial of participation in a contract.

Failure to submit a non-collusion and debarment certification will result in the prequalified bidder's bid being considered non-responsive.

Check here if an explanation is attached to this certification.

Contract No. **C204941**

County (ies): **Davidson**

ACCEPTED BY THE
DEPARTMENT OF TRANSPORTATION

Signed by:

Ronald E. Davenport, Jr.

52C46046381F443...

Contract Officer

10/17/2024

Date

Execution of Contract and Bonds
Approved as to Form:

Signed by:

[Signature]

646E313577A7476...

Attorney General

10/17/2024

Date

Bond No. 800178267

Contract No. C204941
County Davidson

Rev 5-17-11

CONTRACT PAYMENT BOND

Date of Payment Bond Execution September 27, 2024
Name of Principal Contractor Kemp Sigmon Construction Co., Inc.
Name of Surety: Atlantic Specialty Insurance Company
Name of Contracting Body: North Carolina Department of Transportation
Raleigh, North Carolina
Amount of Bond: (\$13,458,673.90) Thirteen Million Four Hundred Fifty Eight Thousand Six Hundred Seventy Three Dollars and 90/100
Contract ID No.: C204941
County Name: Davidson

KNOW ALL MEN BY THESE PRESENTS, That we, the PRINCIPAL CONTRACTOR (hereafter, PRINCIPAL) and SURETY above named, are held and firmly bound unto the above named Contracting Body, hereinafter called the Contracting Body, in the penal sum of the amount stated above for the payment of which sum well and truly to be made, we bind ourselves, our heirs, executors, administrators, and successors, jointly and severally, firmly by these presents.

THE CONDITION OF THIS OBLIGATION IS SUCH, that whereas the principal entered into a certain contract with the Contracting Body, numbered as shown above and hereto attached:

NOW THEREFORE, if the principal shall promptly make payment to all persons supplying labor and material in the prosecution of the work provided for in said contract, and any and all duly authorized modifications of said contract that may hereafter be made, notice of which modifications to the surety being hereby waived, then this obligation to be void; otherwise to remain in full force and virtue.

IN WITNESS WHEREOF, the above-bound parties have executed this instrument under their several seals on the date indicated above, the name and corporate seal of each corporate party being hereto affixed and these presents duly signed by its undersigned representative, pursuant to authority of its governing body.

Contract No. C204941
County Davidson

Rev 5-17-11

CONTRACT PAYMENT BOND

Affix Seal of Surety Company

Atlantic Specialty Insurance Company
Print or type Surety Company Name

By Angela Y. Buckner
Print, stamp or type name of Attorney-in-Fact

Angela Y. Buckner
Signature of Attorney-in-Fact

Surety Phone No. 952-852-2431

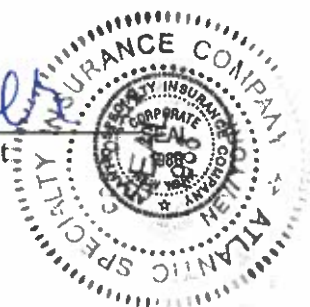

Jenny Snell
Signature of Witness

Jenny Snell
Print or type Signer's name

5605 Carnegie Boulevard, Suite 300
Charlotte, NC 28209
Address of Attorney-in-Fact

Contract No. C204941
County Davidson

Rev 5-17-11

CONTRACT PAYMENT BOND

CORPORATION

SIGNATURE OF CONTRACTOR (Principal)

Kemp Sigmon Construction Co., Inc.
Full name of Corporation

PO Box 1210, Claremont, NC 28610
Address as prequalified

By 
Signature of President, Vice President, Assistant Vice President
Select appropriate title

Tyler Sigmon
Print or type Signer's name

Affix Corporate Seal

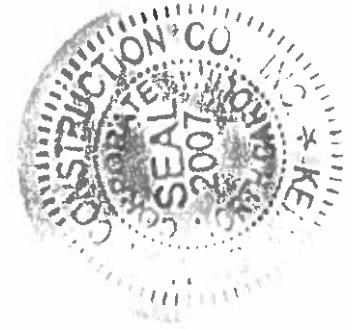

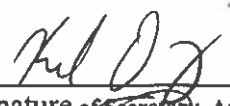
Attest 
Signature of Secretary, Assistant Secretary
Select appropriate title

Kelsey Sigmon
Print or type Signer's name

Contract No. C204941
County Davidson

CONTRACT PERFORMANCE BOND

Date of Performance Bond Execution: September 27, 2024
Name of Principal Contractor: Kemp Sigmon Construction Co., Inc.
Name of Surety: Atlantic Specialty Insurance Company
Name of Contracting Body: North Carolina Department of Transportation
Raleigh, North Carolina
Amount of Bond: (\$13,458,673.90) Thirteen Million Four Hundred Fifty Eight Thousand Six Hundred Seventy Three Dollars and 90/100
Contract ID No.: C204941
County Name: Davidson

KNOW ALL MEN BY THESE PRESENTS, That we, the PRINCIPAL CONTRACTOR (hereafter, PRINCIPAL) and SURETY above named, are held and firmly bound unto the above named Contracting Body, hereinafter called the Contracting Body, in the penal sum of the amount stated above for the payment of which sum well and truly to be made, we bind ourselves, our heirs, executors, administrators, and successors, jointly and severally, firmly by these presents.

THE CONDITION OF THIS OBLIGATION IS SUCH, that whereas the principal entered into a certain contract with the Contracting Body, numbered as shown above and hereto attached:

NOW THEREFORE, if the principal shall well and truly perform and fulfill all the undertakings, covenants, terms, conditions, and agreements of said contract during the original term of said contract and any extensions thereof that may be granted by the Contracting Body, with or without notice to the Surety, and during the life of any guaranty required under the contract, and shall also well and truly perform and fulfill all the undertakings, covenants, terms, conditions, and agreements of any and all duly authorized modifications of said contract that may hereafter be made, notice of which modifications to the surety being hereby waived, then this obligation to be void; otherwise to remain in full force and virtue.

IN WITNESS WHEREOF, the above-bound parties have executed this instrument under their several seals on the date indicated above, the name and corporate seal of each corporate party being hereto affixed and these presents duly signed by its undersigned representative, pursuant to authority of its governing body.

Contract No. C204941
County Davidson

Rev 5-17-11

CONTRACT PERFORMANCE BOND

CORPORATION

SIGNATURE OF CONTRACTOR (Principal)

Kemp Sigmon Construction Co., Inc.
Full name of Corporation

PO Box 1210, Claremont, NC 28610
Address as prequalified

By 
Signature of ~~President~~, Vice President, Assistant Vice President
Select appropriate title

Tyler Sigmon
Print or type Signer's name

Affix Corporate Seal

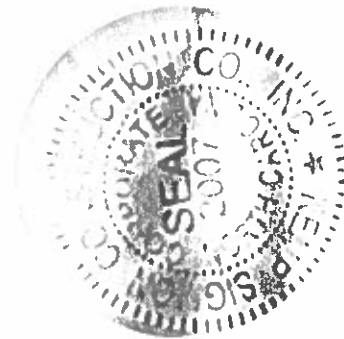

Attest 
Signature of Secretary, Assistant Secretary
Select appropriate title

Kelsey Sigmon
Print or type Signer's name



Power of Attorney

Surety Bond No: 800178267

Principal: Kemp Sigmon Construction Co., Inc.
Obligee: NCDOT, Contract Standards and Development

KNOW ALL MEN BY THESE PRESENTS, that ATLANTIC SPECIALTY INSURANCE COMPANY, a New York corporation with its principal office in Plymouth, Minnesota, does hereby constitute and appoint: Angela Y. Buckner, each individually if there be more than one named, its true and lawful Attorney-in-Fact, to make, execute, seal and deliver, for and on its behalf as surety, any and all bonds, recognizances, contracts of indemnity, and all other writings obligatory in the nature thereof; provided that no bond or undertaking executed under this authority shall exceed in amount the sum of: sixty million dollars (\$60,000,000) and the execution of such bonds, recognizances, contracts of indemnity, and all other writings obligatory in the nature thereof in pursuance of these presents, shall be as binding upon said Company as if they had been fully signed by an authorized officer of the Company and sealed with the Company seal. This Power of Attorney is made and executed by authority of the following resolutions adopted by the Board of Directors of ATLANTIC SPECIALTY INSURANCE COMPANY on the twenty-fifth day of September, 2012:

Resolved: That the President, any Senior Vice President or Vice-President (each an "Authorized Officer") may execute for and in behalf of the Company any and all bonds, recognizances, contracts of indemnity, and all other writings obligatory in the nature thereof, and affix the seal of the Company thereto; and that the Authorized Officer may appoint and authorize an Attorney-in-Fact to execute on behalf of the Company any and all such instruments and to affix the Company seal thereto; and that the Authorized Officer may at any time remove any such Attorney-in-Fact and revoke all power and authority given to any such Attorney-in-Fact.

Resolved: That the Attorney-in-Fact may be given full power and authority to execute for and in the name and on behalf of the Company any and all bonds, recognizances, contracts of indemnity, and all other writings obligatory in the nature thereof, and any such instrument executed by any such Attorney-in-Fact shall be as binding upon the Company as if signed and sealed by an Authorized Officer and, further, the Attorney-in-Fact is hereby authorized to verify any affidavit required to be attached to bonds, recognizances, contracts of indemnity, and all other writings obligatory in the nature thereof.

This power of attorney is signed and sealed by facsimile under the authority of the following Resolution adopted by the Board of Directors of ATLANTIC SPECIALTY INSURANCE COMPANY on the twenty-fifth day of September, 2012:

Resolved: That the signature of an Authorized Officer, the signature of the Secretary or the Assistant Secretary, and the Company seal may be affixed by facsimile to any power of attorney or to any certificate relating thereto appointing an Attorney-in-Fact for purposes only of executing and sealing any bond, undertaking, recognizance or other written obligation in the nature thereof, and any such signature and seal where so used, being hereby adopted by the Company as the original signature of such officer and the original seal of the Company, to be valid and binding upon the Company with the same force and effect as though manually affixed.

IN WITNESS WHEREOF, ATLANTIC SPECIALTY INSURANCE COMPANY has caused these presents to be signed by an Authorized Officer and the seal of the Company to be affixed this fifth day of March, 2020.



By *Paul J. Brehm*
Paul J. Brehm, Senior Vice President

STATE OF MINNESOTA
HENNEPIN COUNTY

On this fifth day of March, 2020, before me personally came Paul J. Brehm, Senior Vice President of ATLANTIC SPECIALTY INSURANCE COMPANY, to me personally known to be the individual and officer described in and who executed the preceding instrument, and he acknowledged the execution of the same, and being by me duly sworn, that he is the said officer of the Company aforesaid, and that the seal affixed to the preceding instrument is the seal of said Company and that the said seal and the signature as such officer was duly affixed and subscribed to the said instrument by the authority and at the direction of the Company.

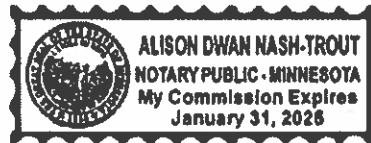

Alison Nash-Trout
Notary Public

I, the undersigned, Assistant Secretary of ATLANTIC SPECIALTY INSURANCE COMPANY, a New York Corporation, do hereby certify that the foregoing power of attorney is in full force and has not been revoked, and the resolutions set forth above are now in force.

Signed and sealed. Dated 27th day of September, 2024.



Christopher V. Jerry
Christopher V. Jerry, Secretary